

P O O L T A K

LEIA

I. Allmän Monteringsmanual

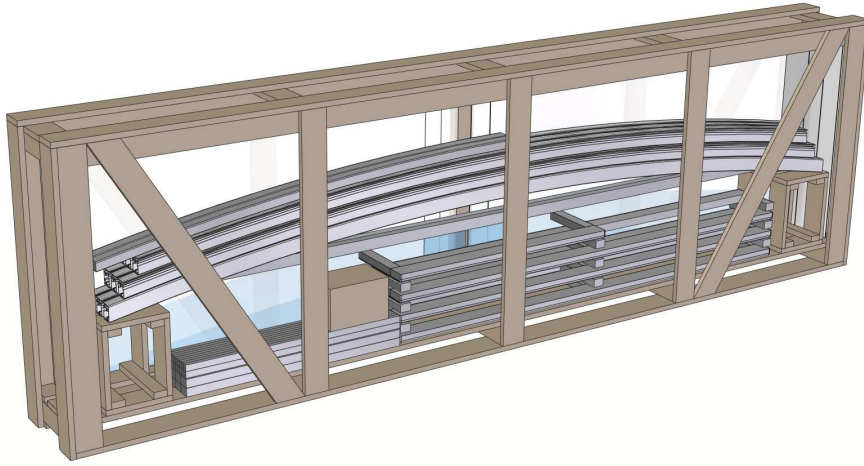

### Skjuddörr på högersidan Sett framifrån största sektionen:

2. Skeninstallation .... 3-4
3. Största sektionen .... 4-11
4. Övriga sektionerna .... 12-18
5. Lister och övriga detaljer .... 19-21
6. Skjuddörr .... 22-27
7. Front och bak gavel .... 28-29
8. Slutmontering .... 30-34

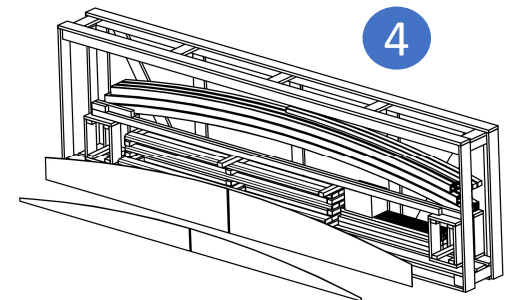
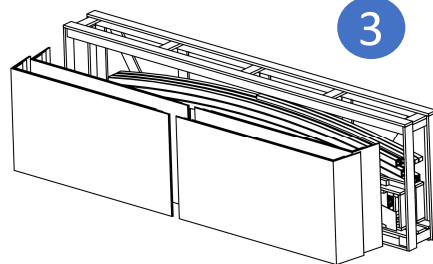
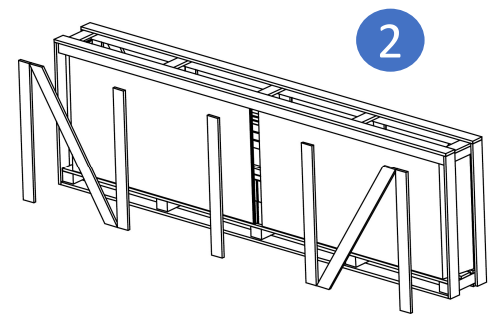
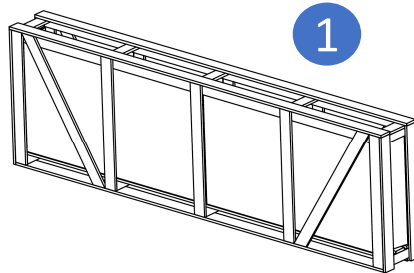

### Skjuddörr på vänstersidan Sett framifrån största sektionen:

2. Skeninstallation .... 35-36
3. Största sektionen .... 36-43
4. Övriga sektionerna .... 44-50
5. Lister och övriga detaljer .... 51-53
6. Skjuddörr .... 54-59
7. Front och bak gavel .... 59-61
8. Slutmontering .... 62-66

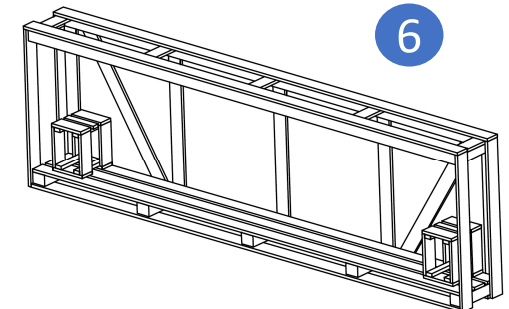
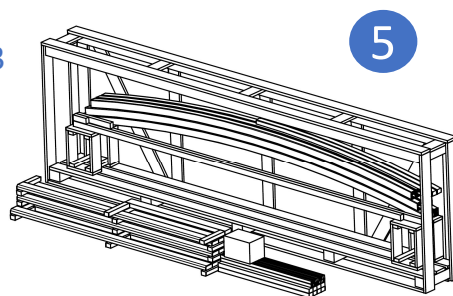

#### OBS!

1. Innan plastpanelerna monteras toges skyddsplasten av.
2. Skruvarna fettas in före montering för att undvika skador (fettet är inte inkluderat). (tex. universalfett)
3. Skjuddörren på högersida instruktioner 3-34. Sett framifrån största sektionen
4. Skjuddörren på vänstersida instruktioner 35-66. Sett framifrån största sektionen



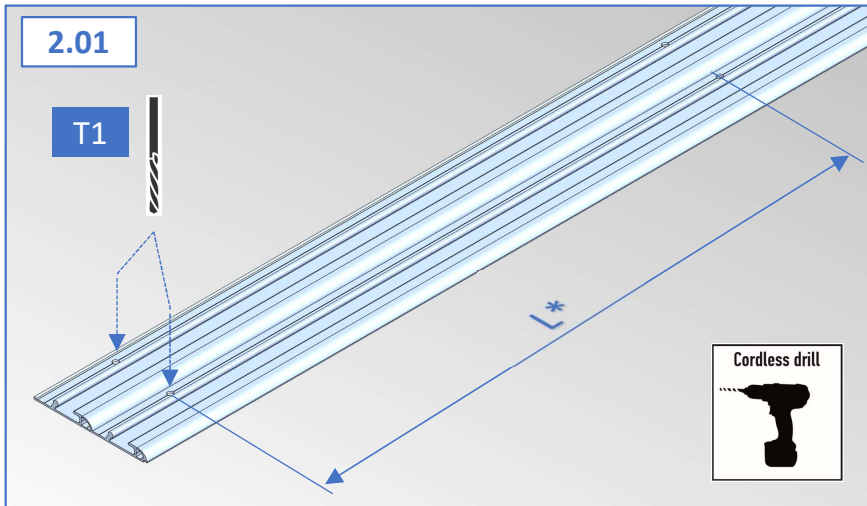

L\* - Borrhålets position  
olika beroende på  
modell!  
(Se sidan 3., Manual II.)

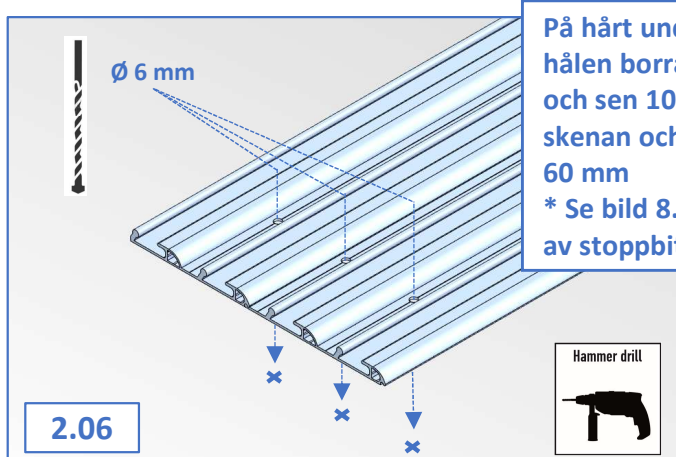
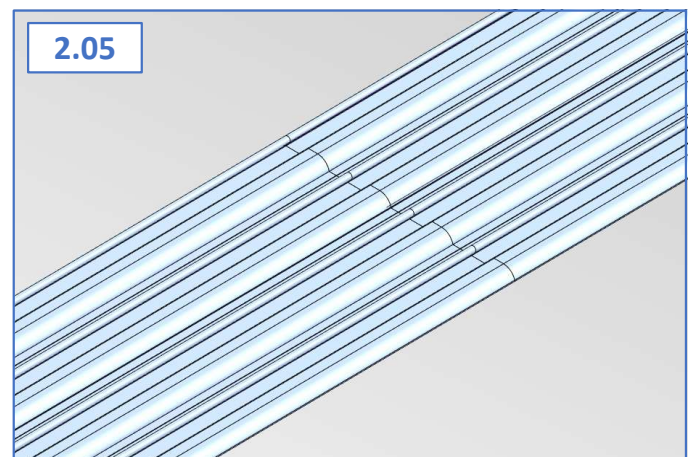
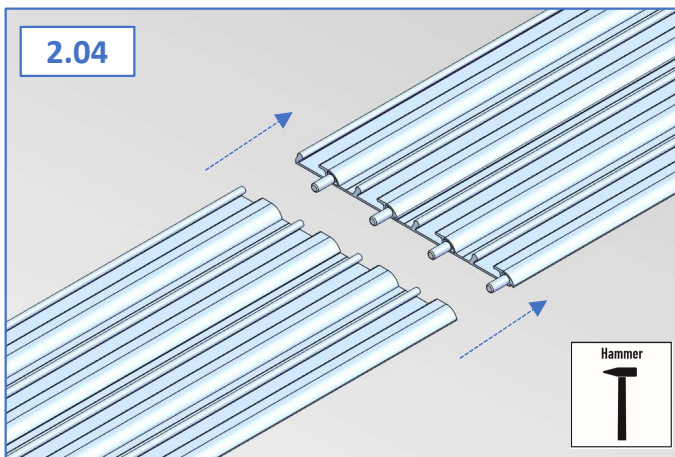
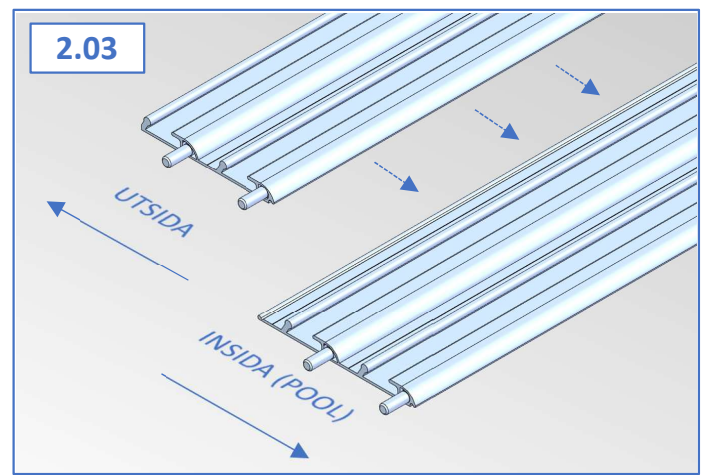
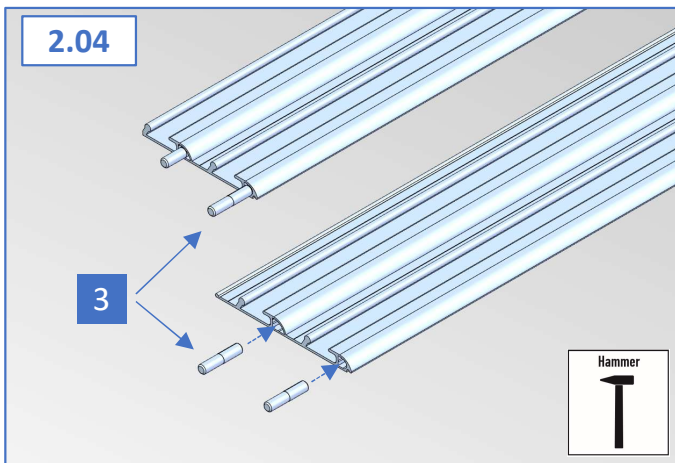

På hårt underlag (ej trä) ska  
hålen borraras med 6 mm borrar  
och sen 10 mm borrar under  
skenan och minst ett djup på  
60 mm  
\* Se bild 8.24 vid montering  
av stoppbit

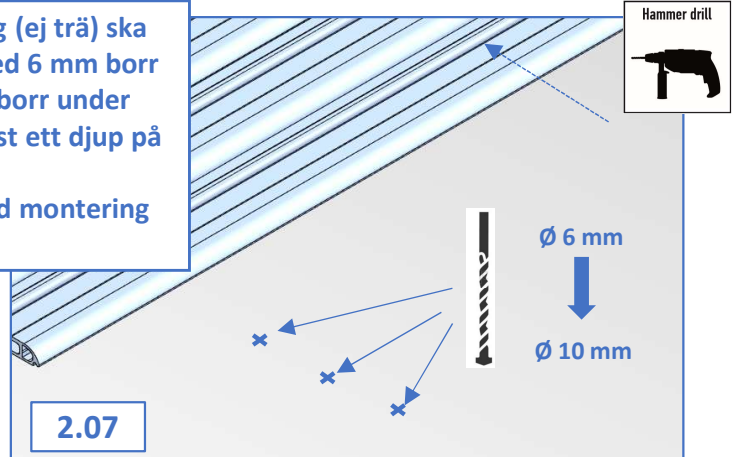

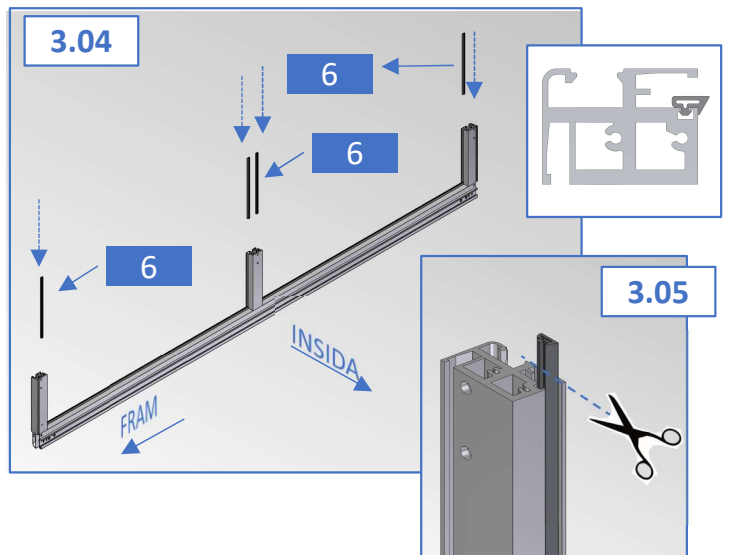
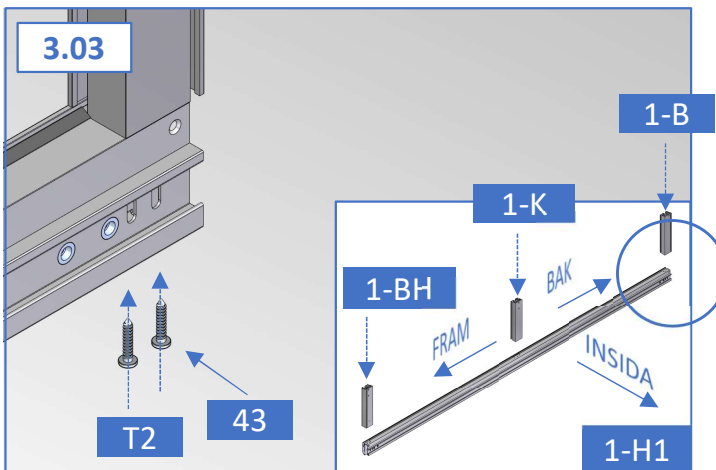
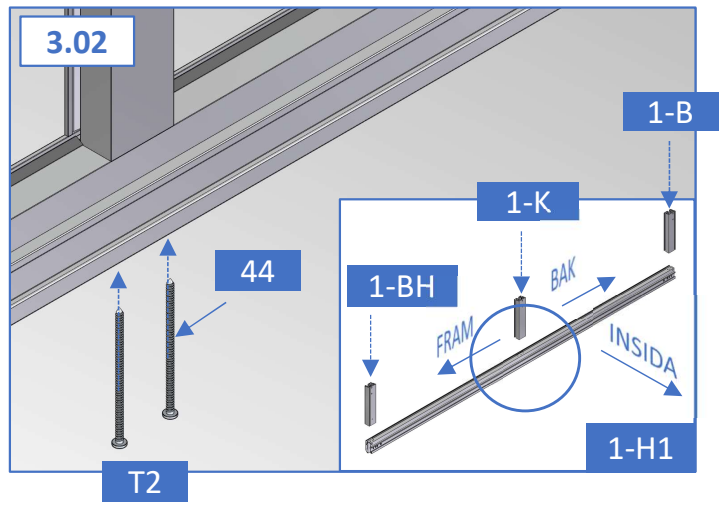
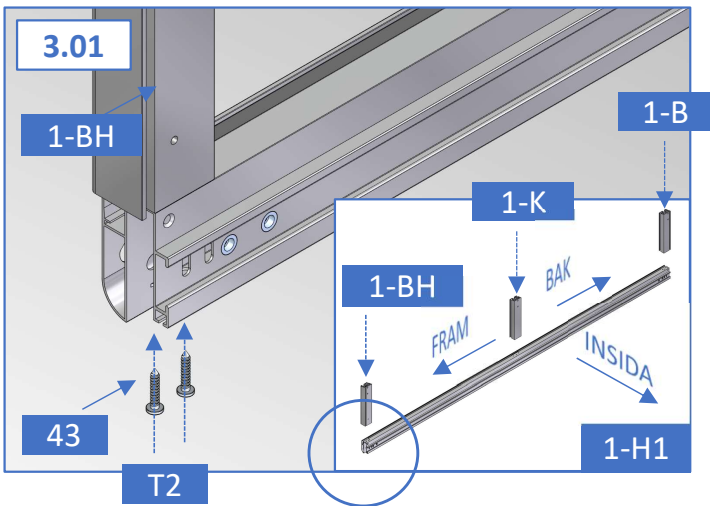
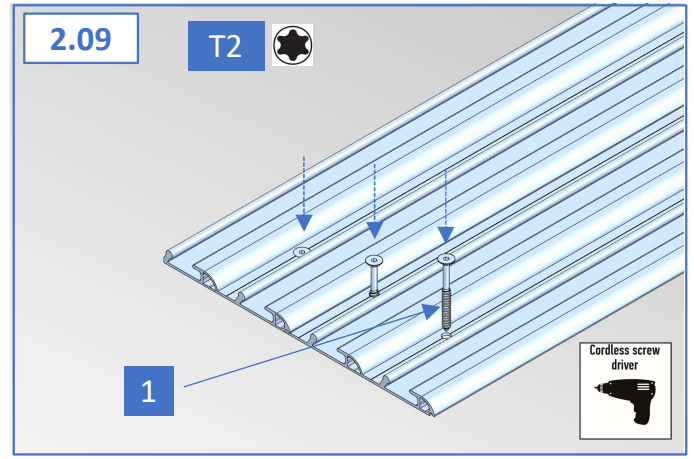
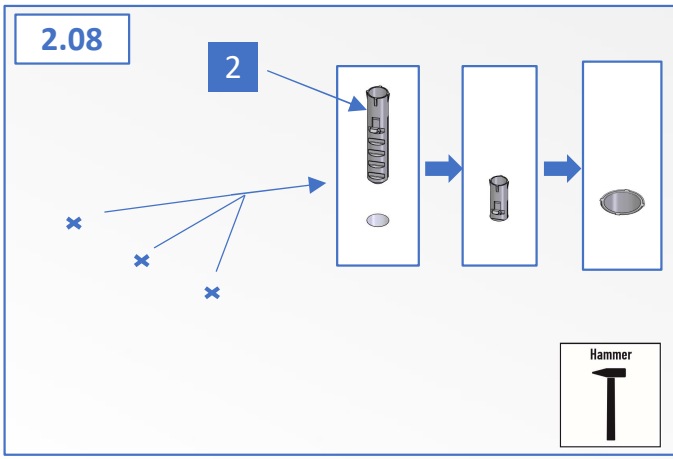

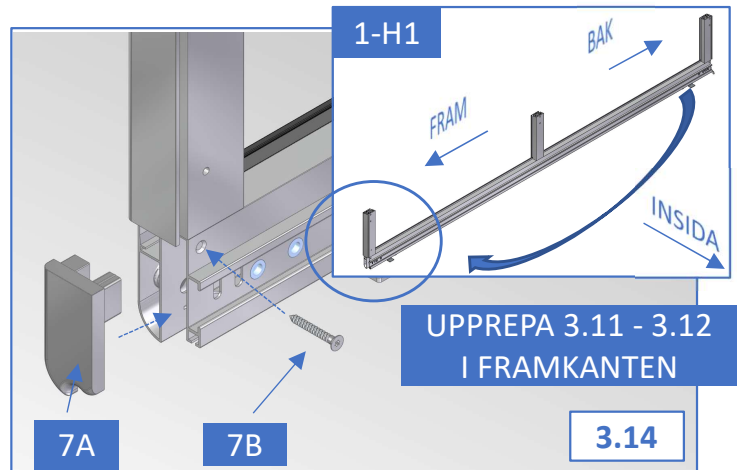
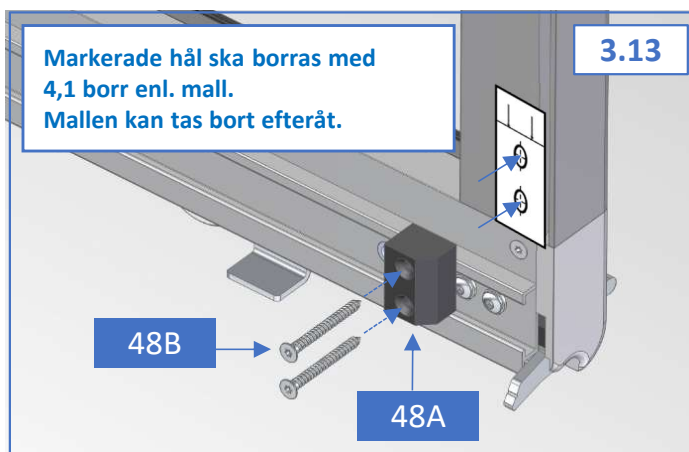
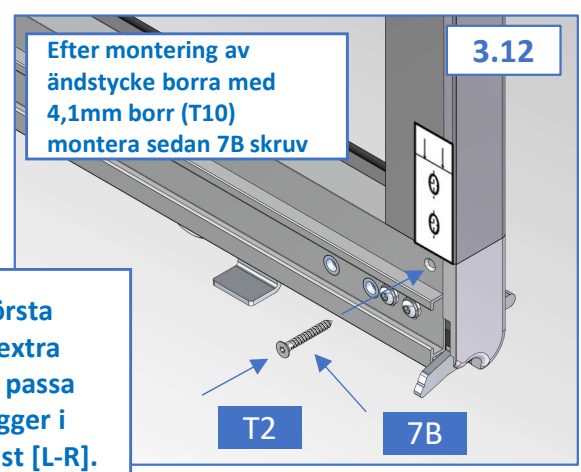
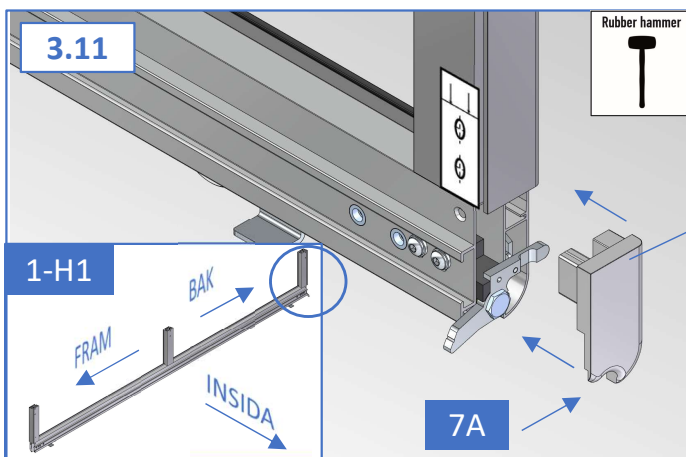
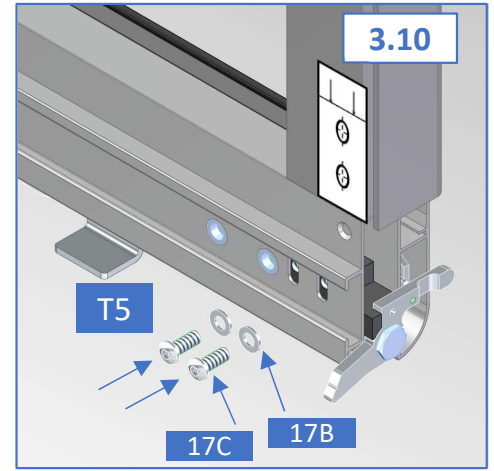
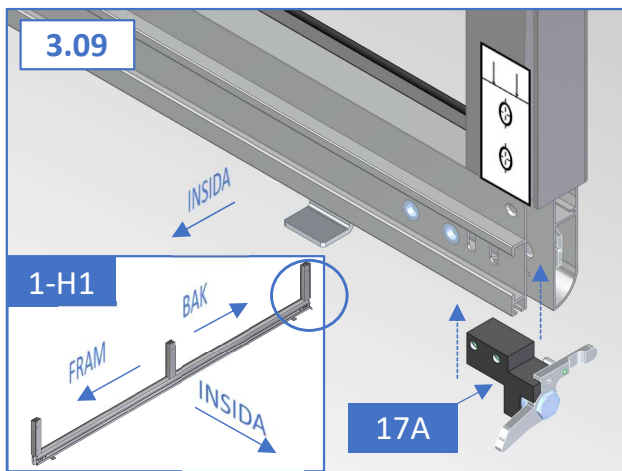
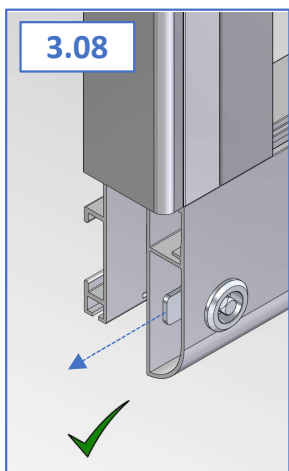
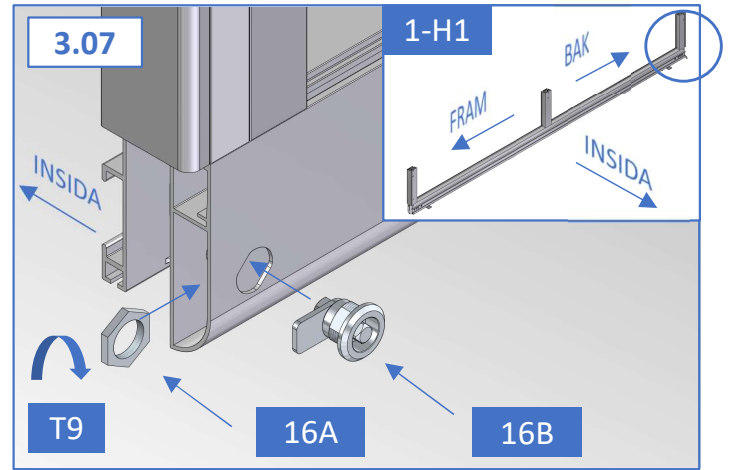
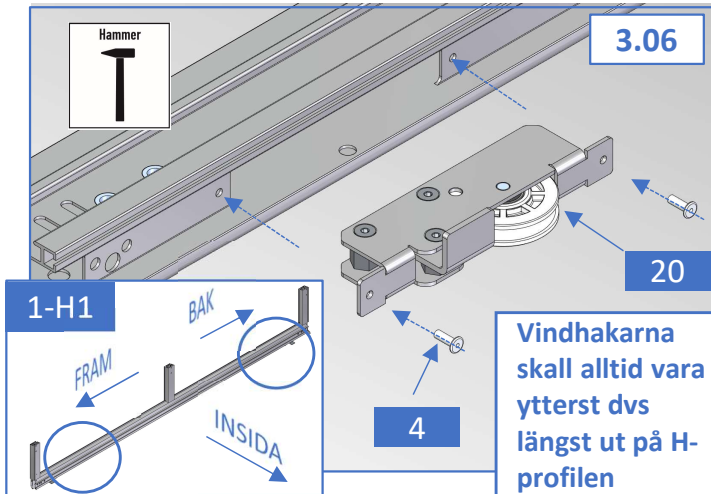



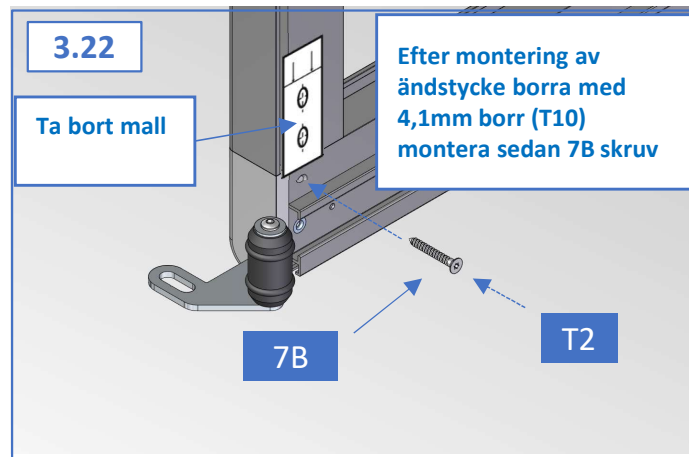
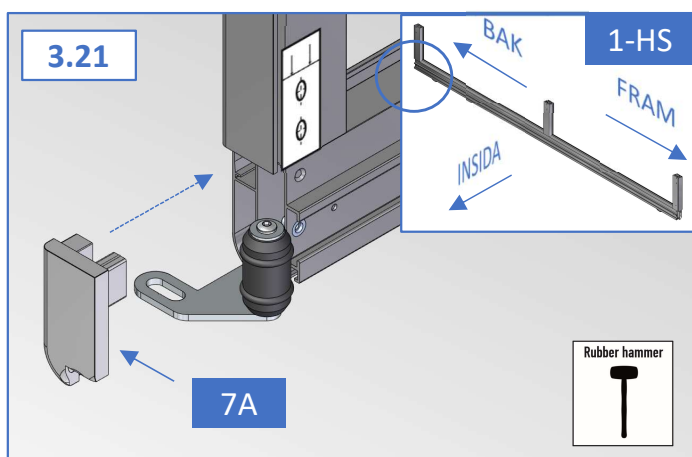
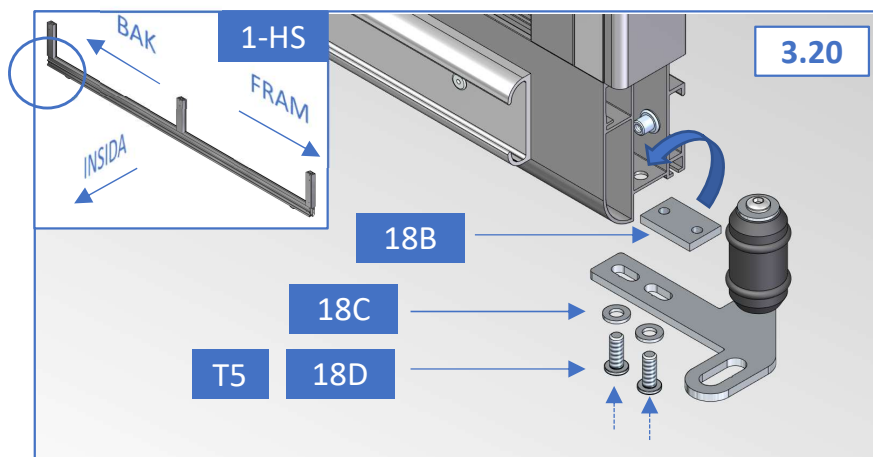
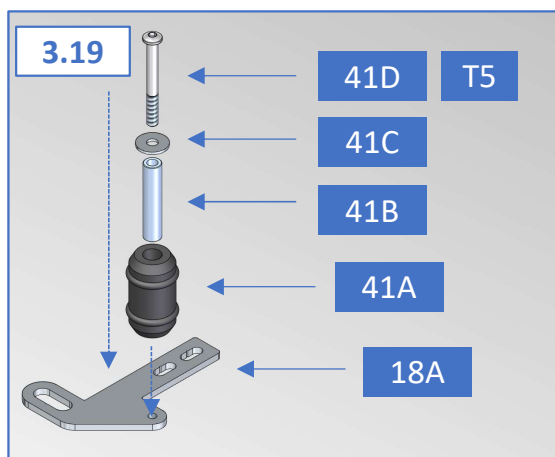
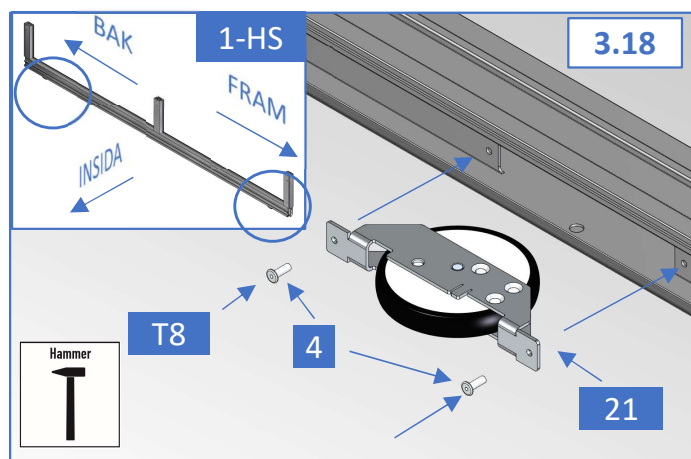
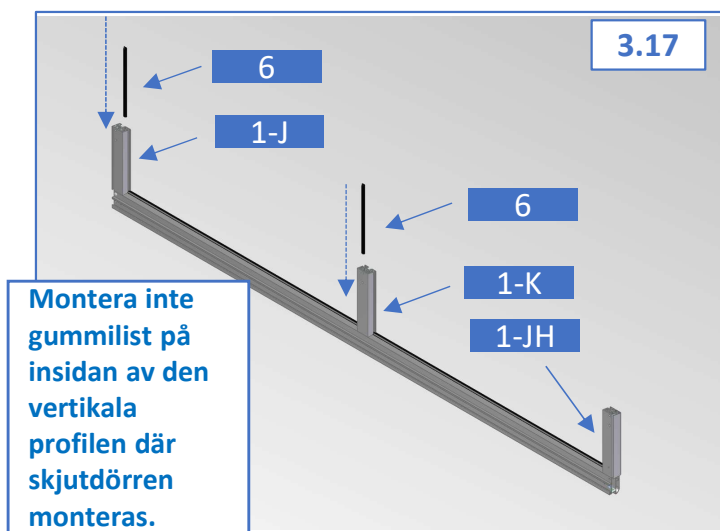
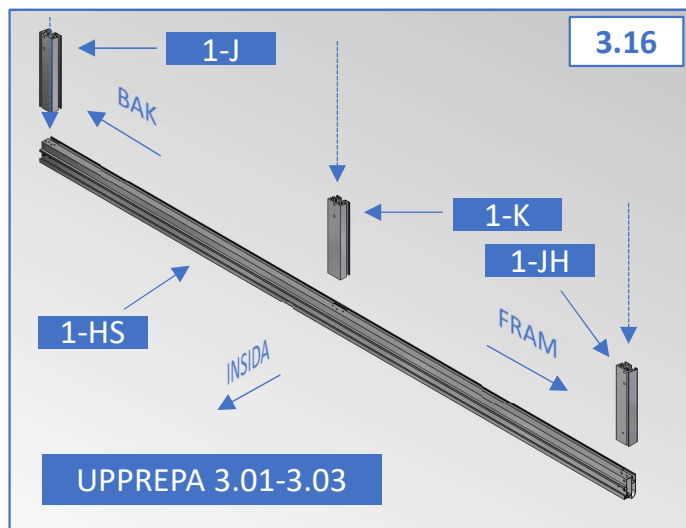
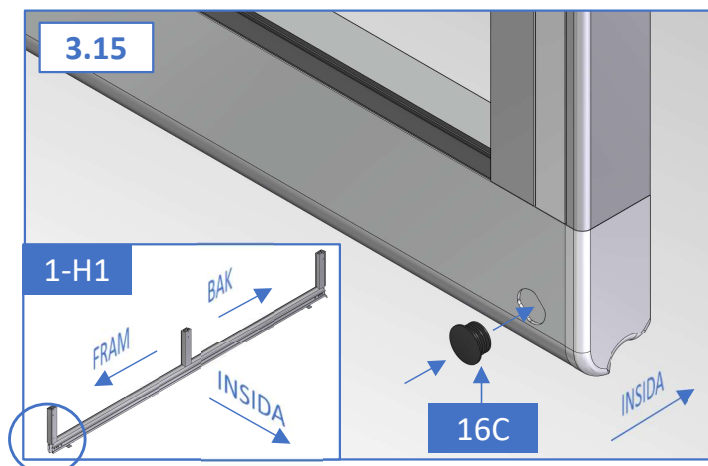



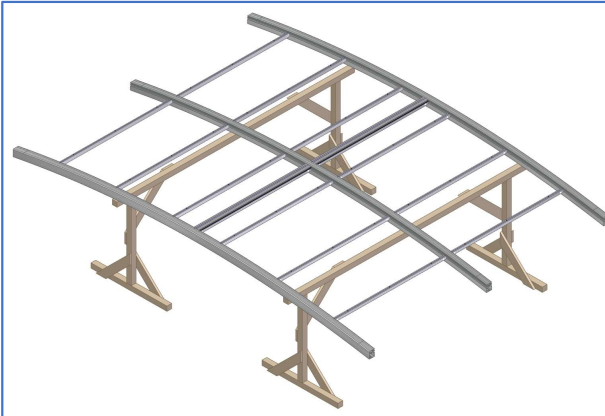
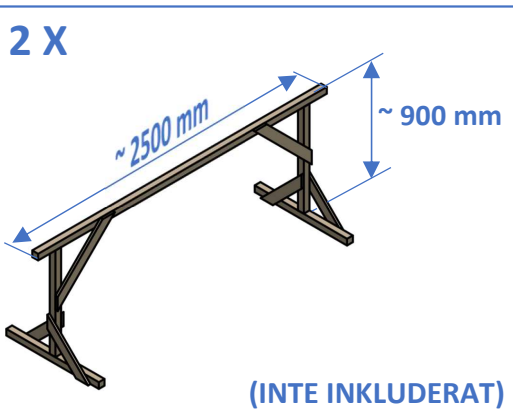
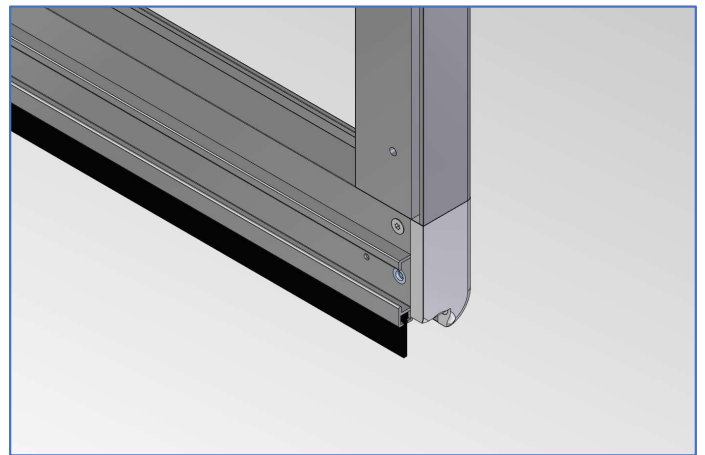
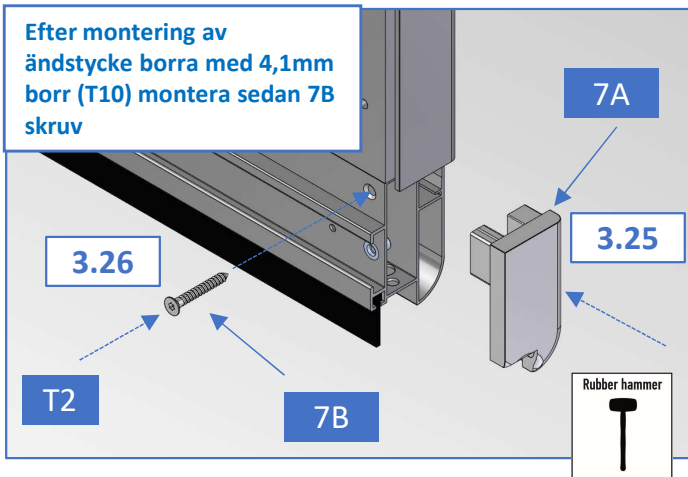
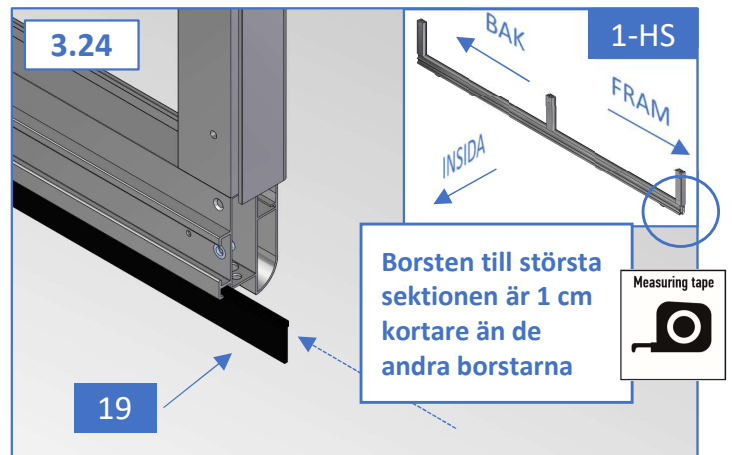
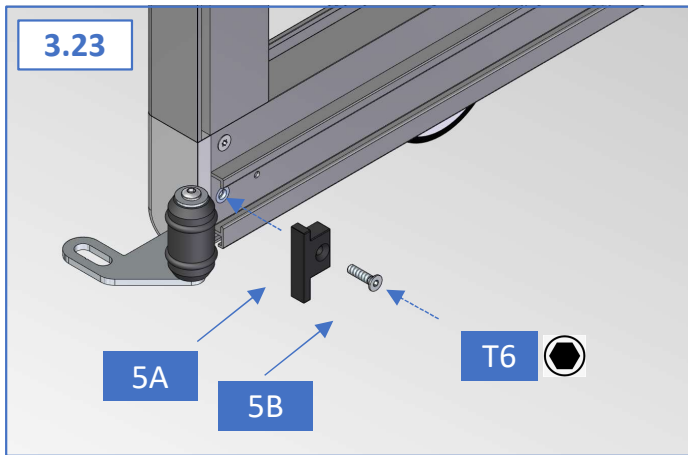

Vi rekommenderar för säkert och ergonomiskt arbete att följande moment utförs på bockar, som inte är inkluderade i boxen!

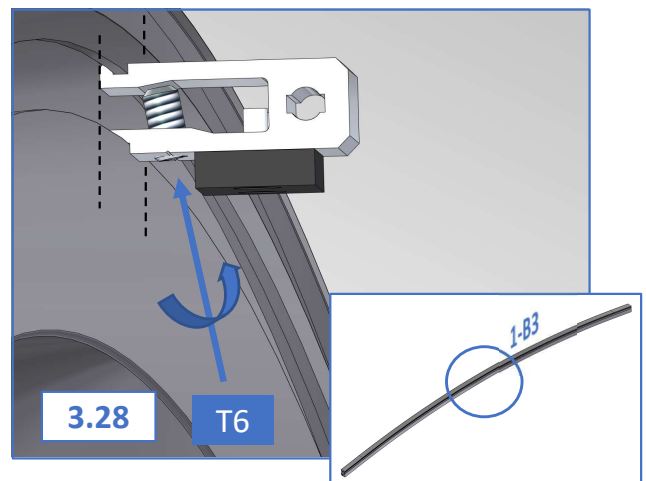
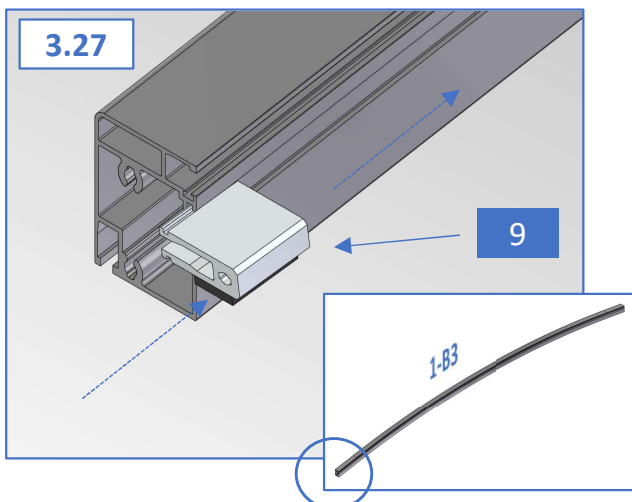

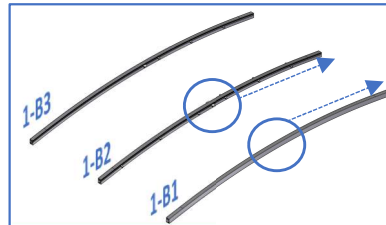
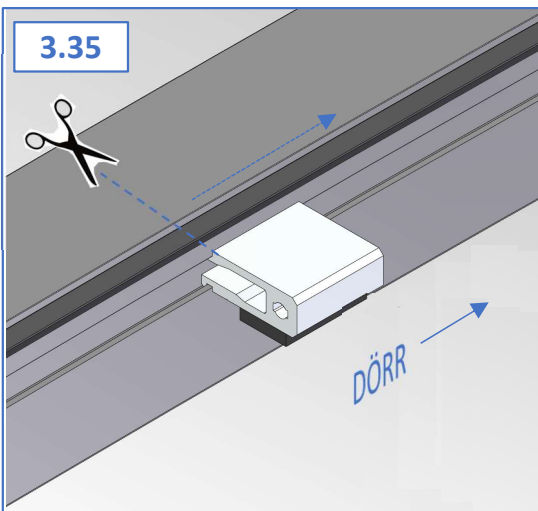
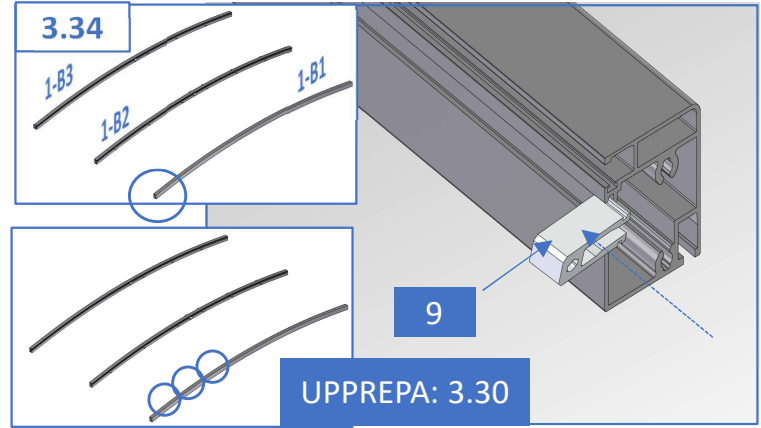
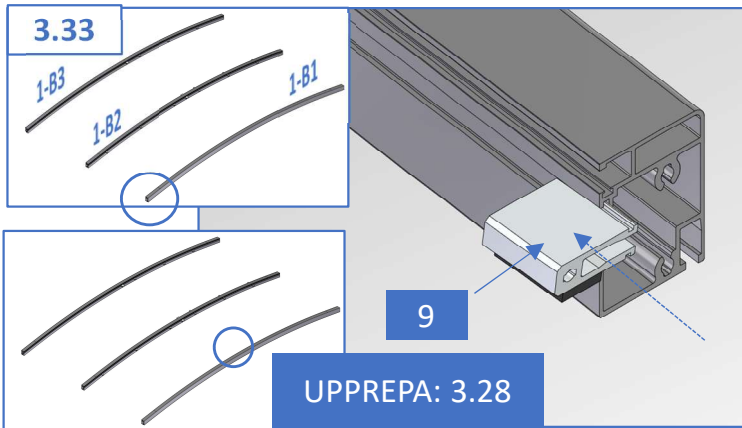
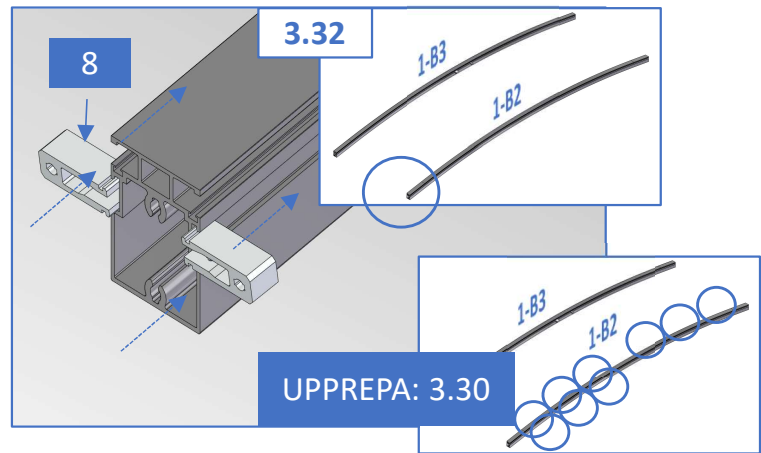
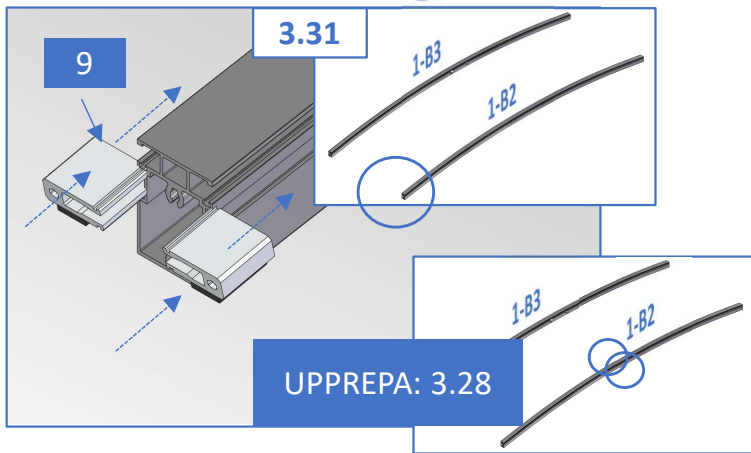
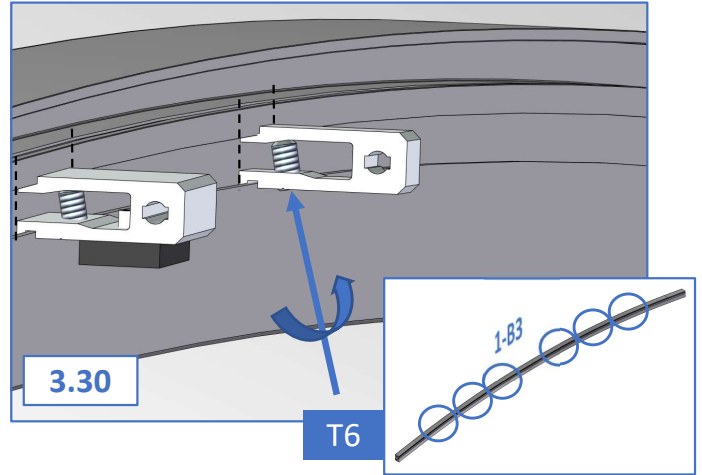
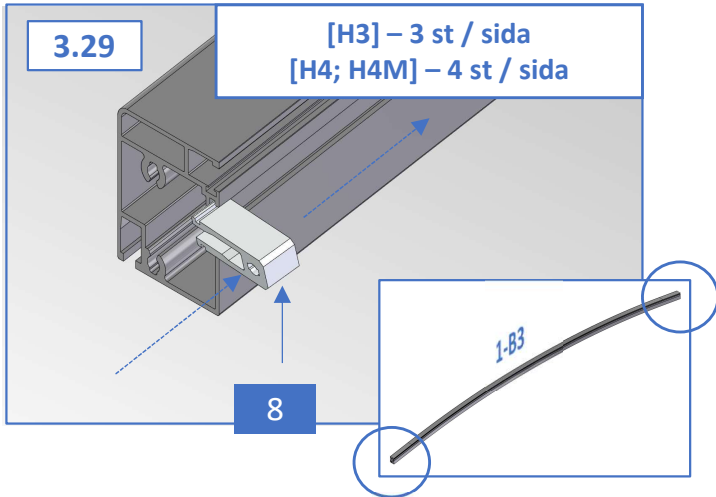

Klipp av insidans gummilist (nr 6) och ta bort det från profilen 1-B1 och 1-B2 där skjutdörren monteras.

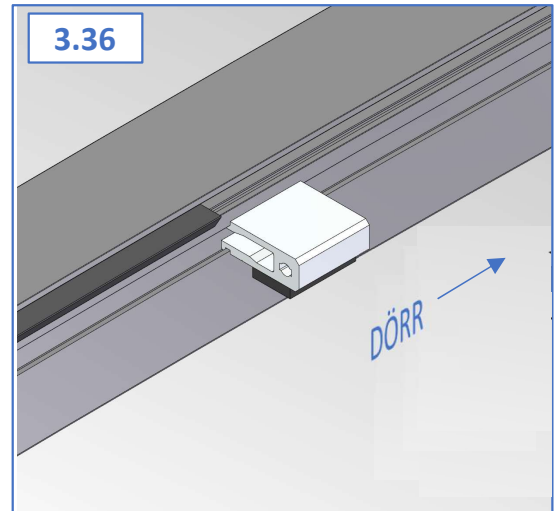

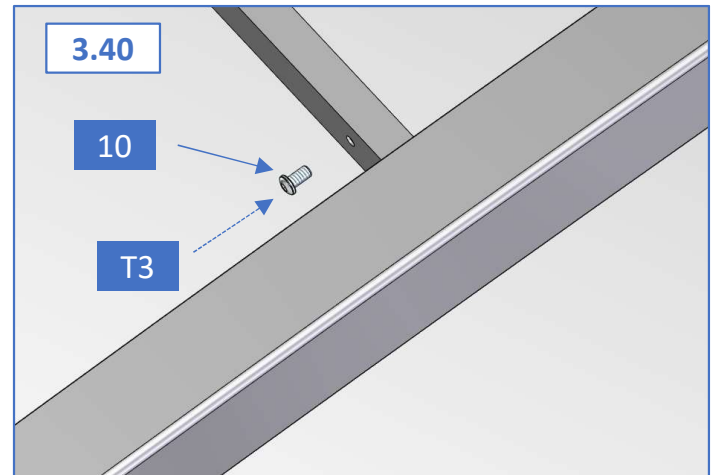
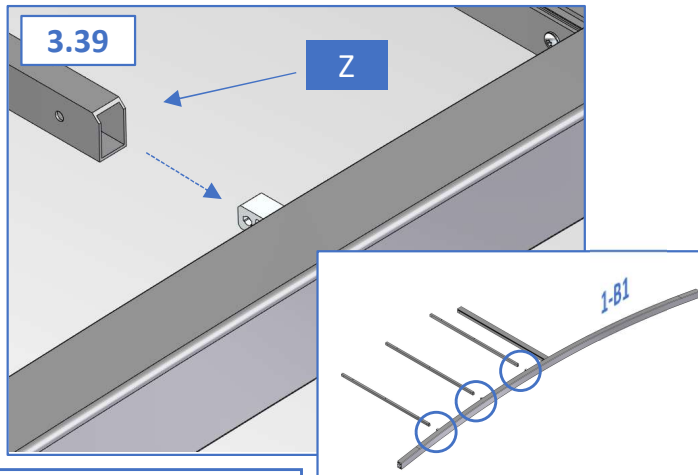
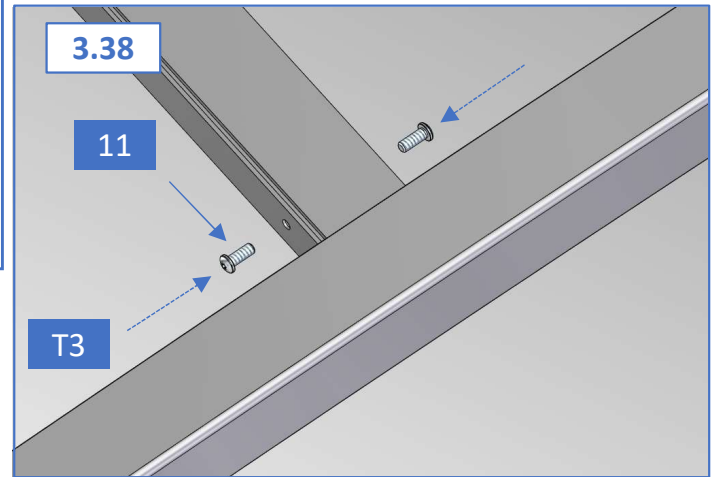
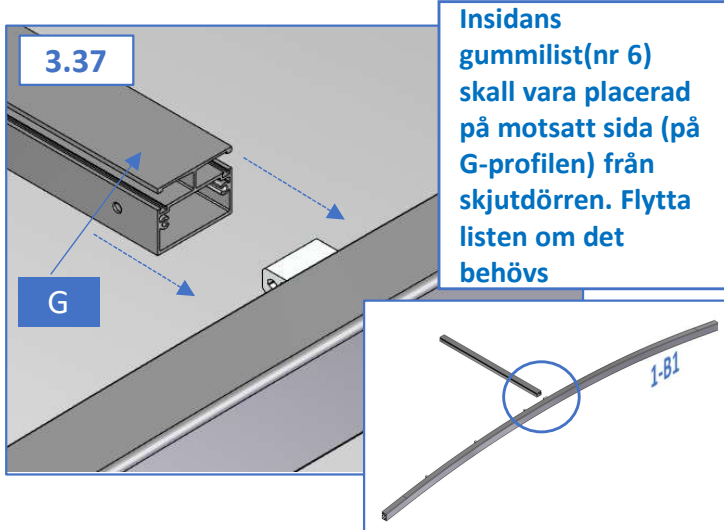

Montera bågprofilen på Z-profilerna en och en från ena änden till andra som en solfjäder. Två personer krävs.

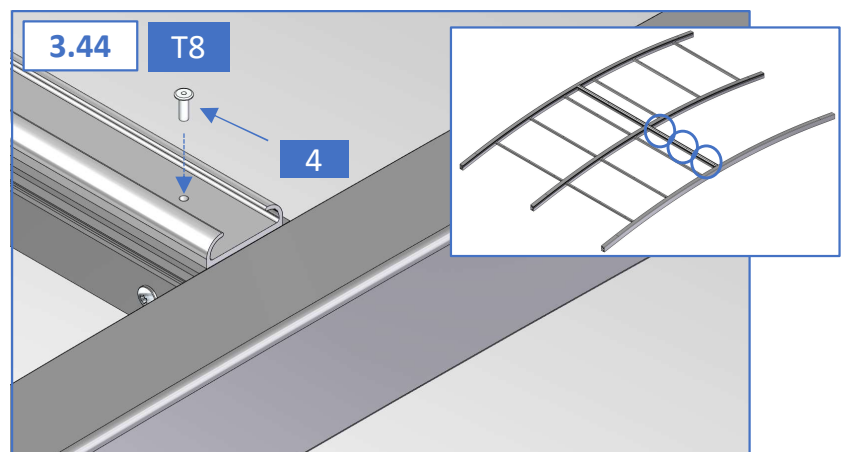
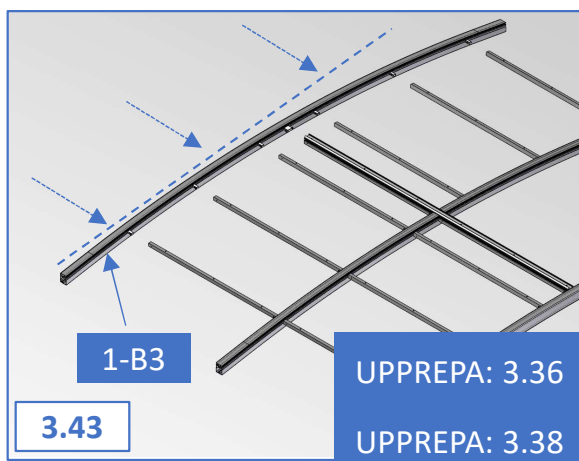
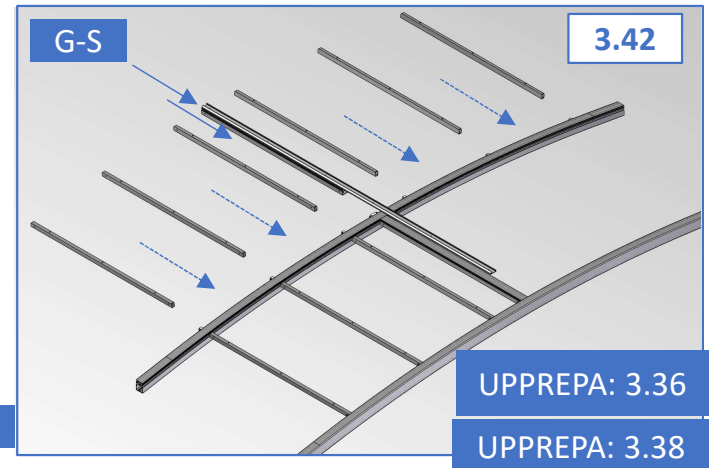
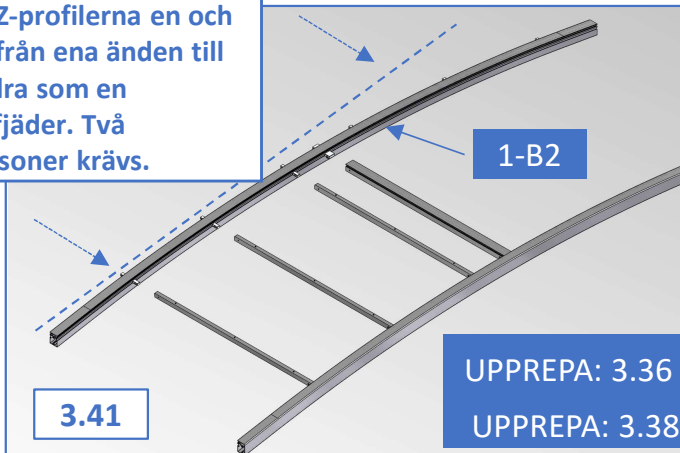

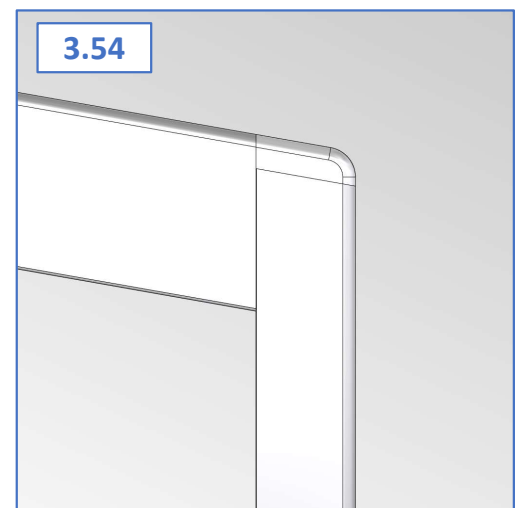
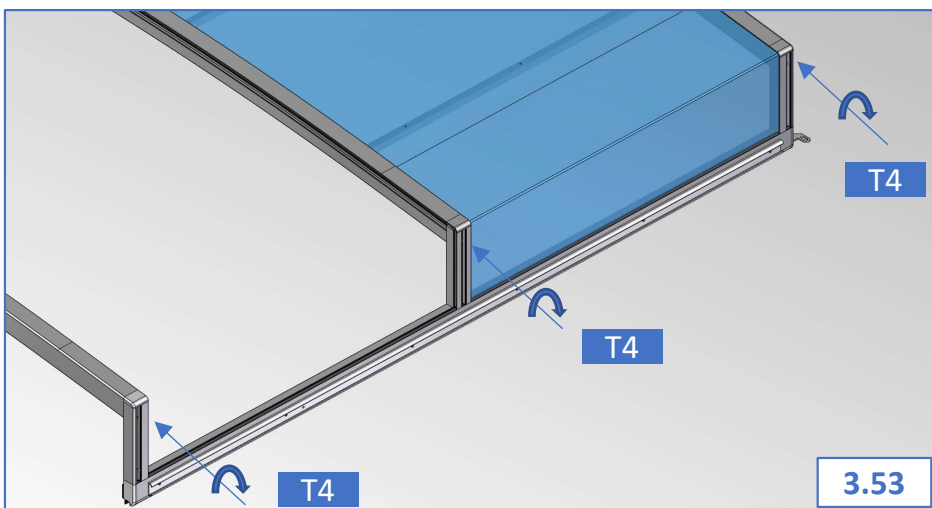
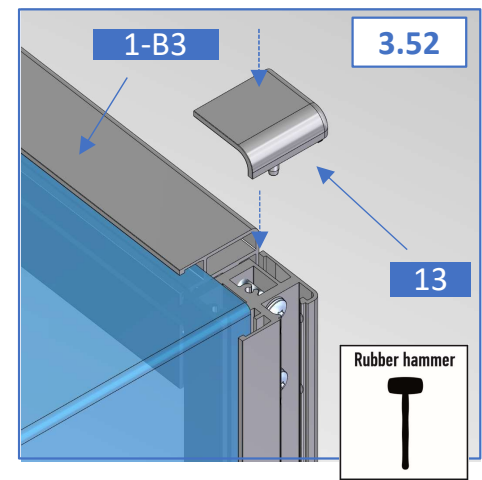
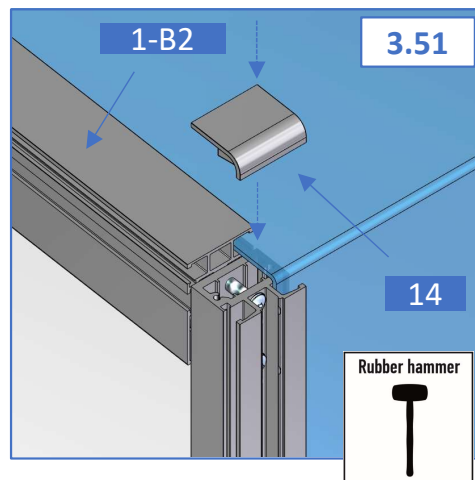
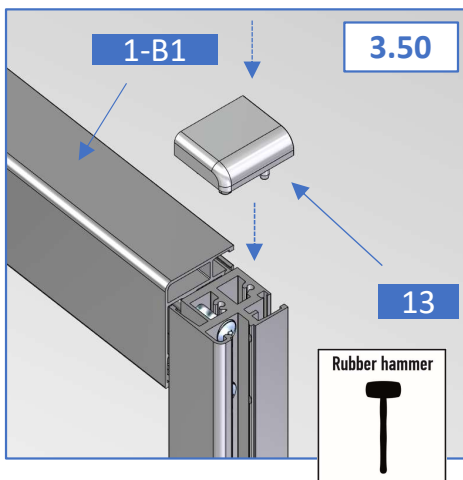
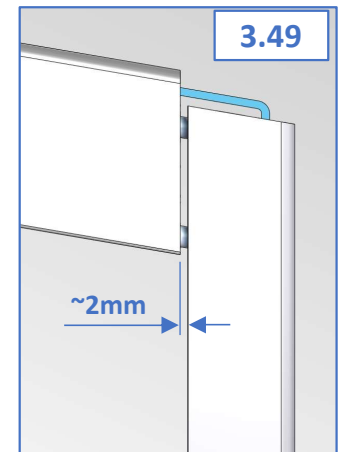
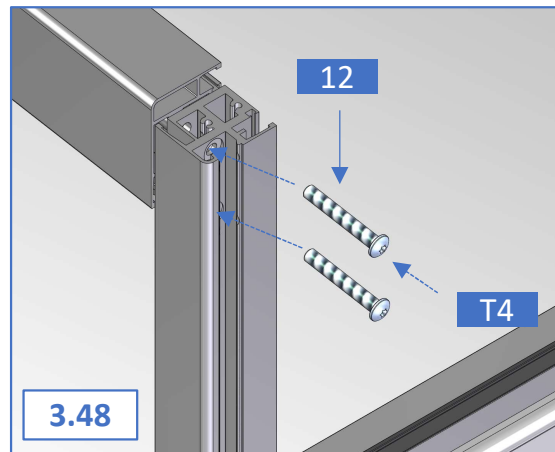
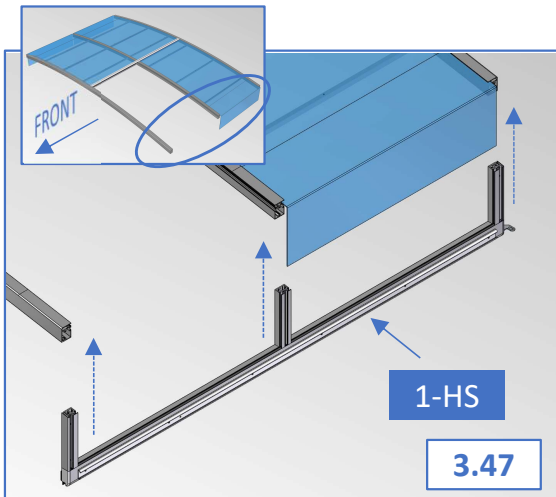
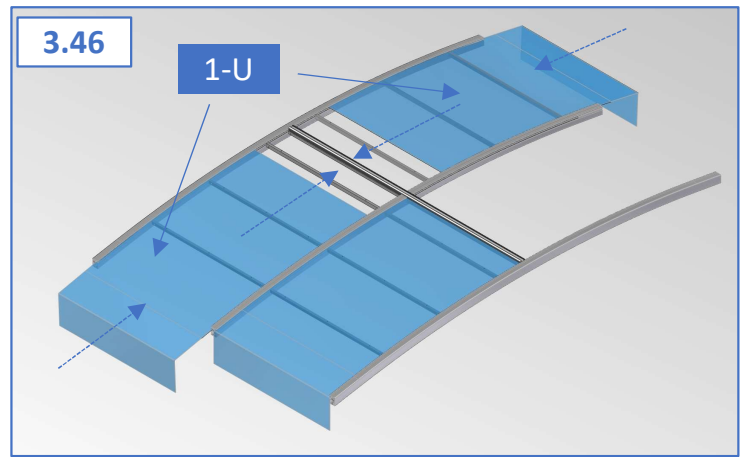
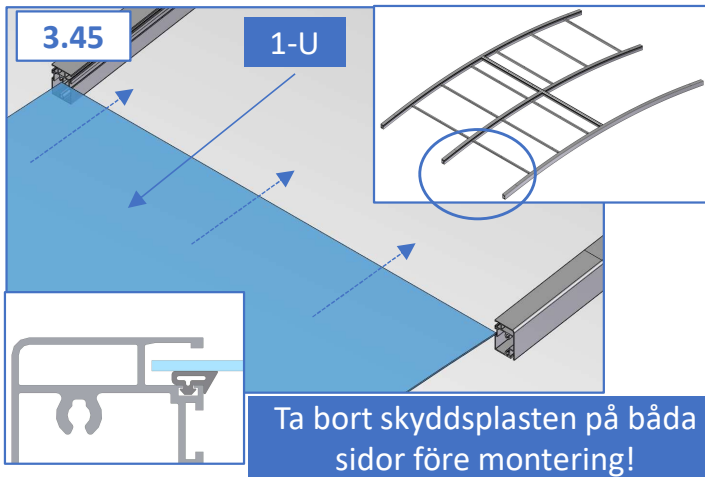



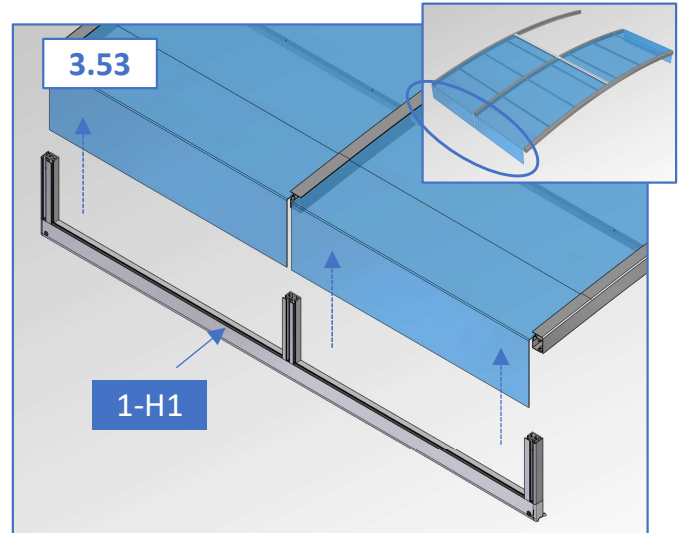
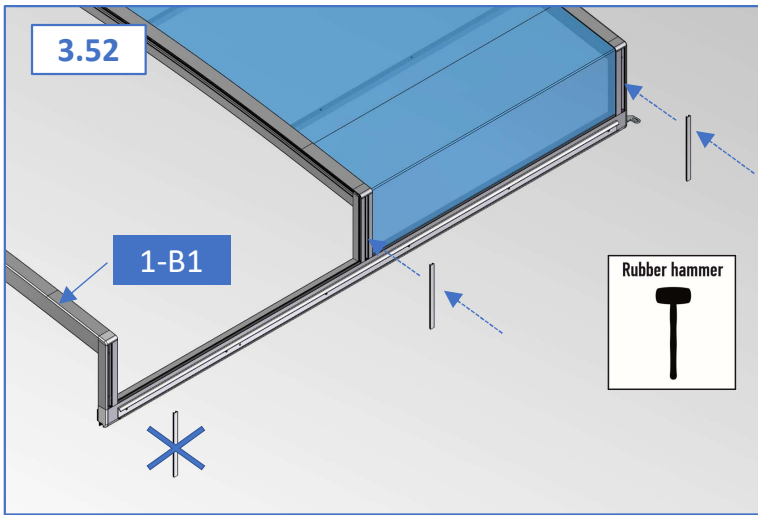

UPPREPA: 3.45 – 3.52

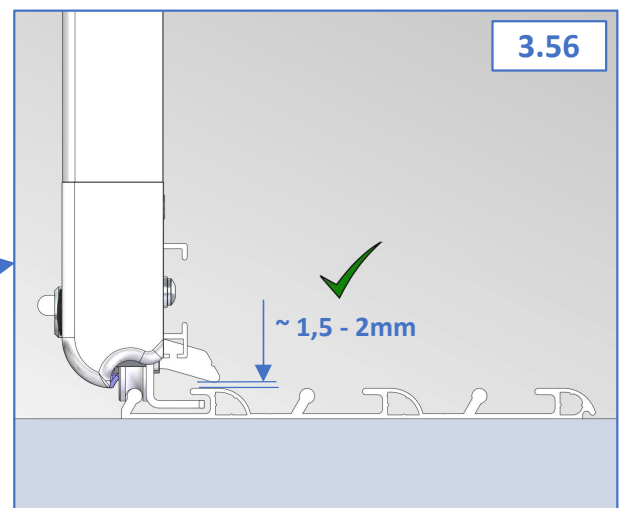
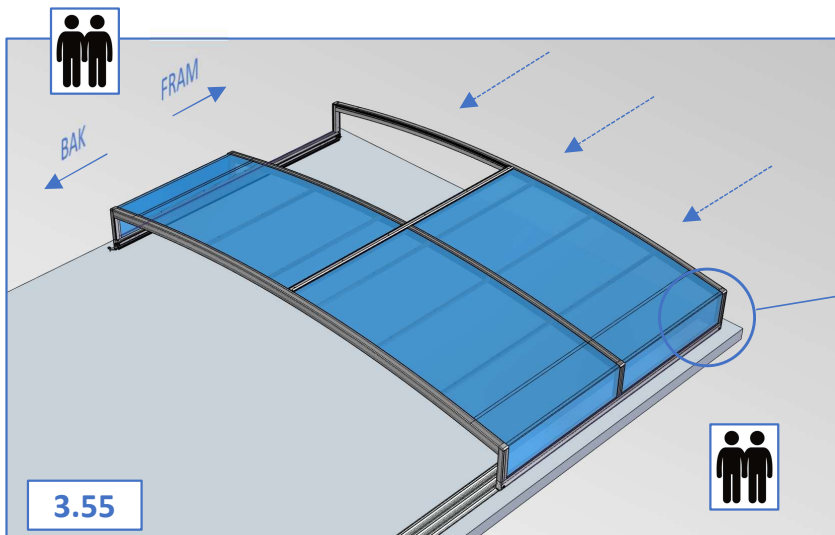
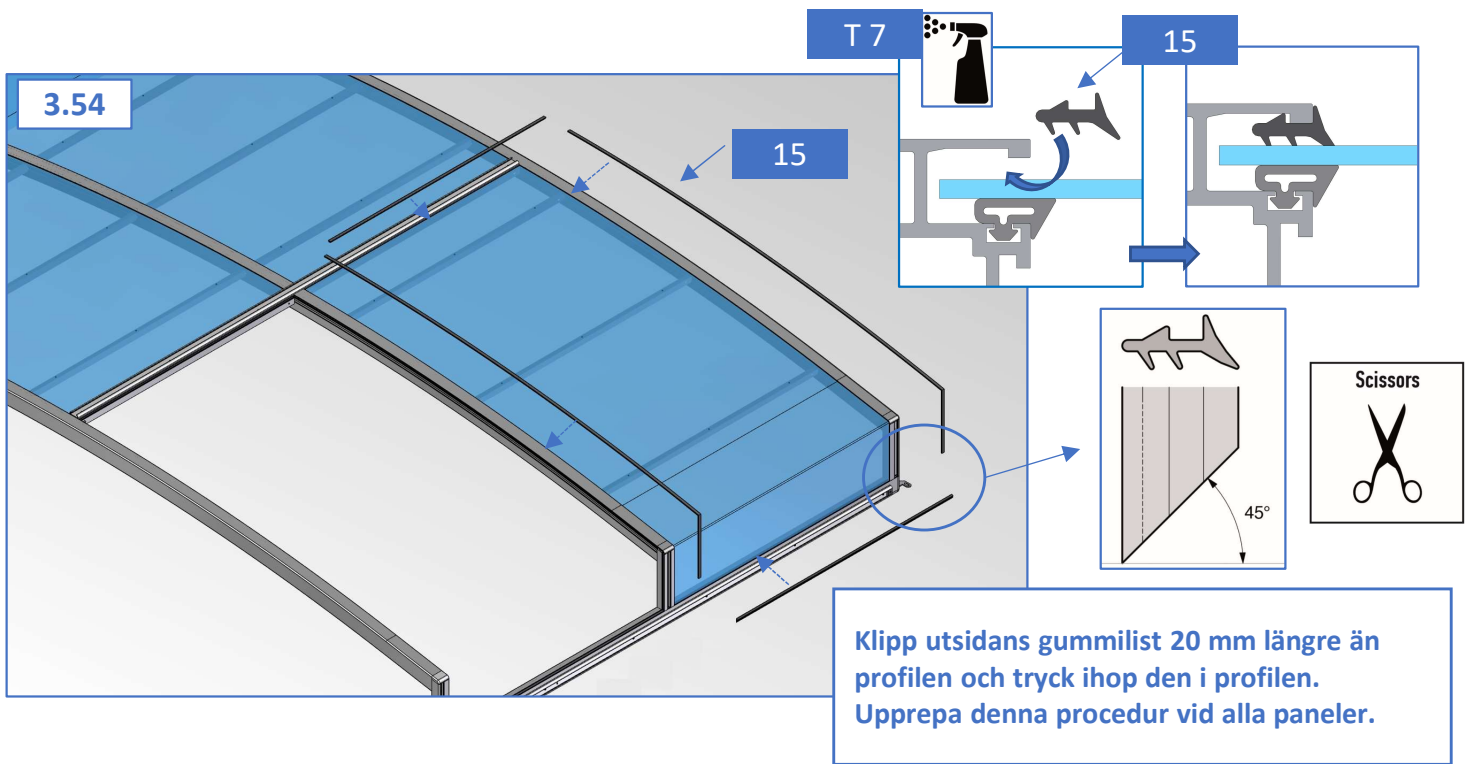



X\* = Vilken sektion  
räknat från den största  
Ex. andra sektion = 2-K

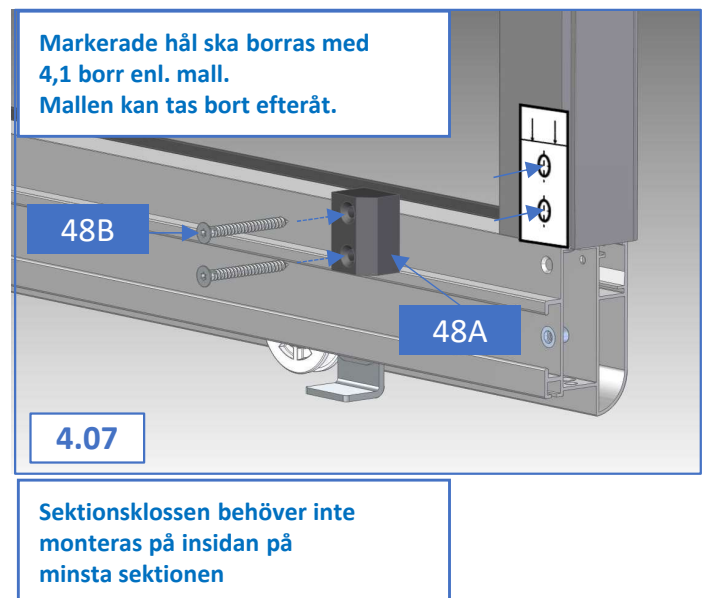
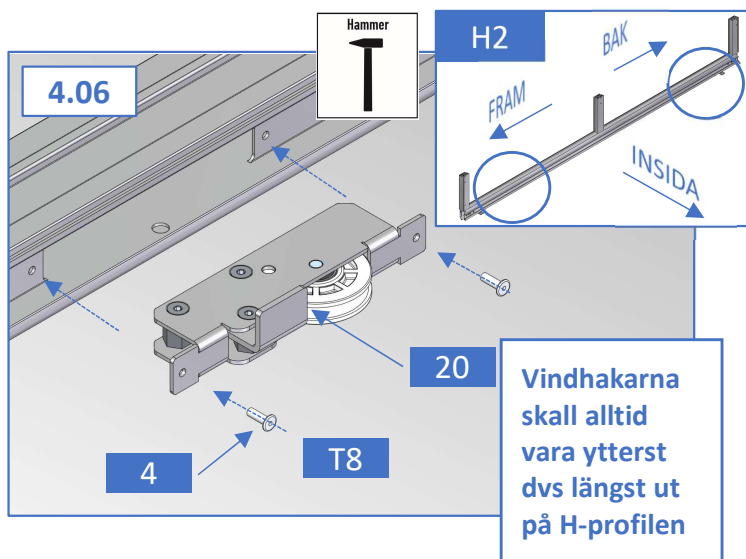
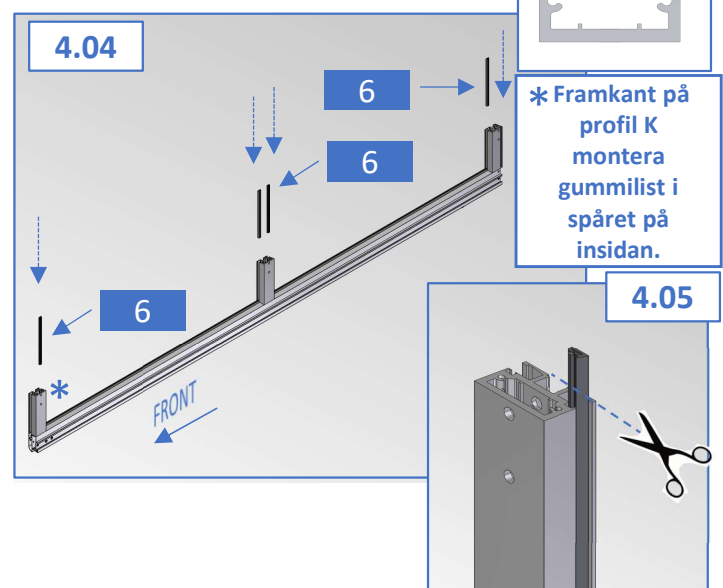
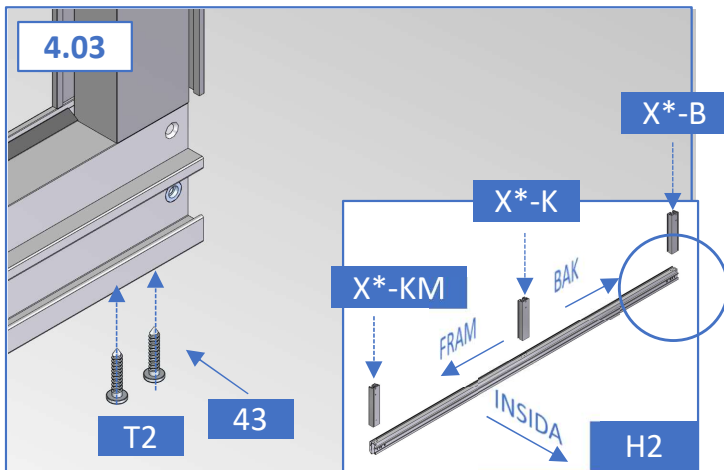
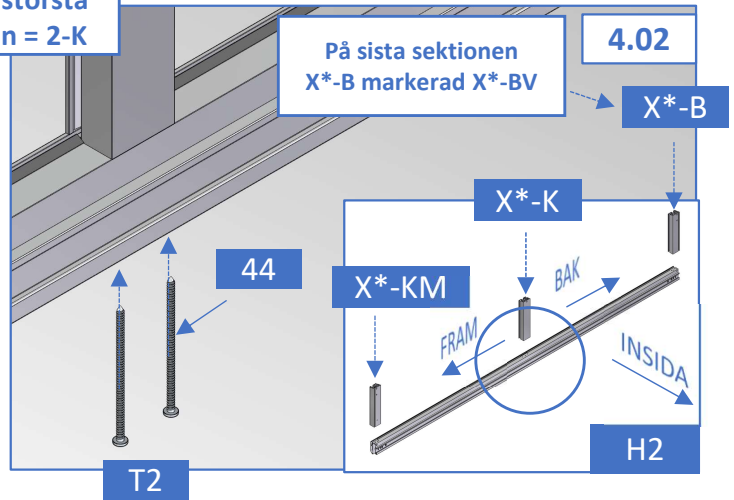
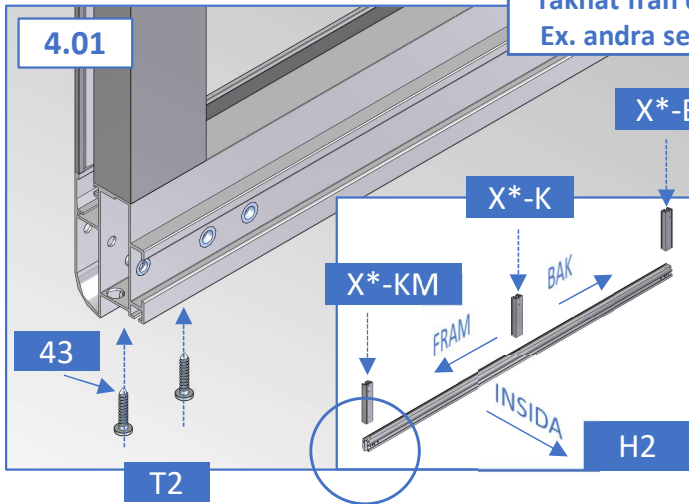

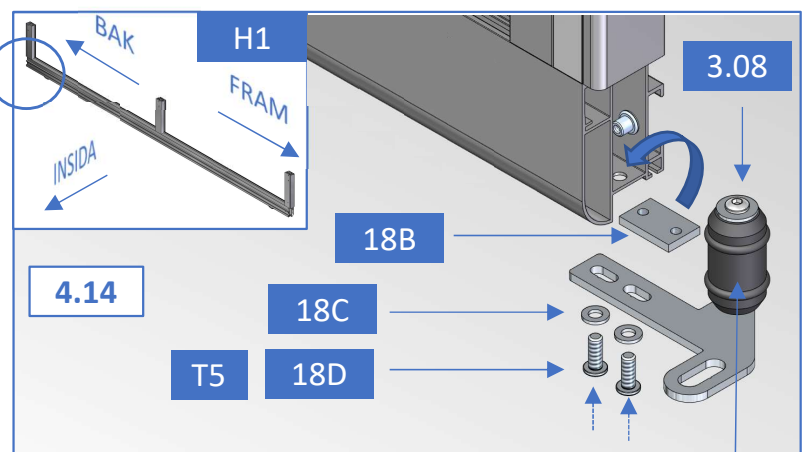
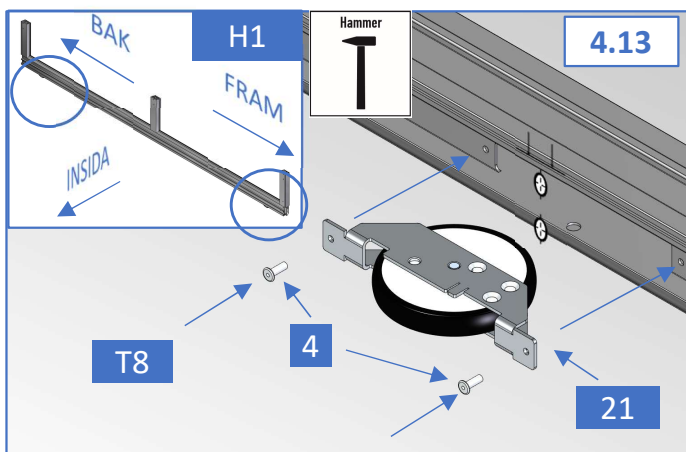
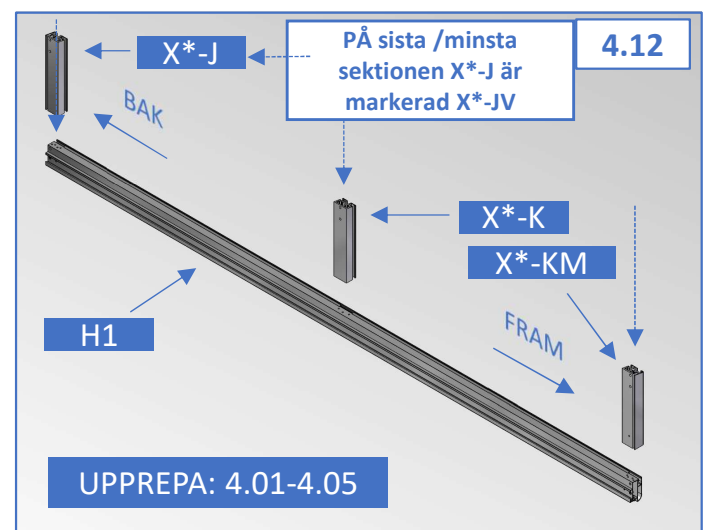
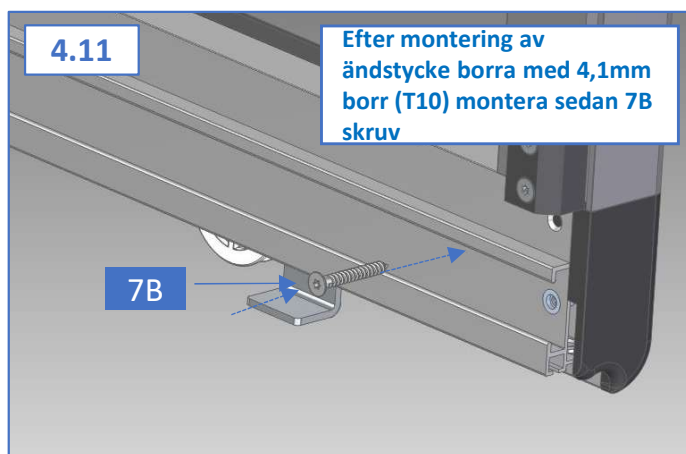
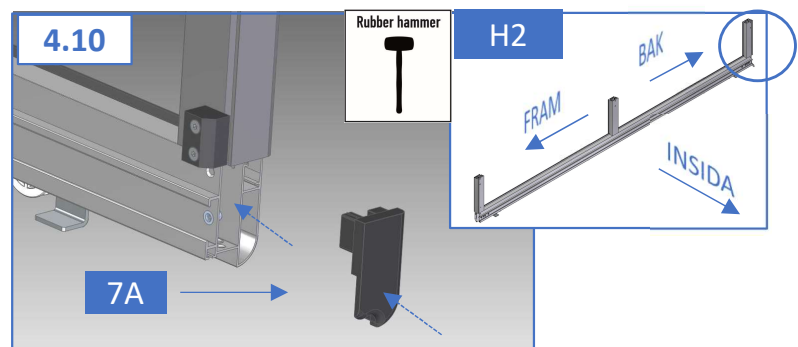
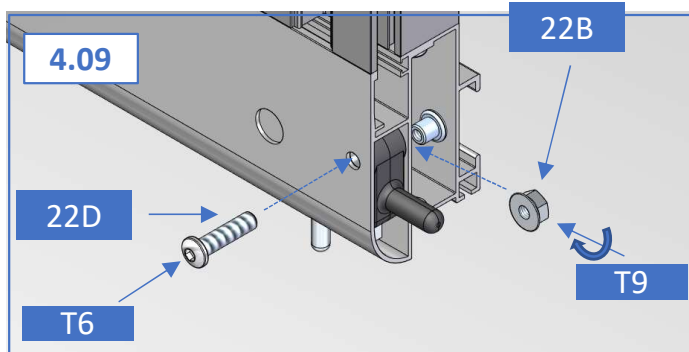
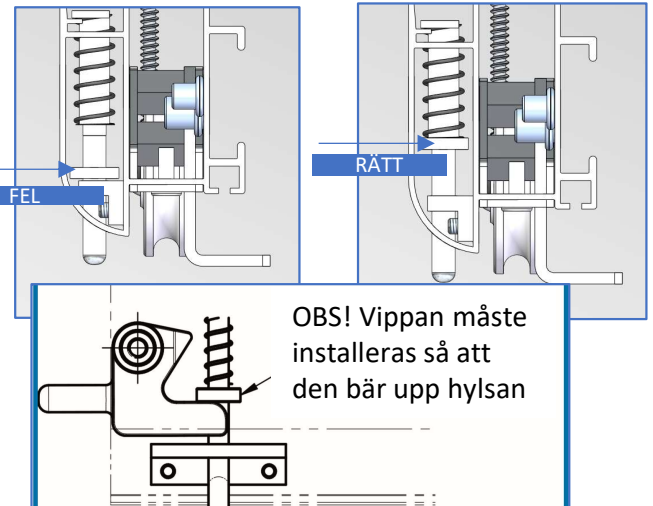
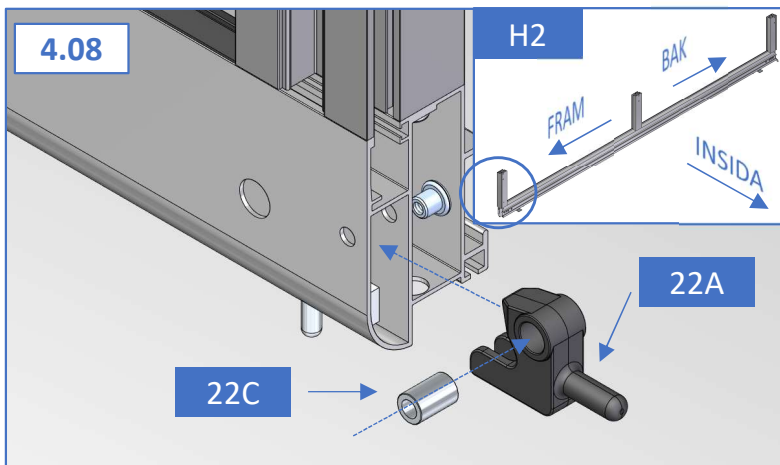

Installera inte stödrulle (Nr. 41.) på minsta sektionen

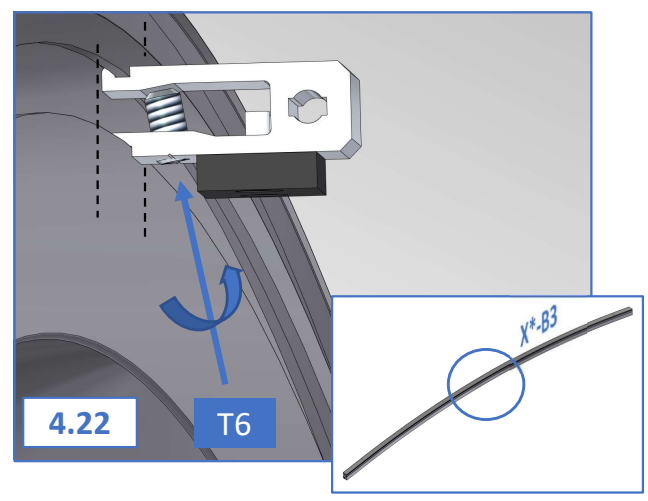
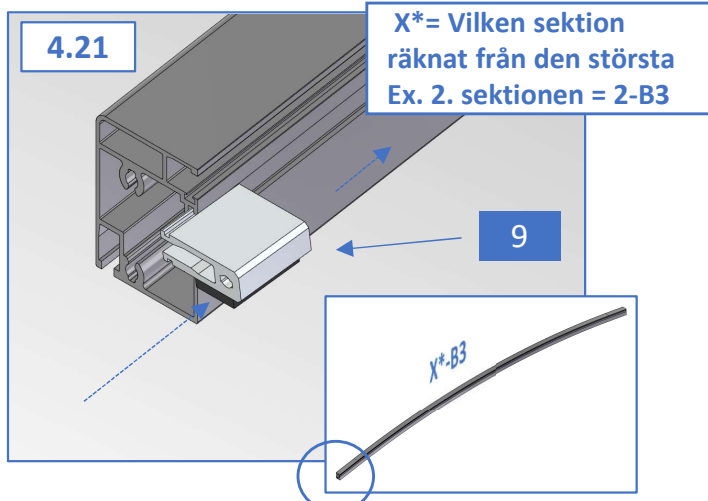
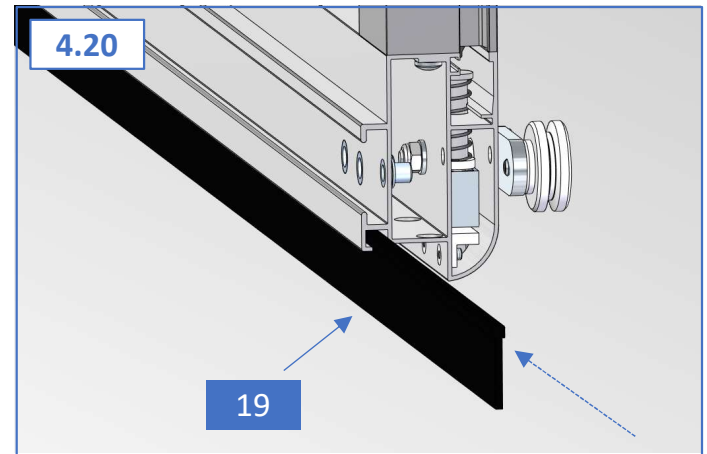
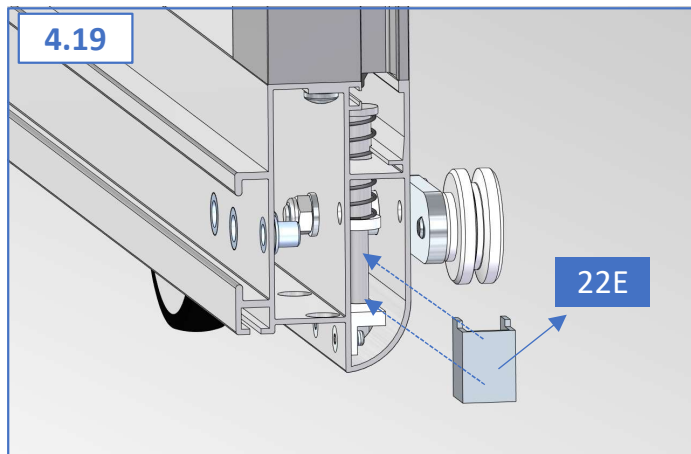
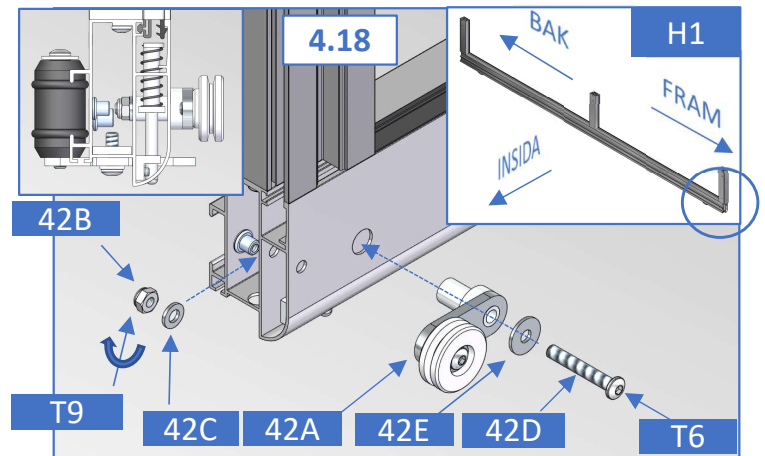
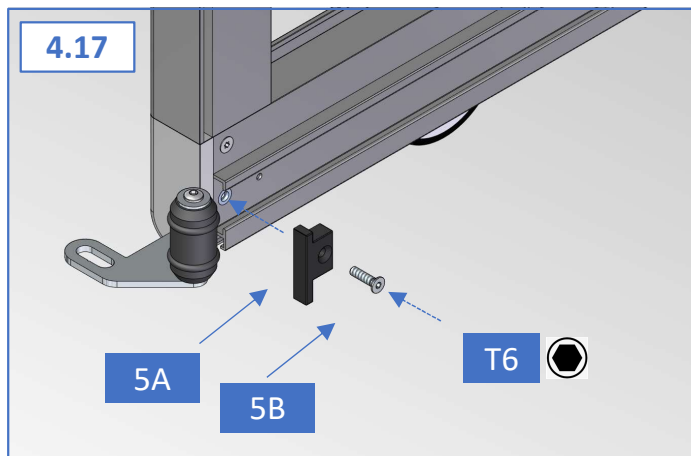
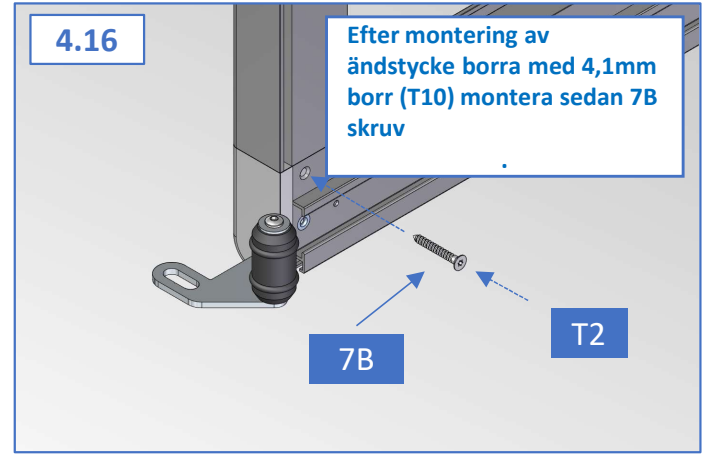
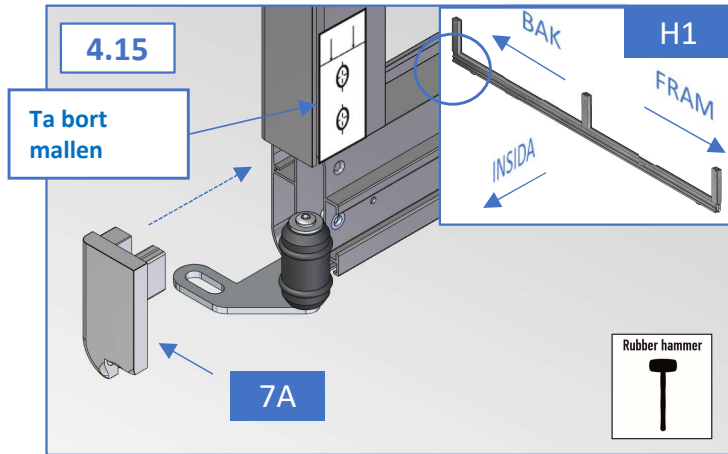



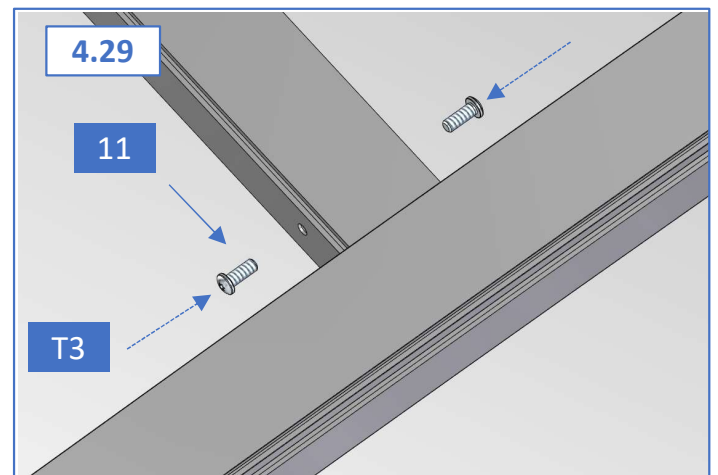
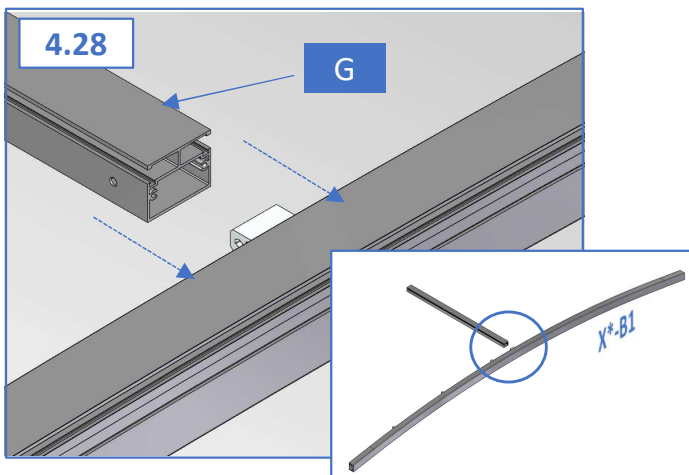
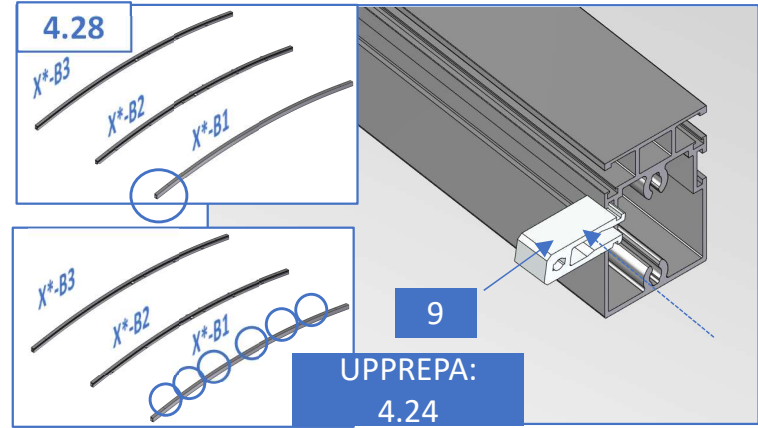
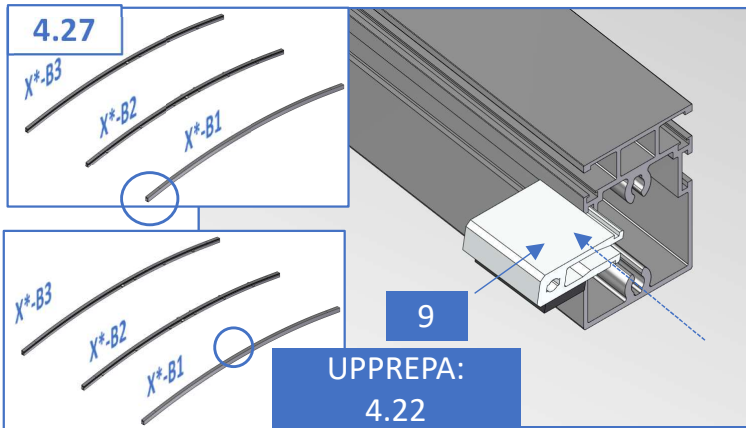
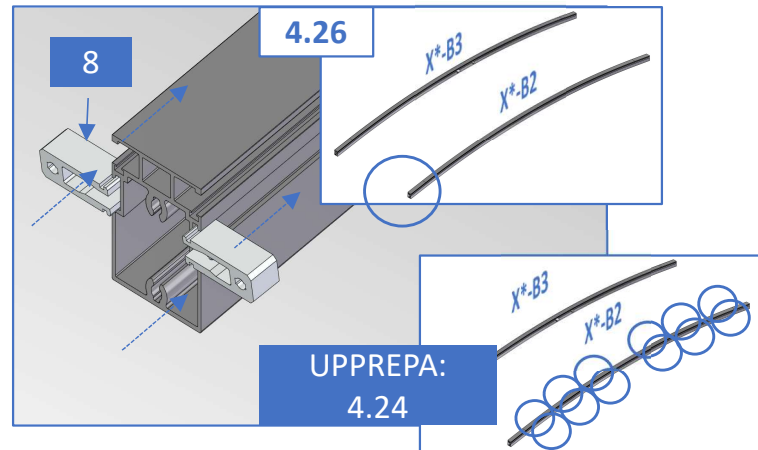
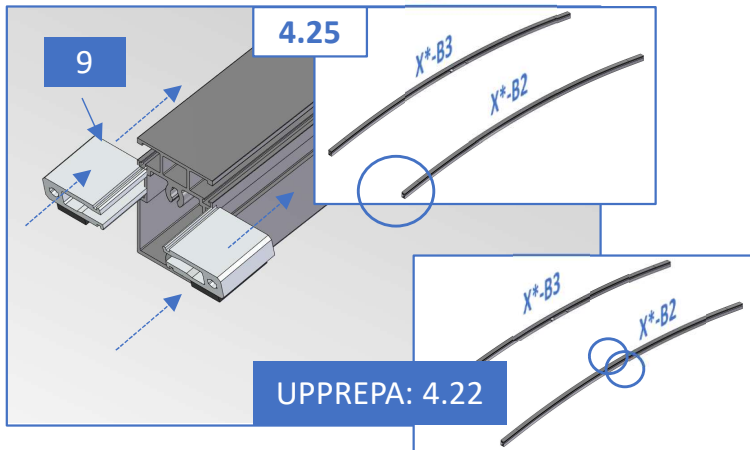
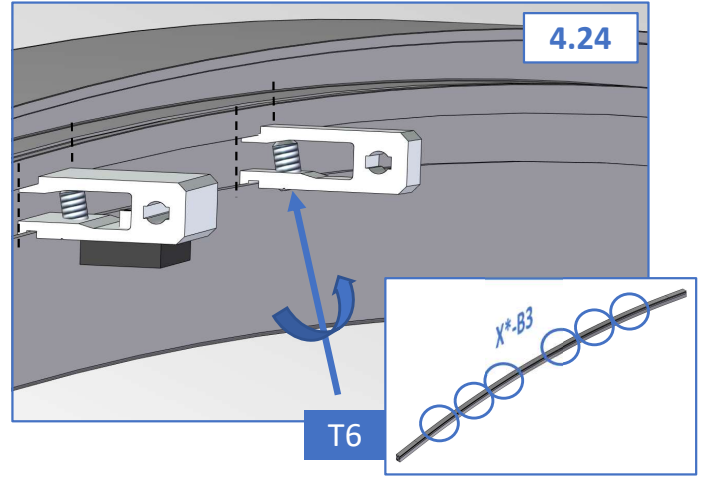
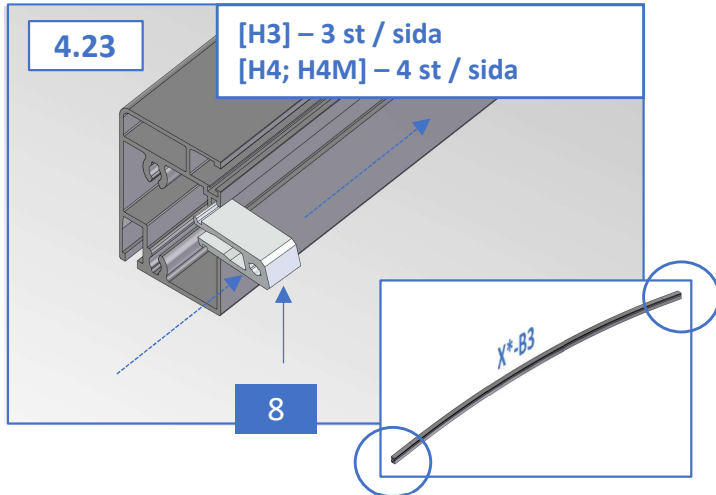

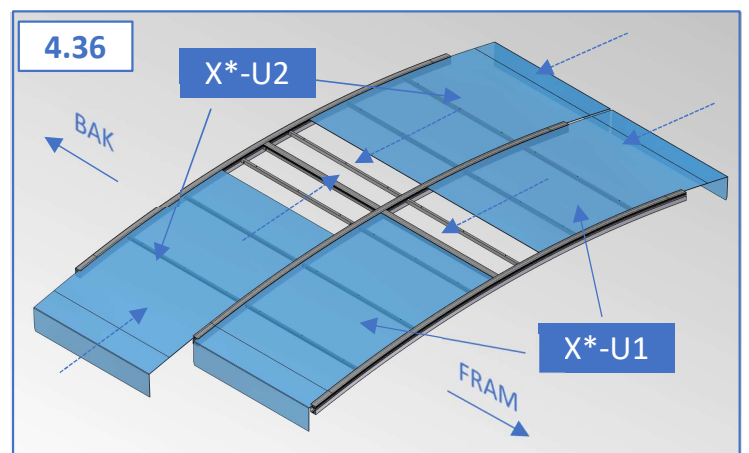
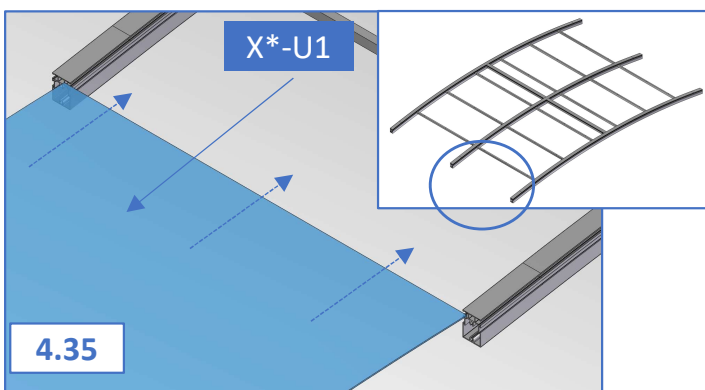
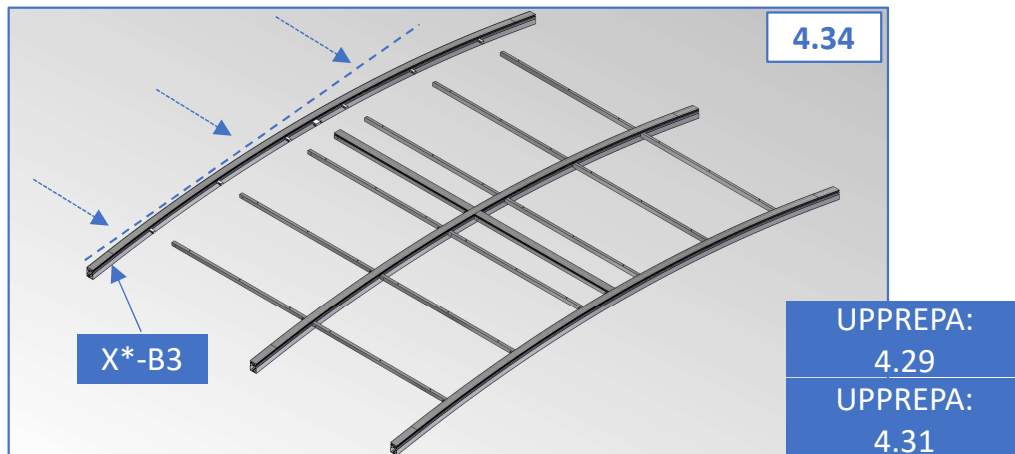
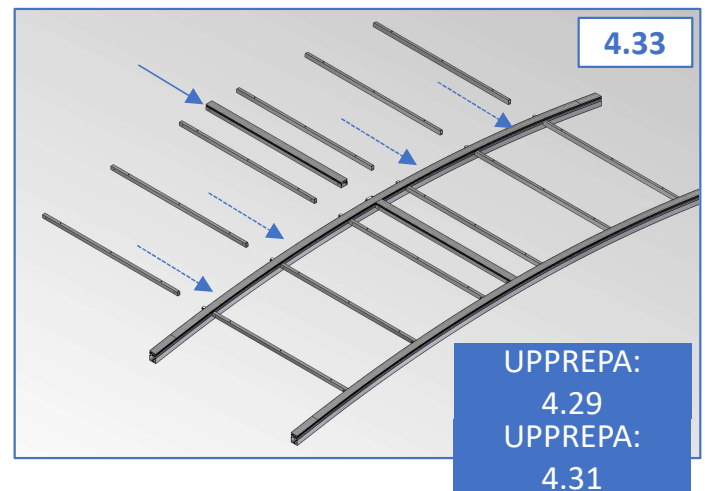
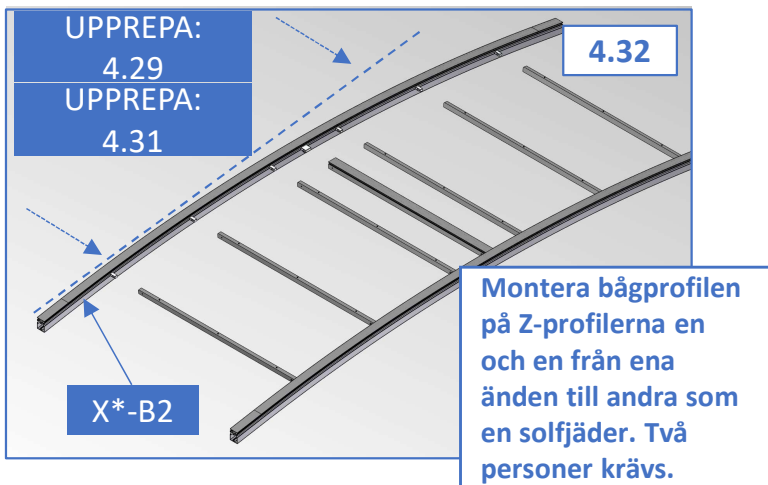
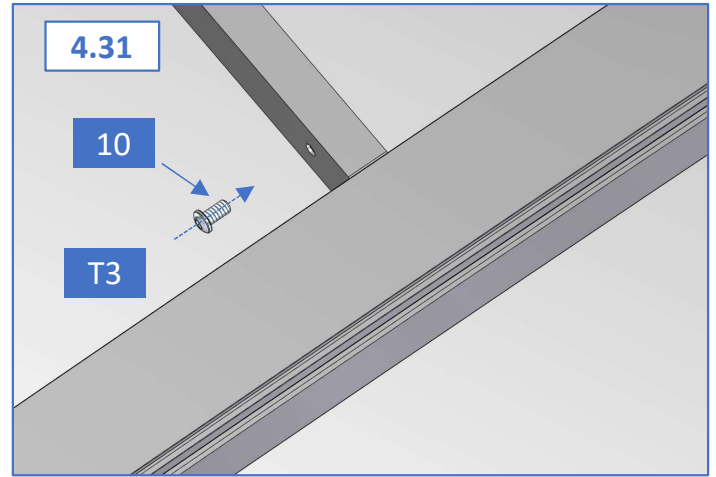
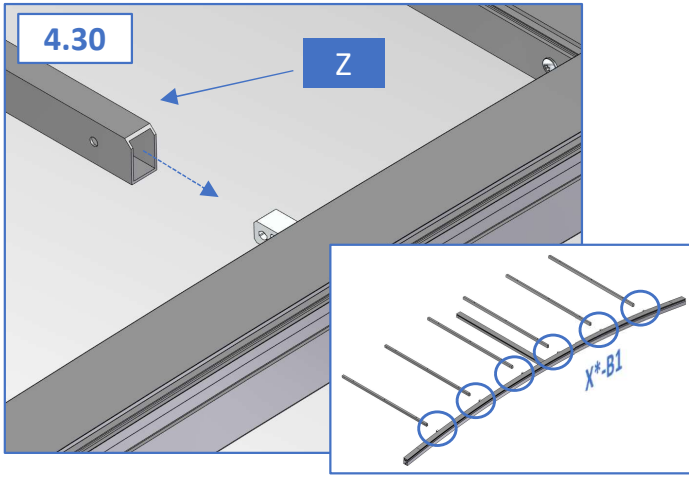

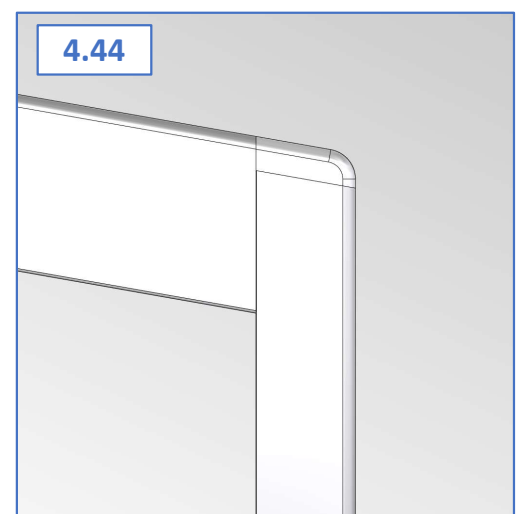
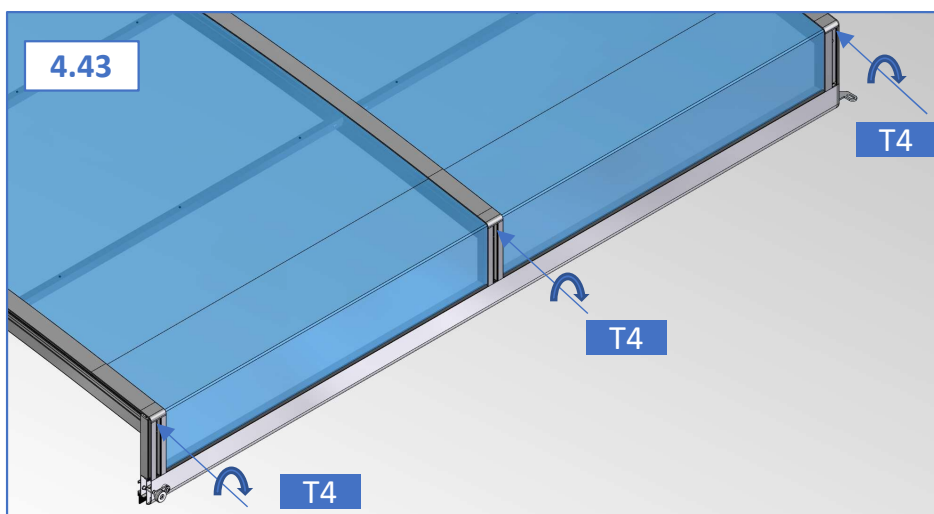
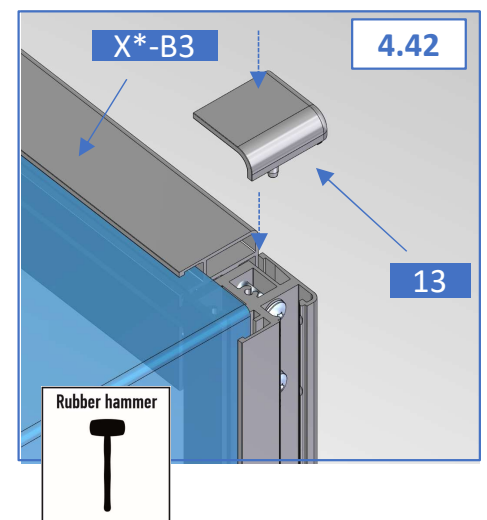
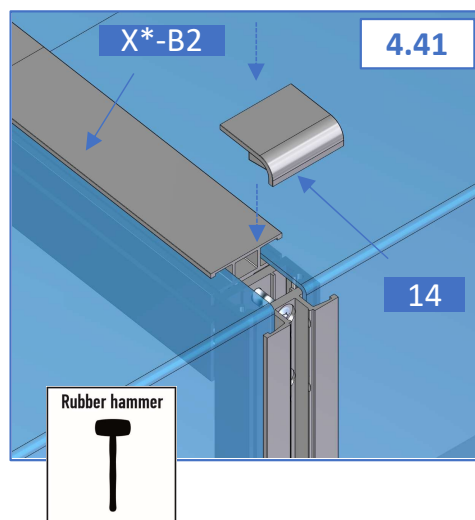
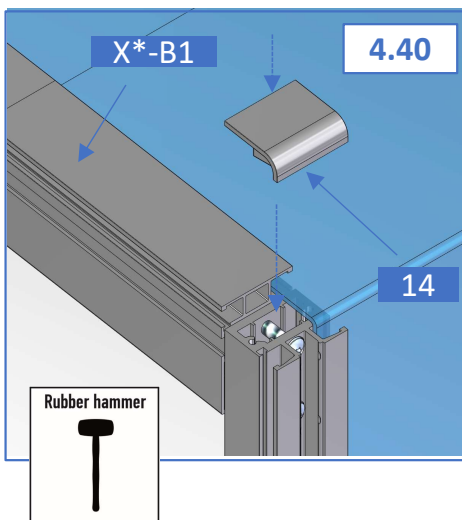
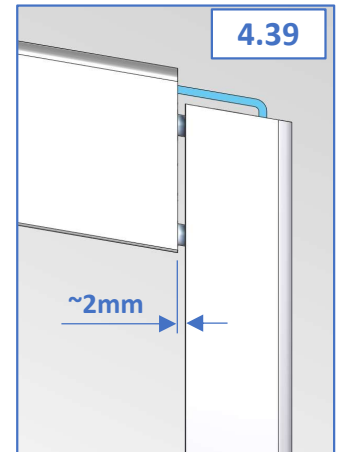
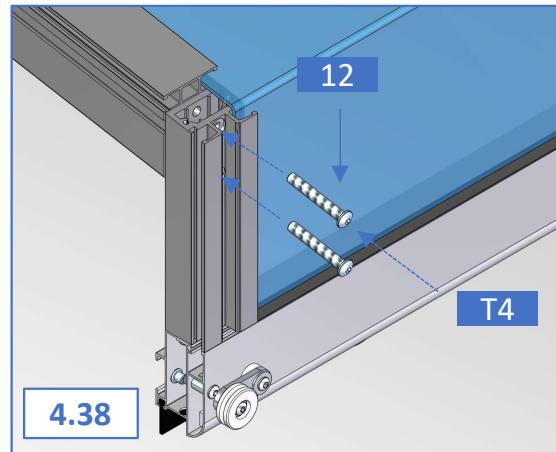
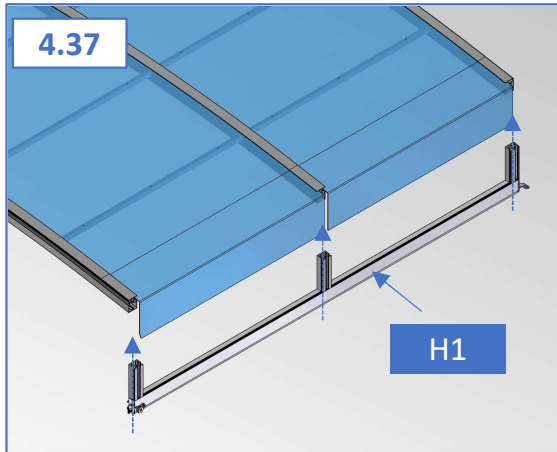

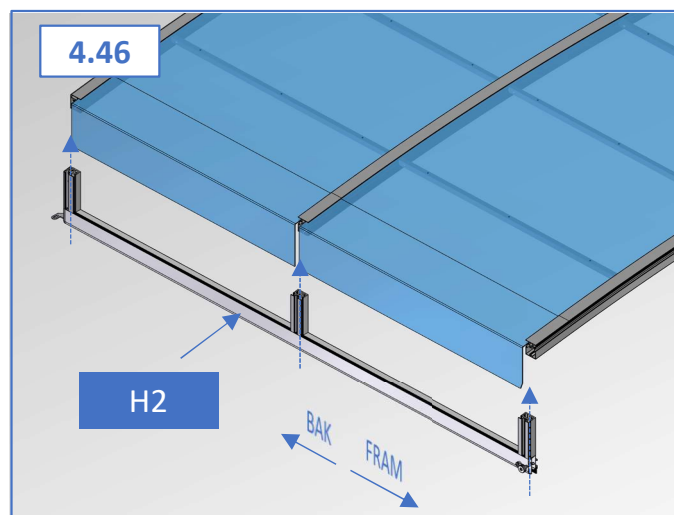
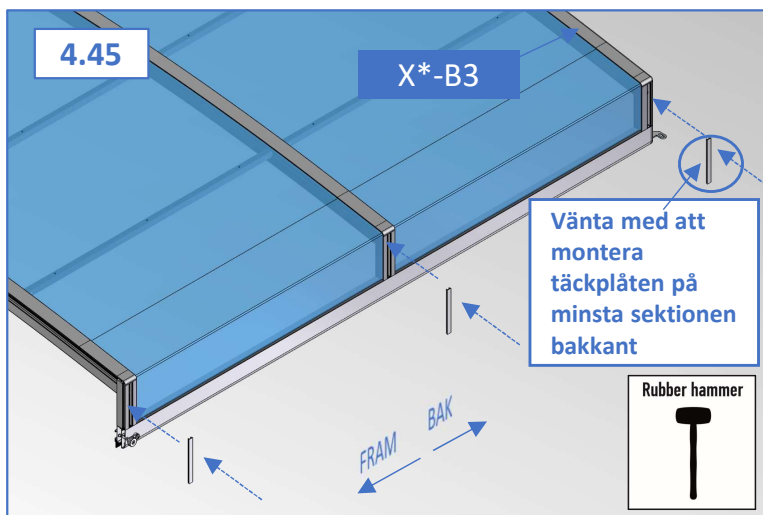

UPPREPA: 4.38 – 4.45

Montera gummilist utsida på samtliga sektioner enl bild 3.54

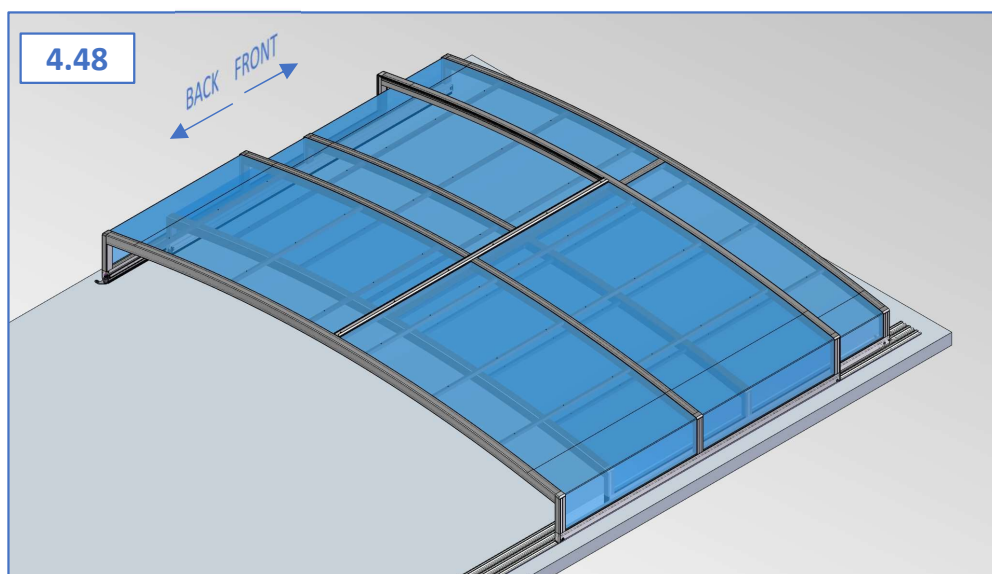
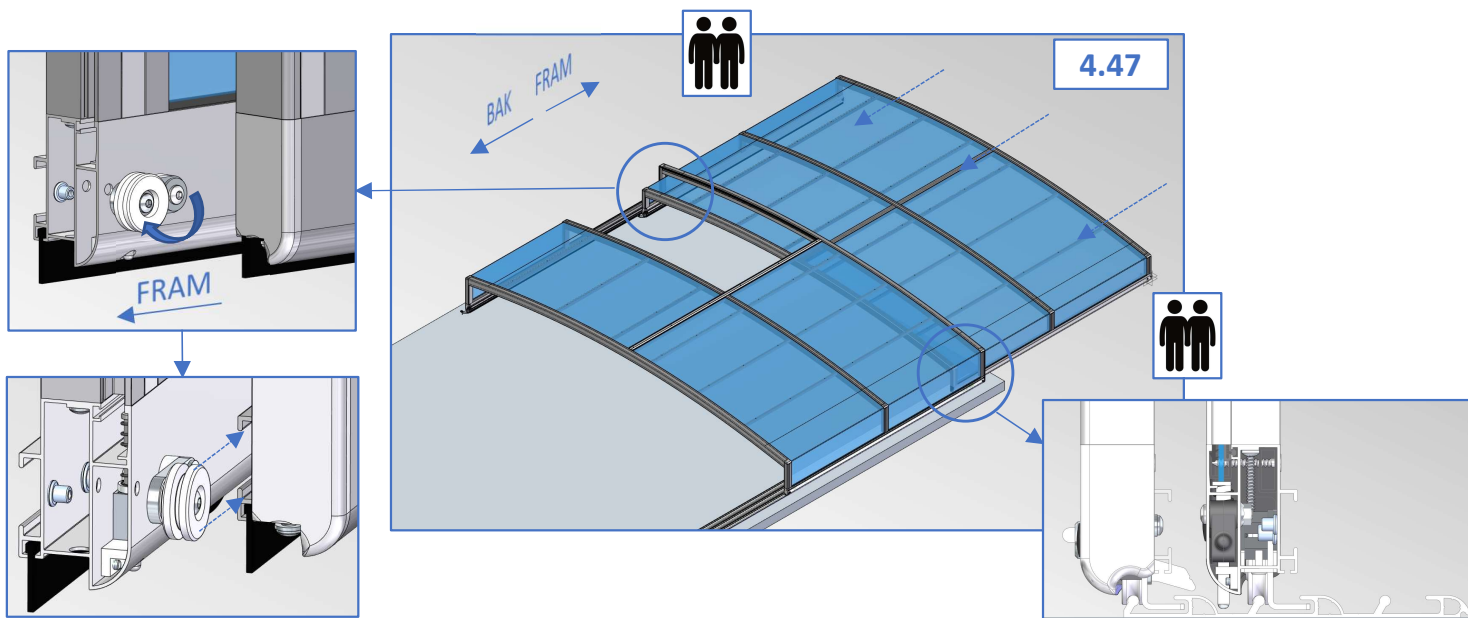

Montera samtliga mellansektioner enligt 4.01 – 4.47

Observera följande punkter vid montering av den minsta sektionen 4.02, 4.07, 4.14, 4.45.



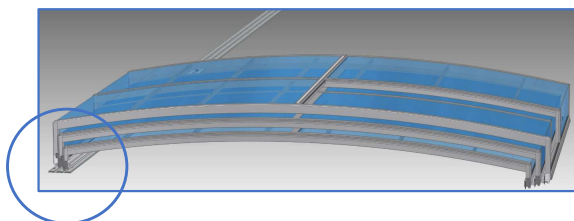

Markerade hål ska borras med  
4,1 borr enl. mall.  
Mallen kan tas bort efteråt.

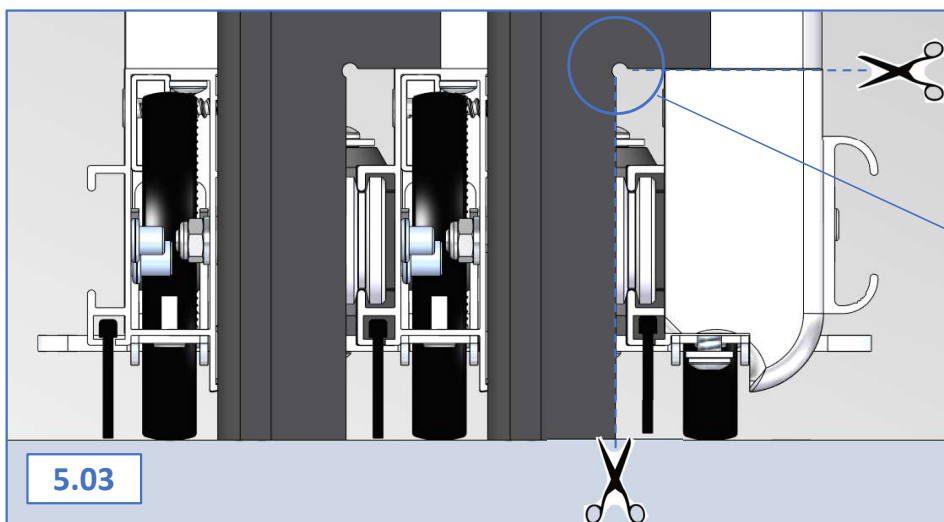
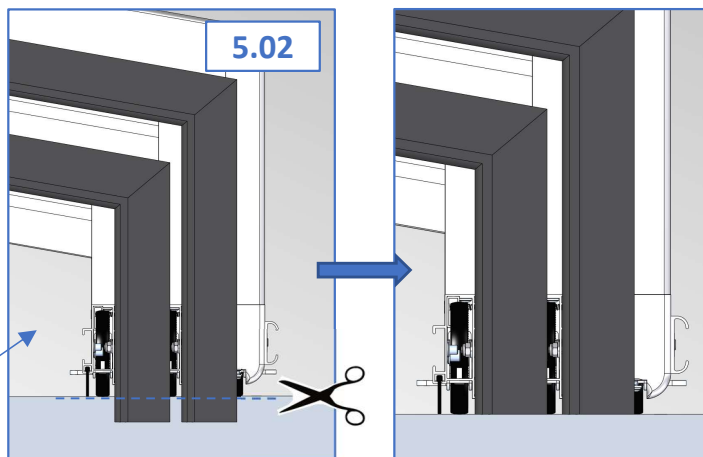
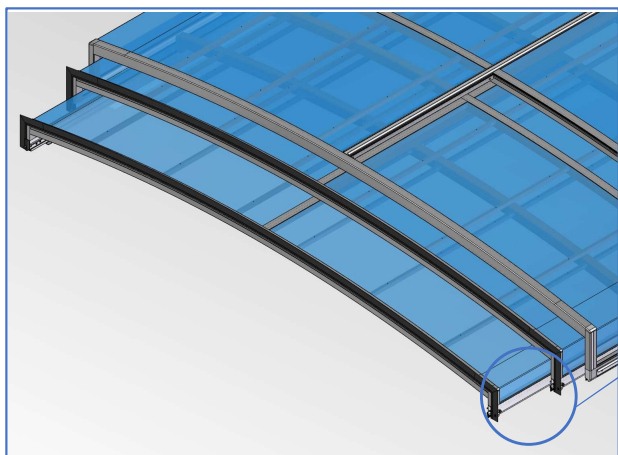
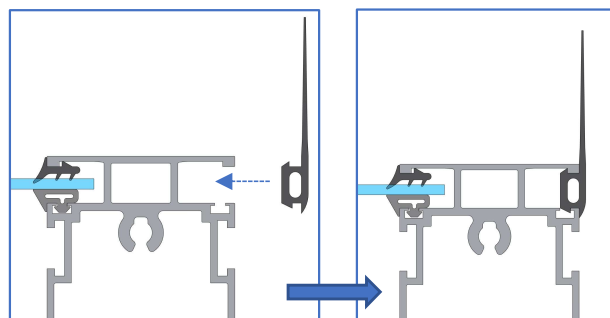
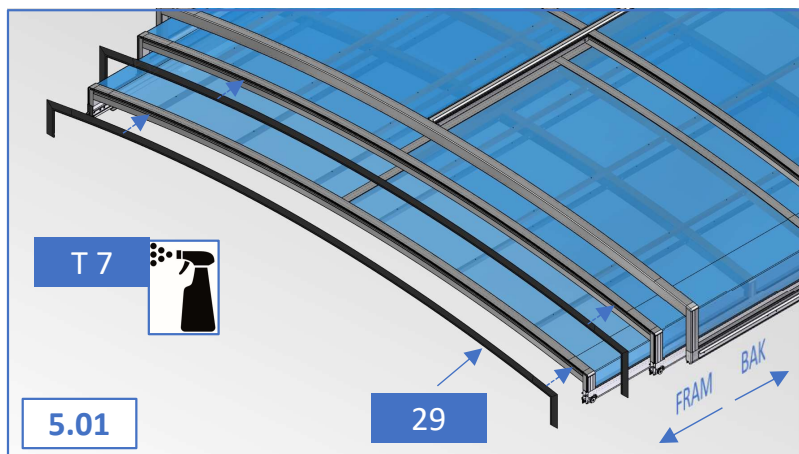
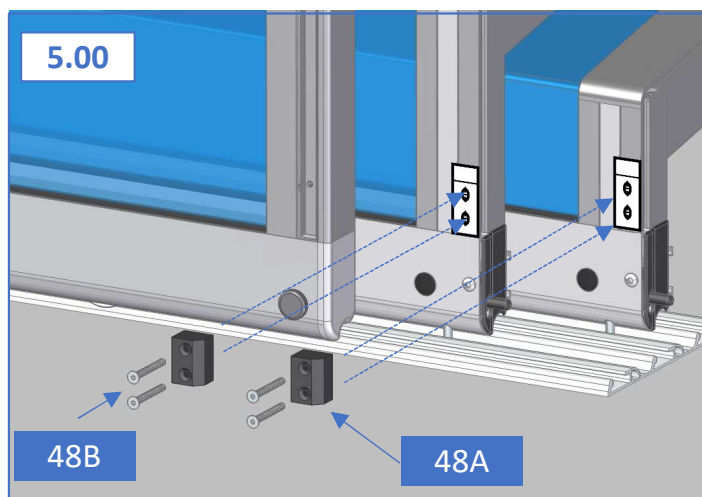

Gör en liten  
rundning i hörnan  
för att minska  
gummits slitage.

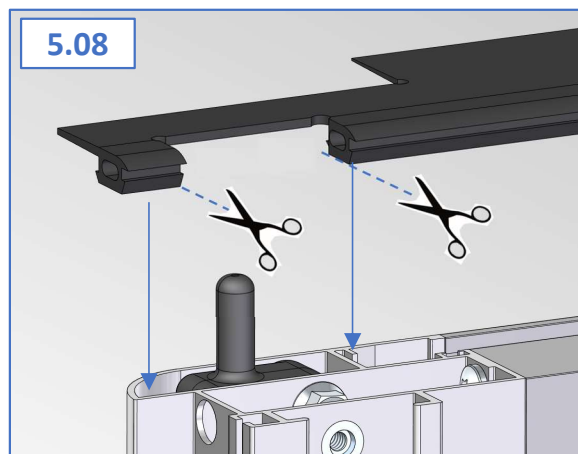
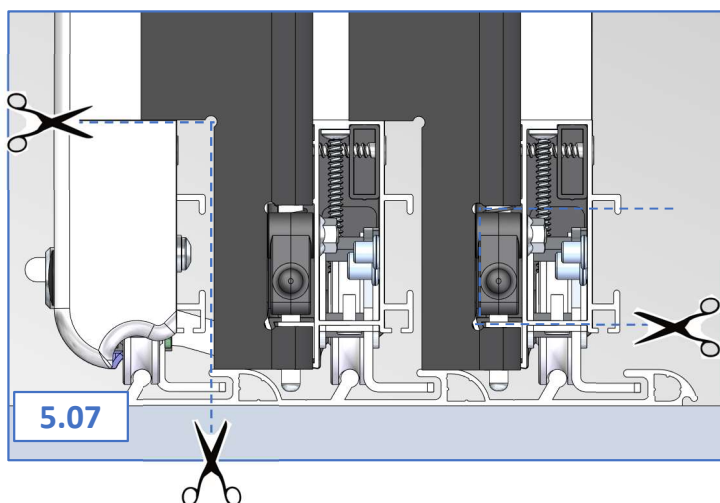
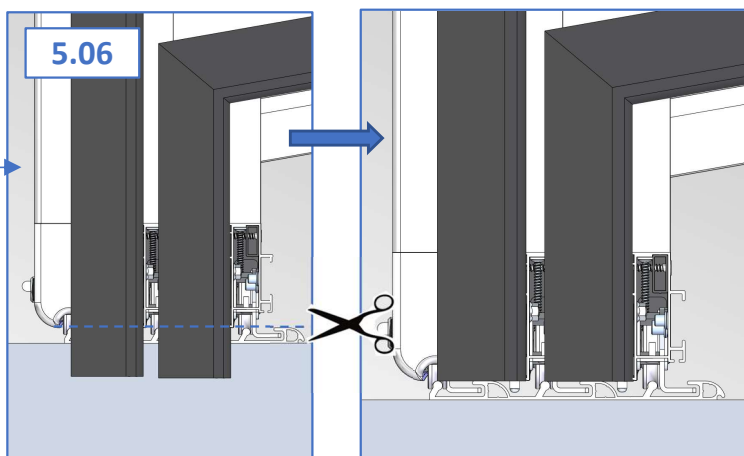
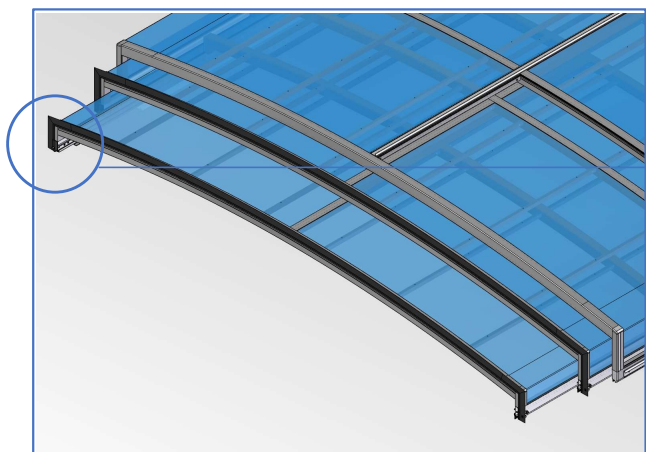
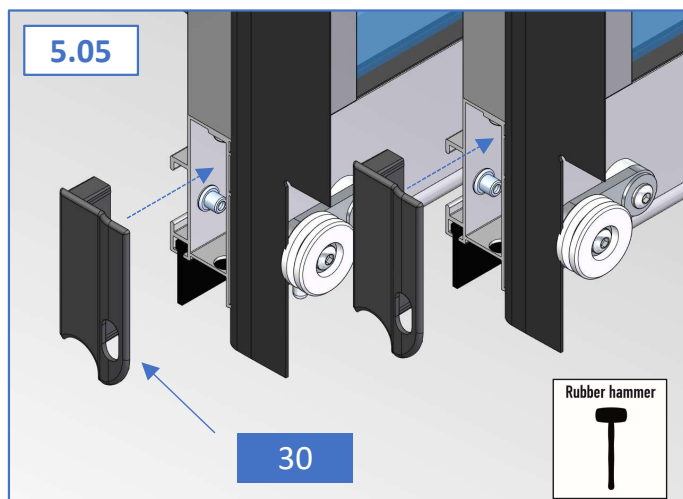
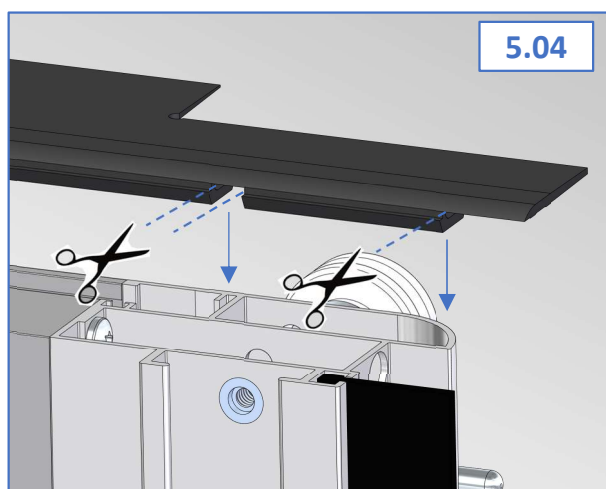

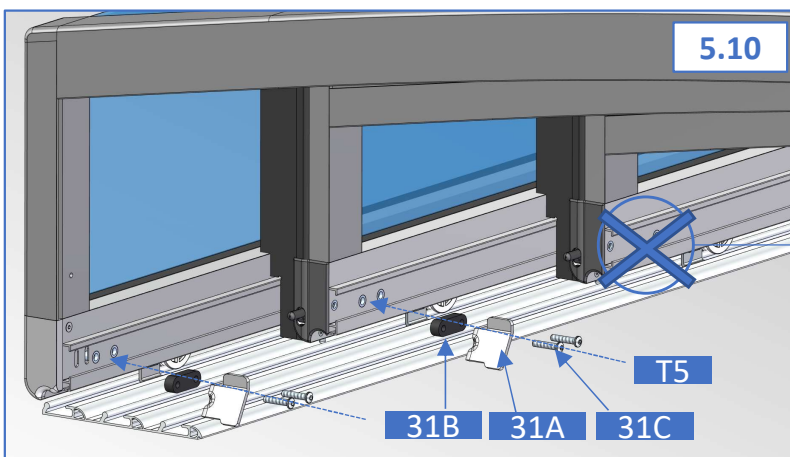
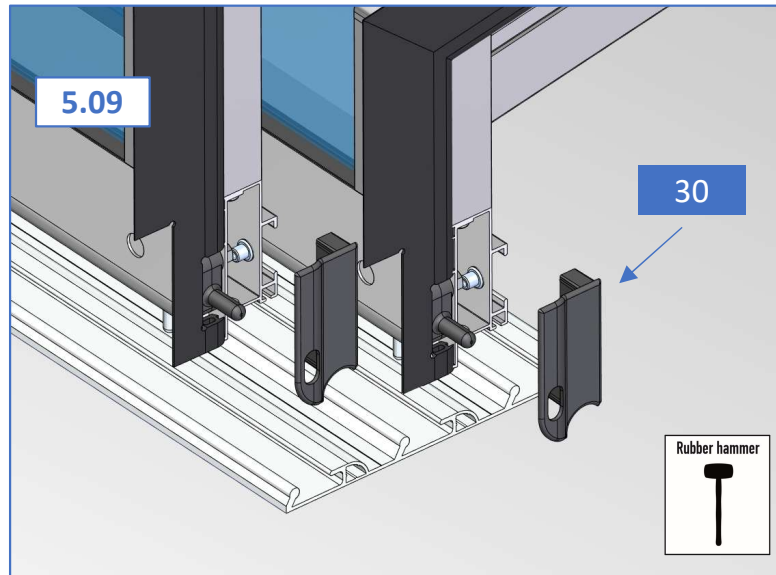

Låsbeslag (Nr.31.) ska inte monteras på minsta sektionen

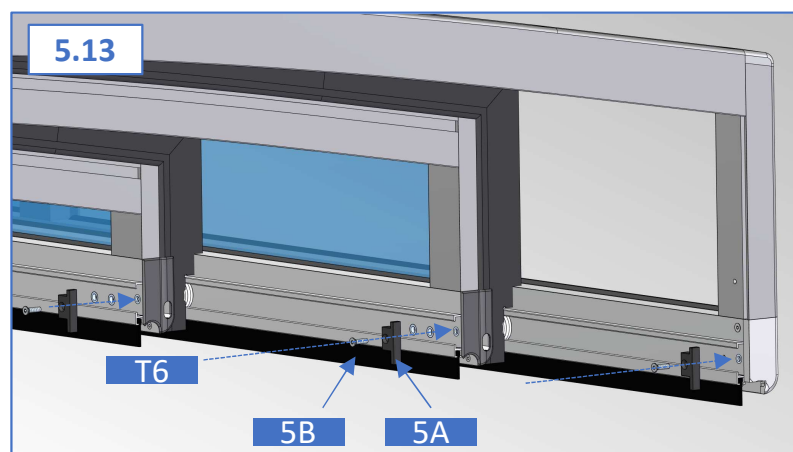
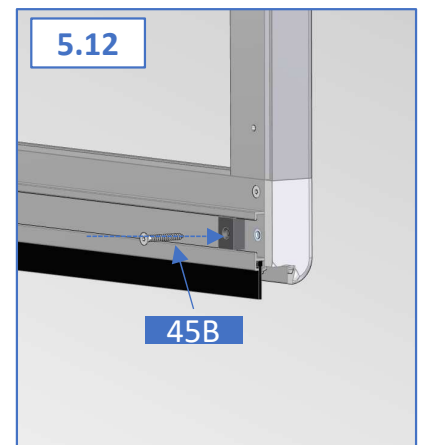
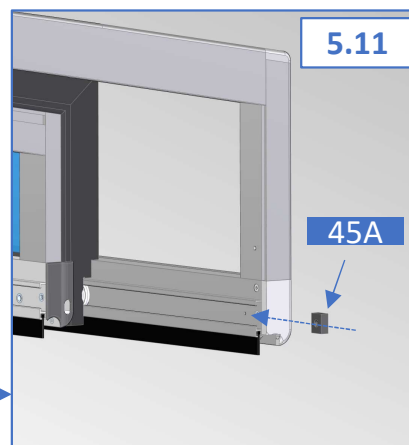
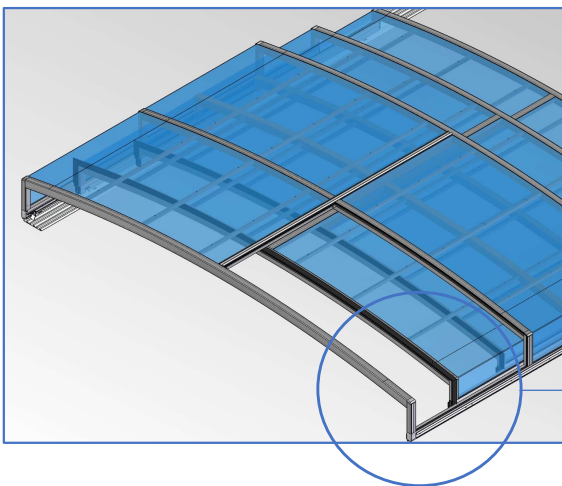



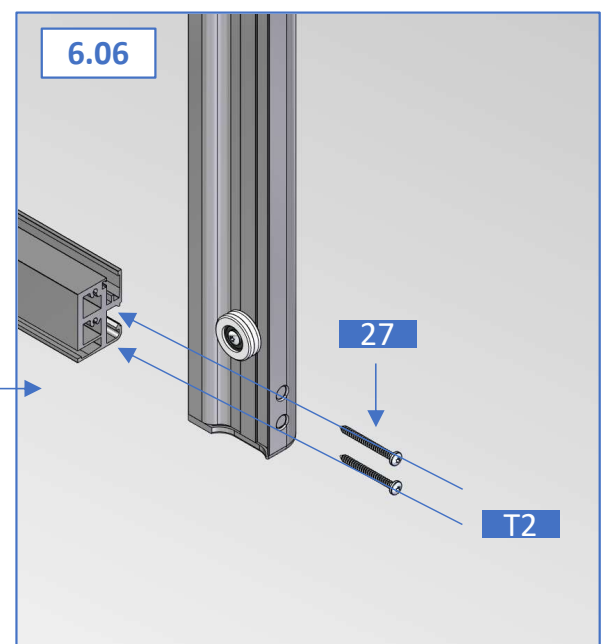
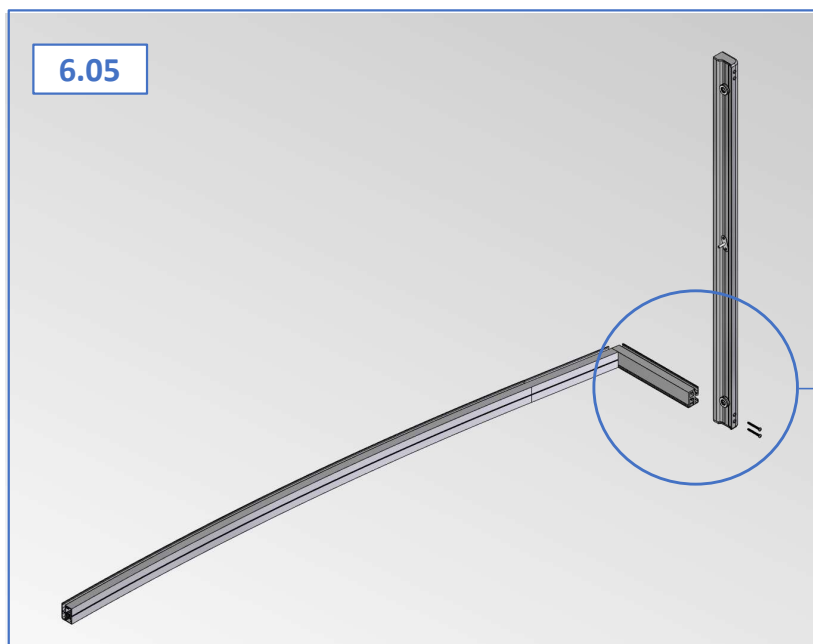
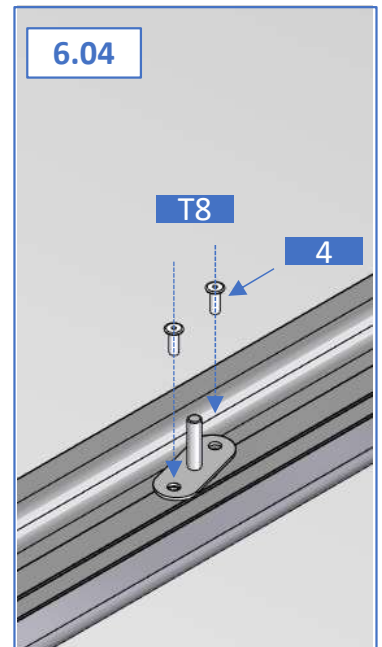
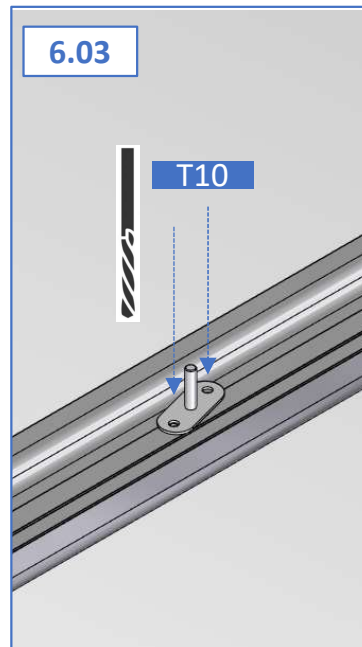
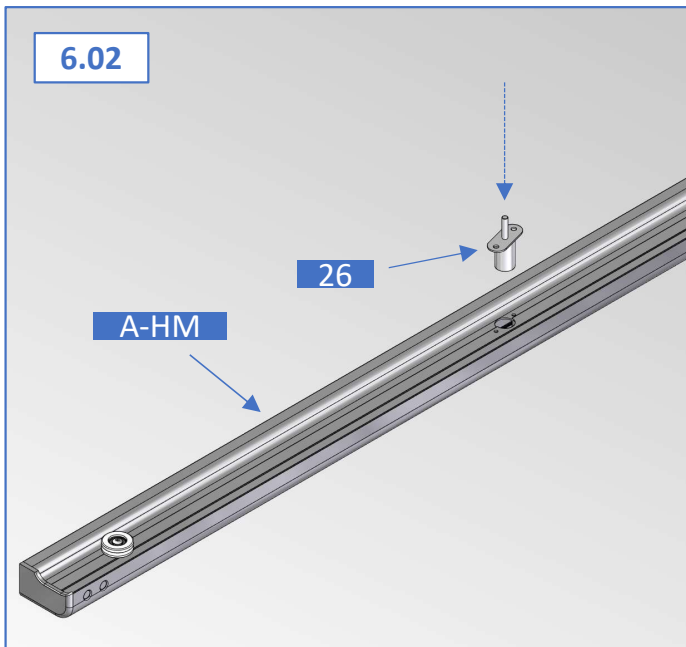
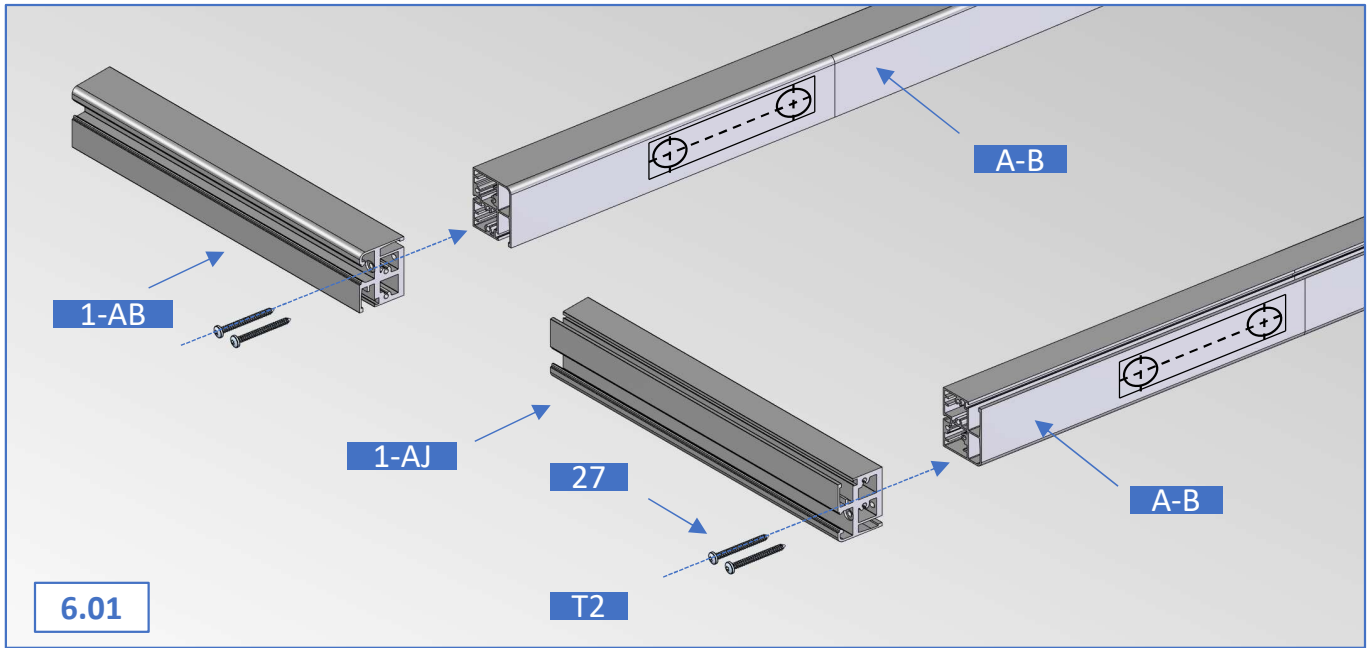

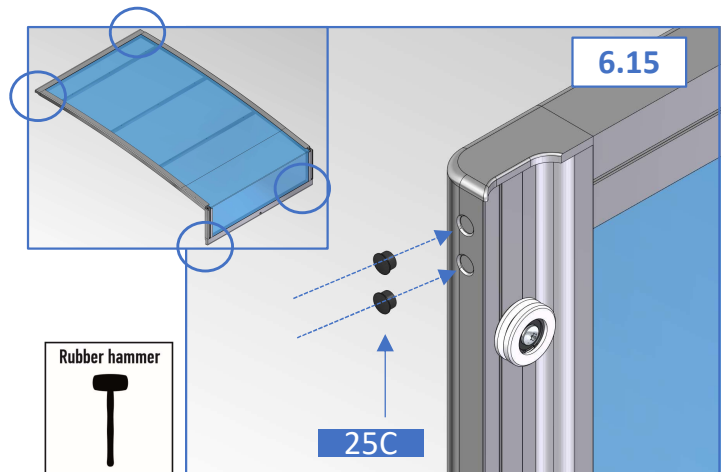
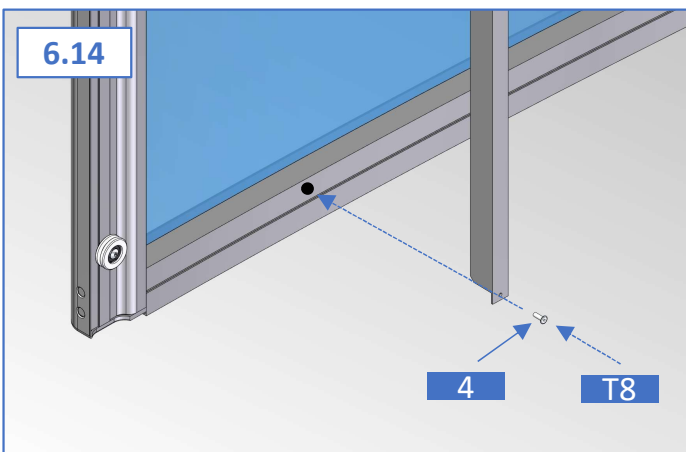
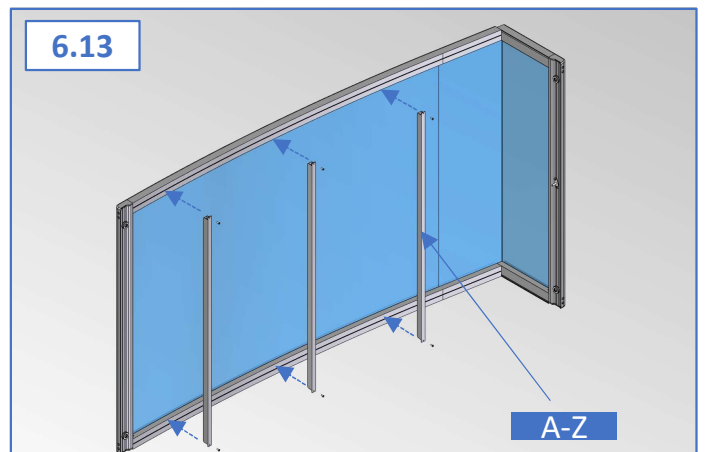
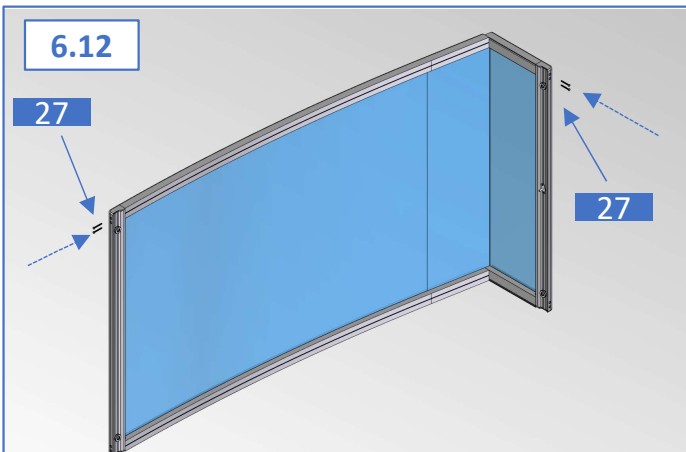
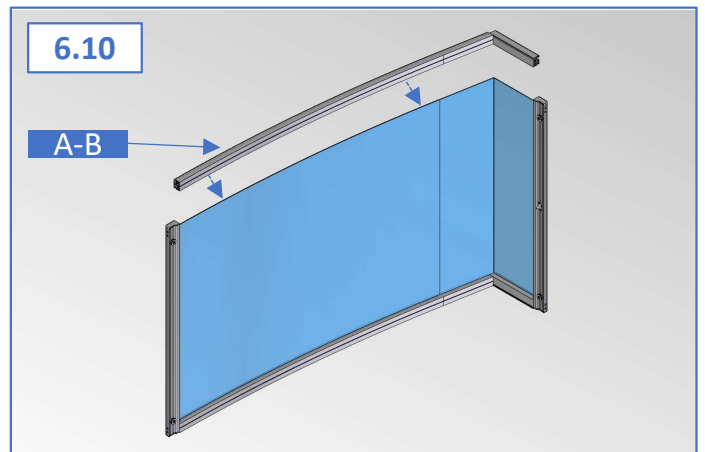
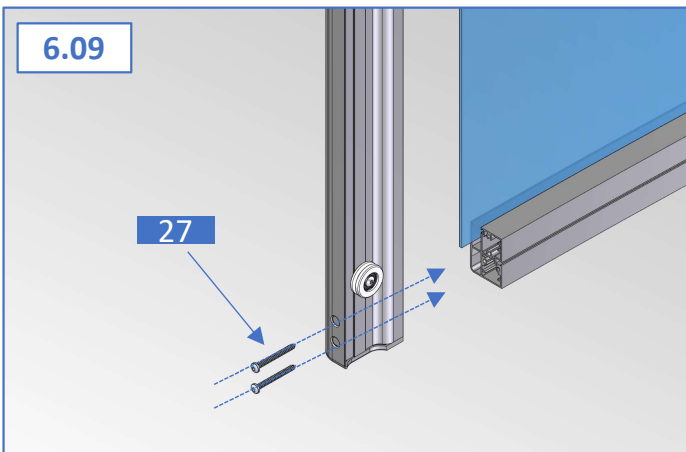
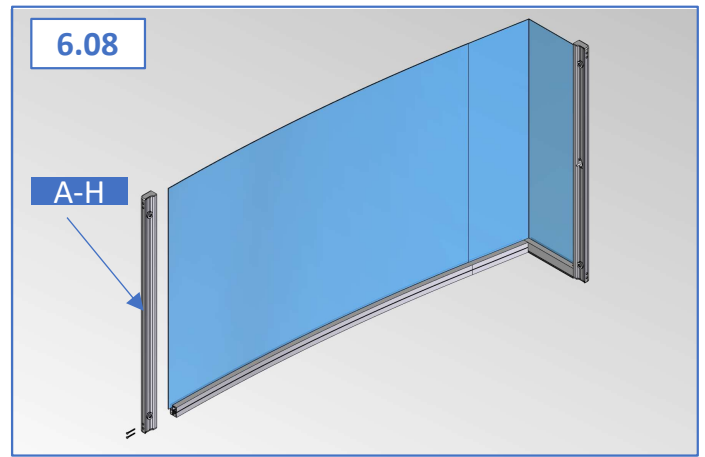
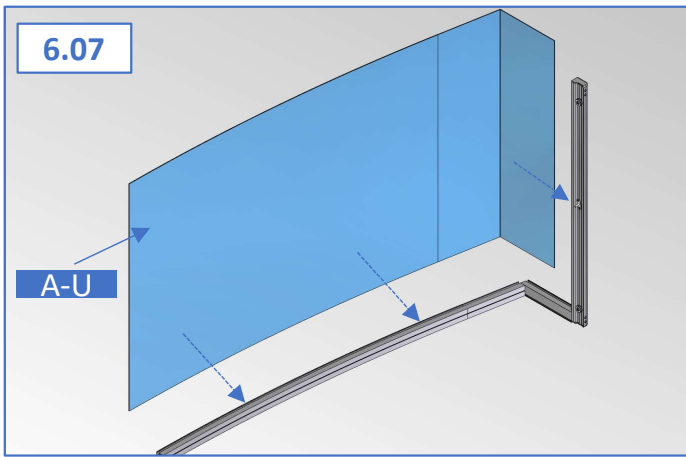

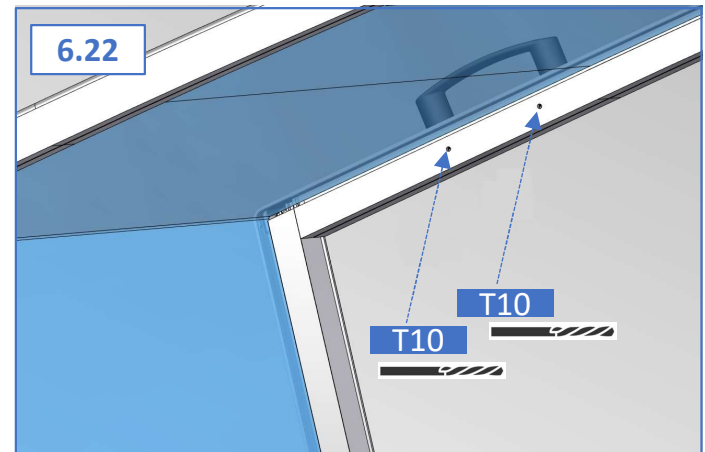
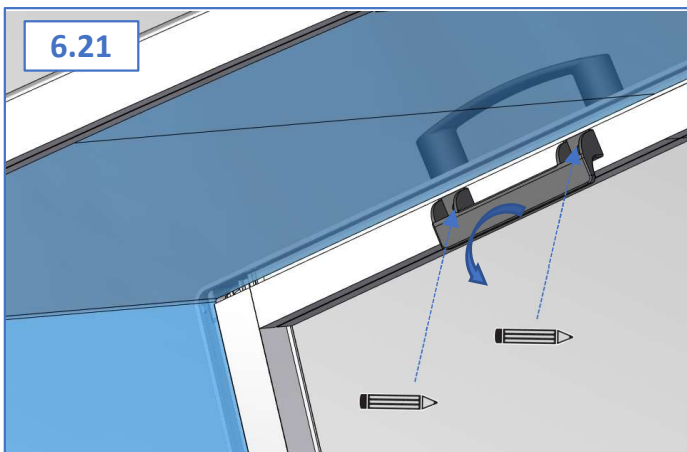
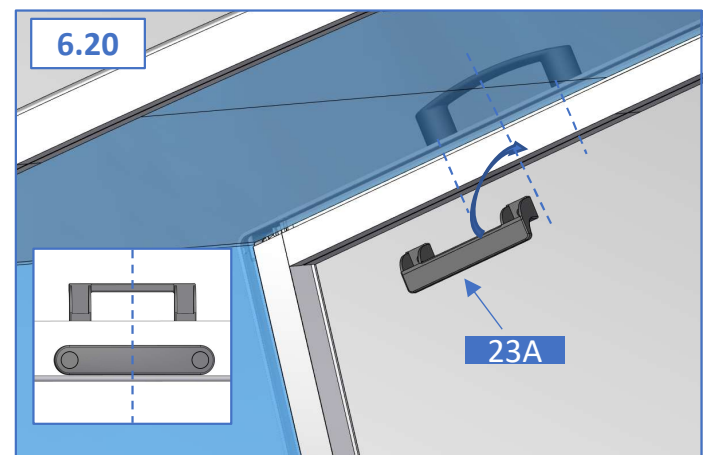
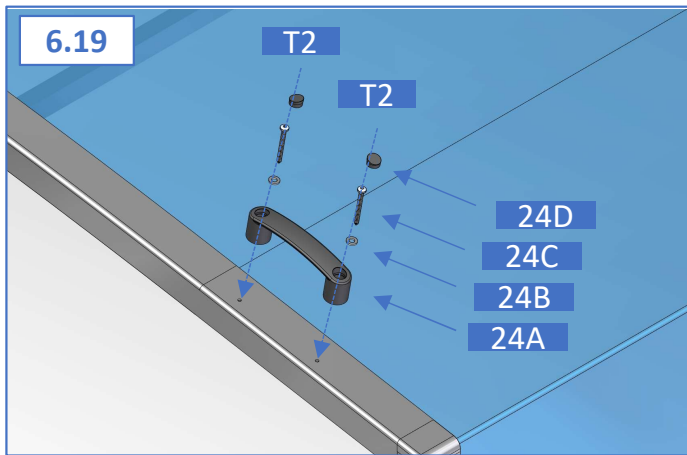
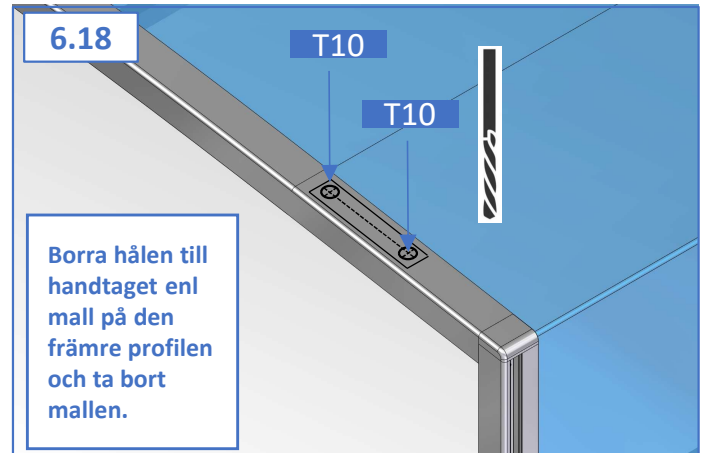
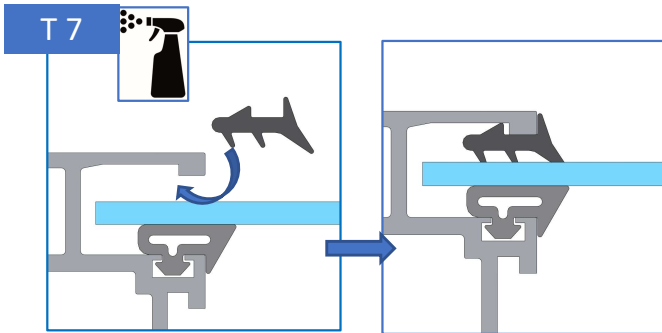
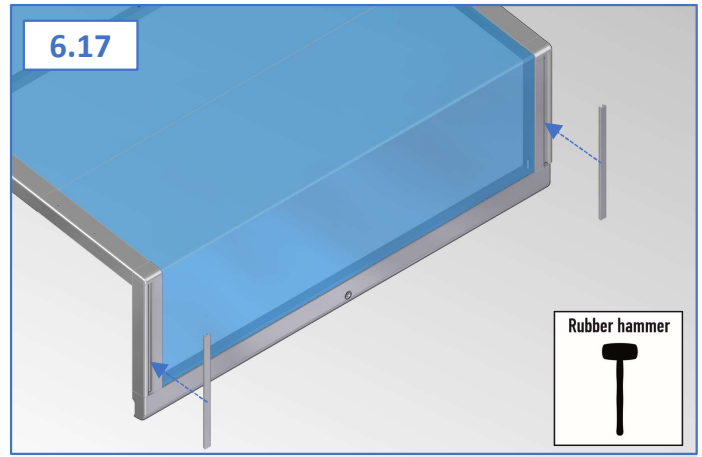
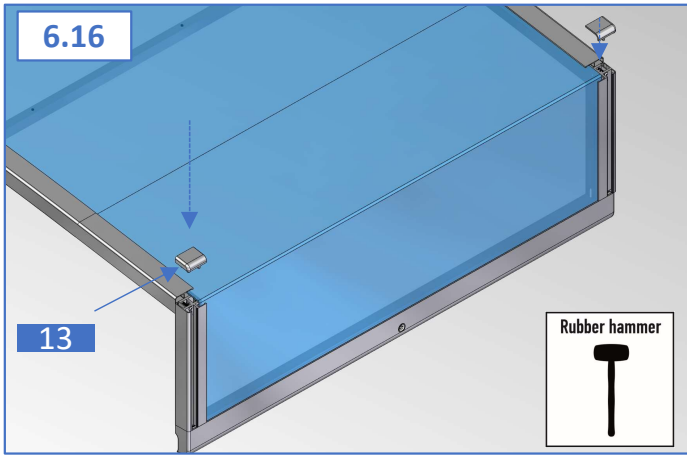





Vid montering av dörrlisten (nr 28) börja i hörnan med hörnändstycken (nr 13-14) klipp listen ca 10 mm längre och montera listen.

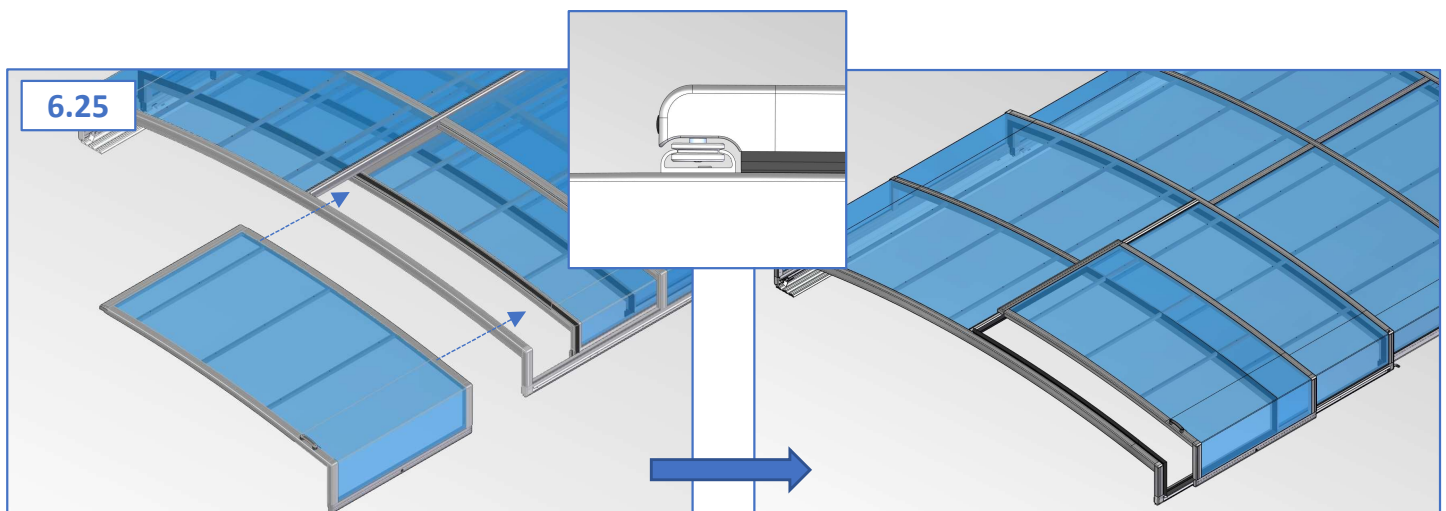
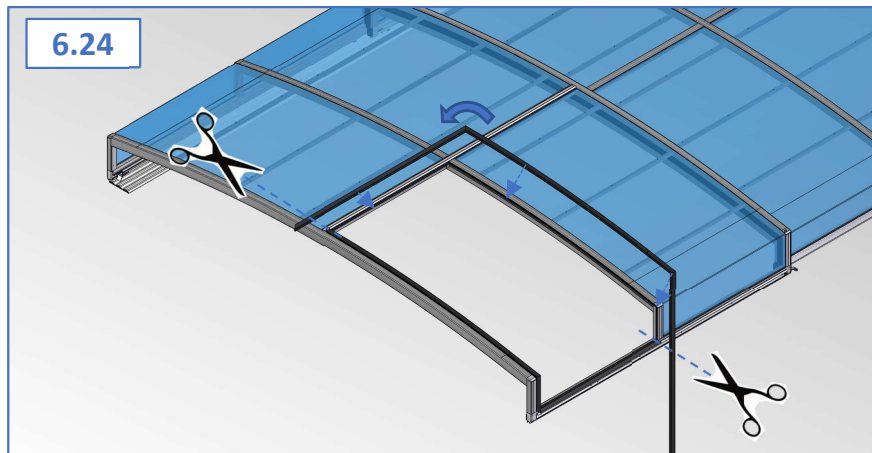
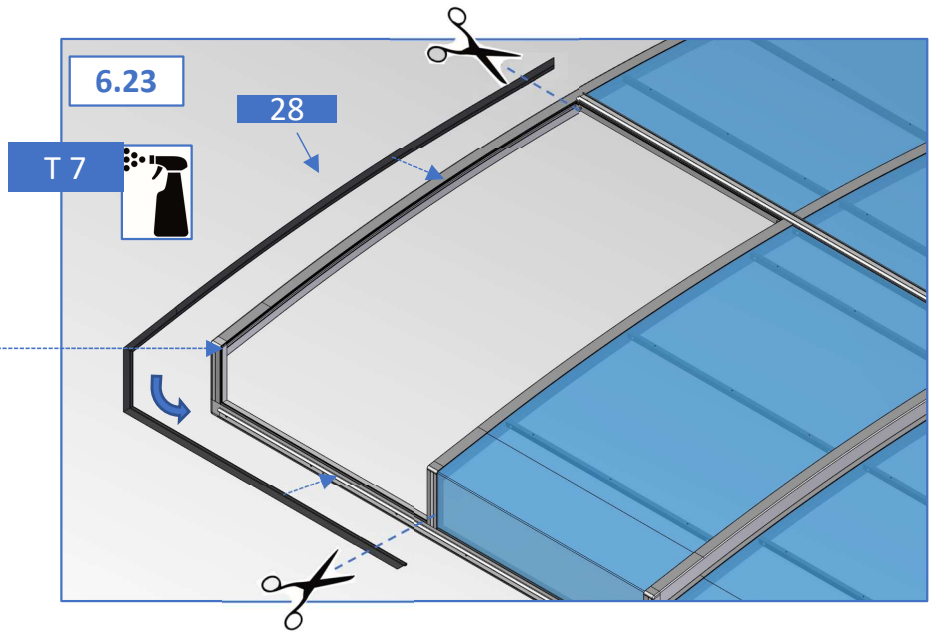
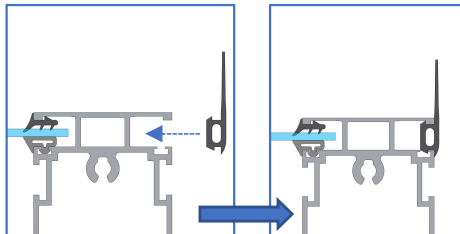

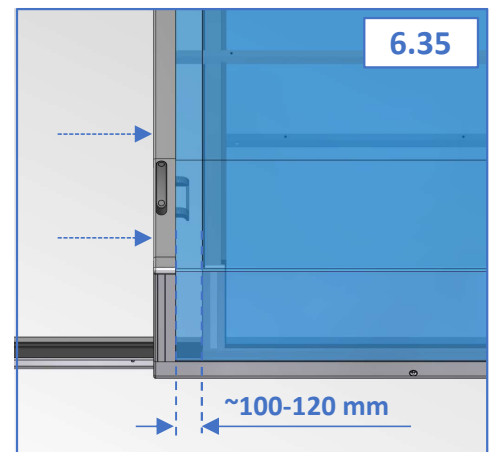
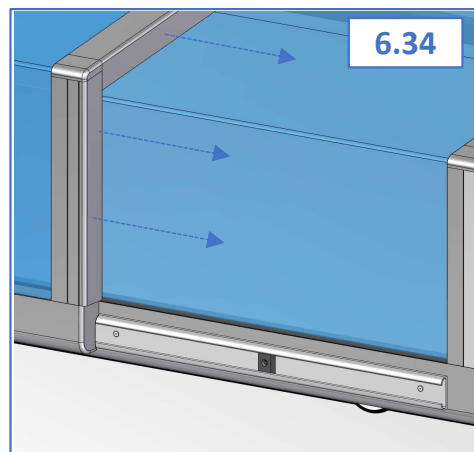
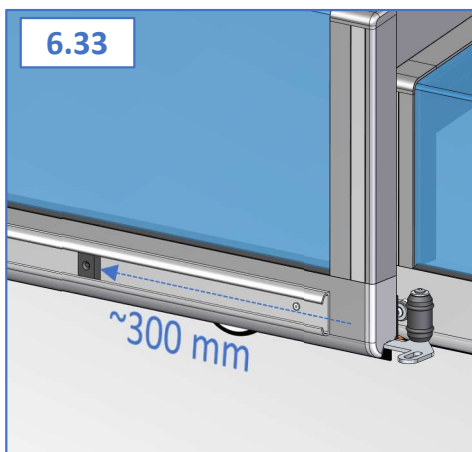
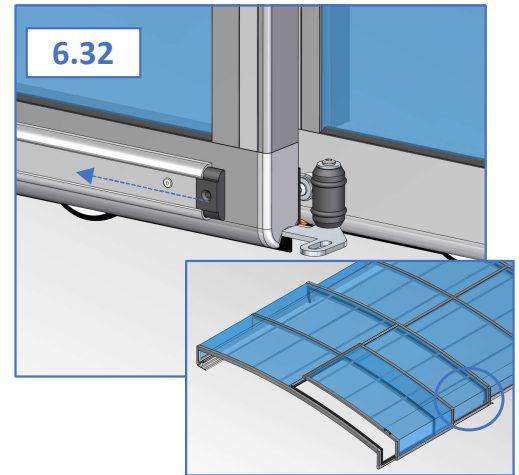
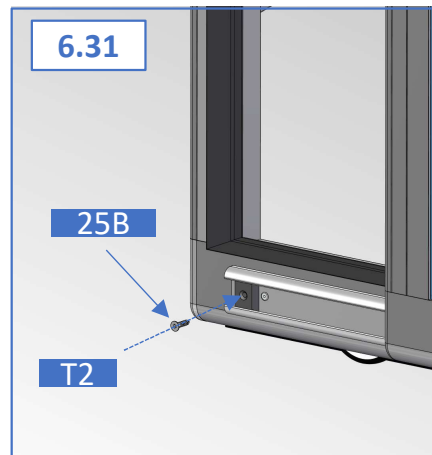
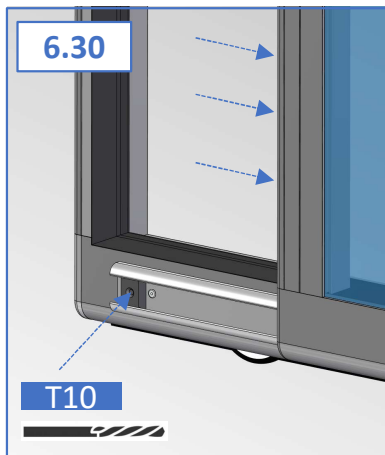
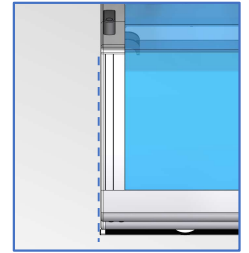
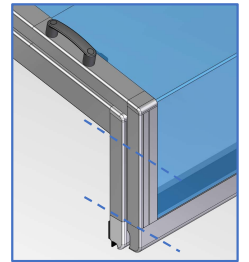
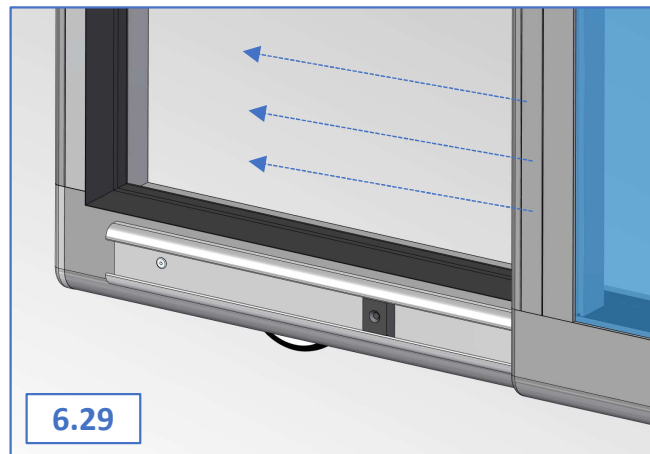
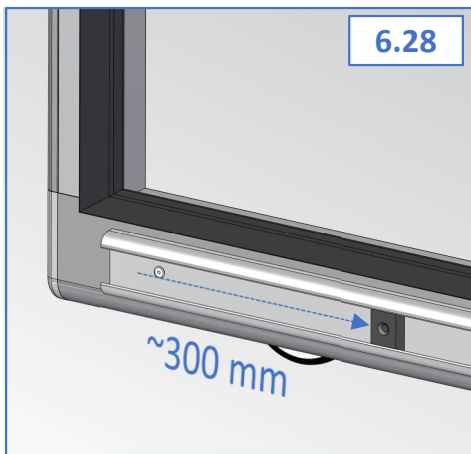
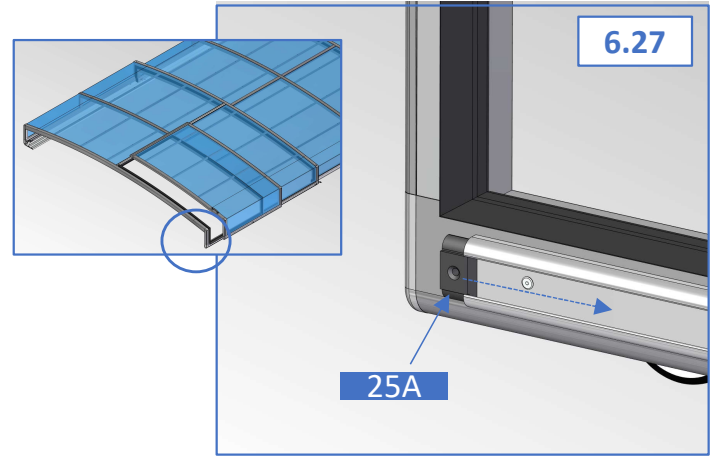
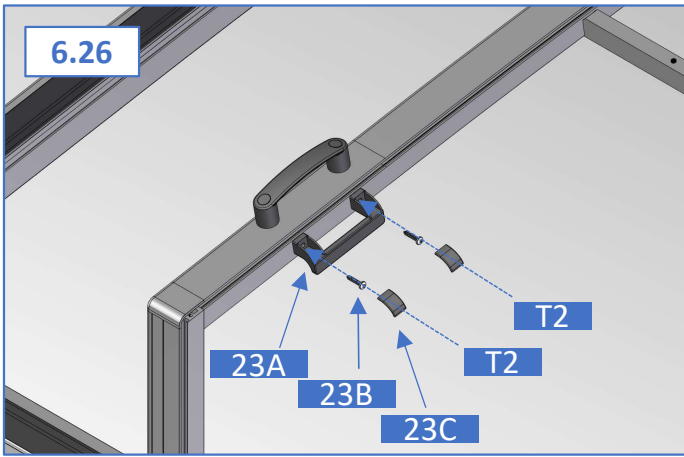

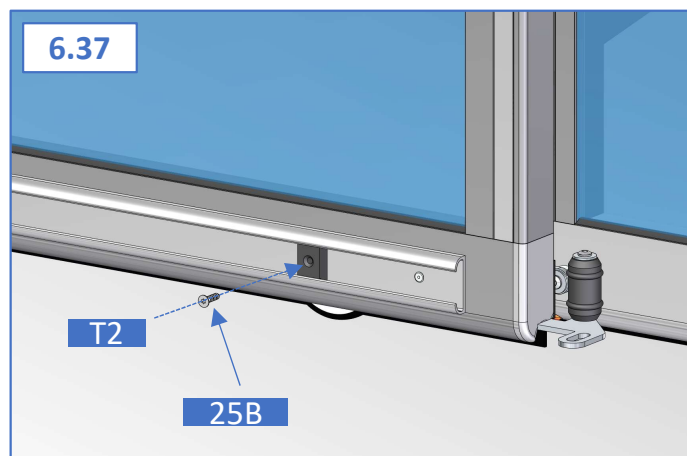
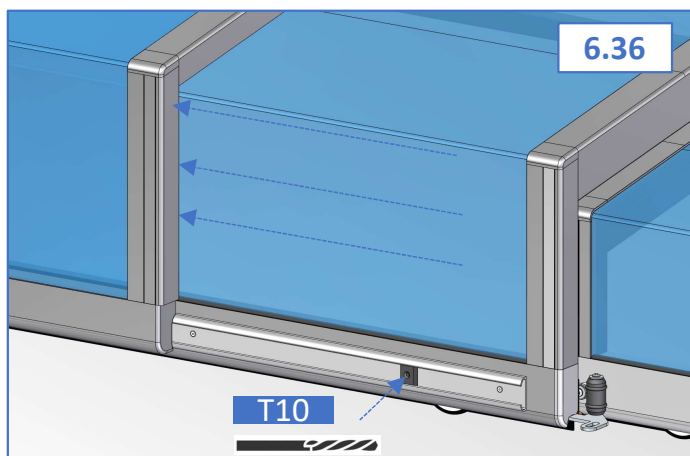

## FRONTGAVEL:

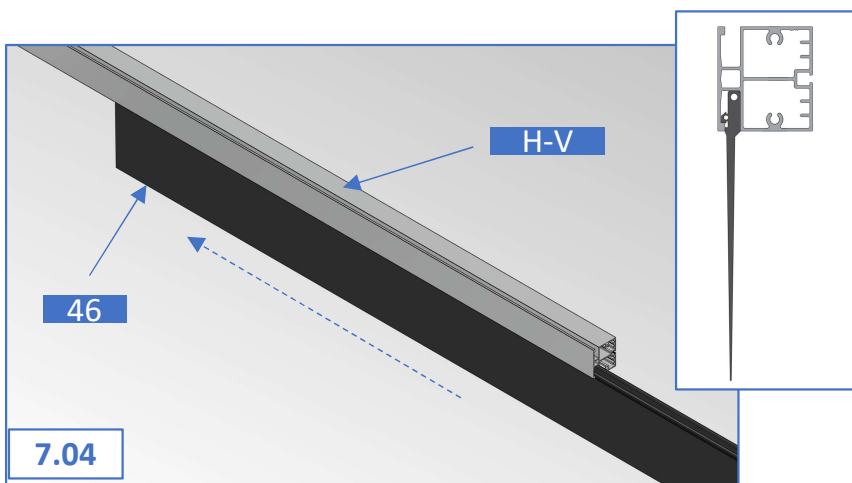
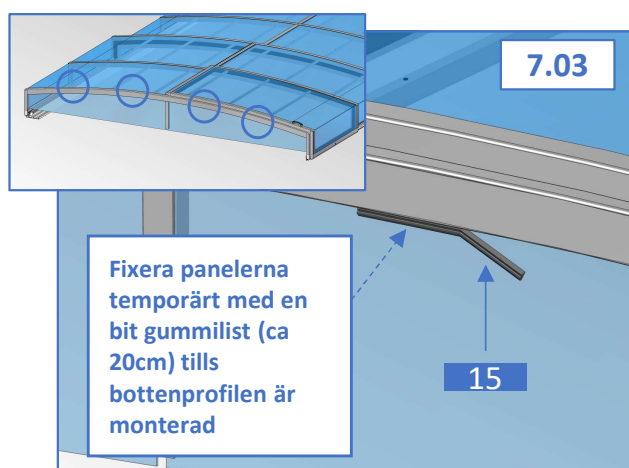
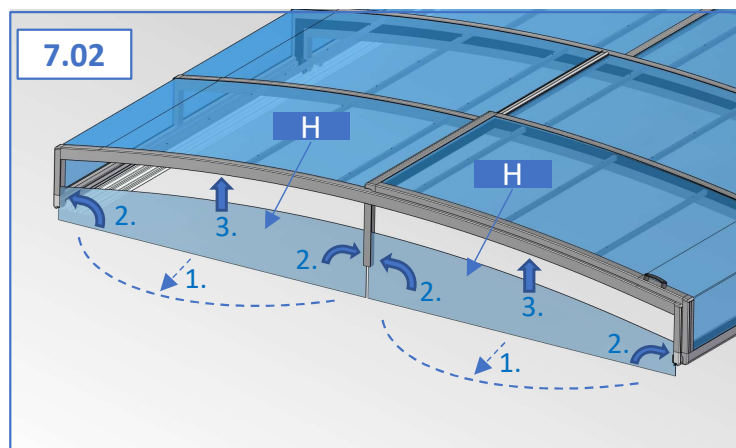
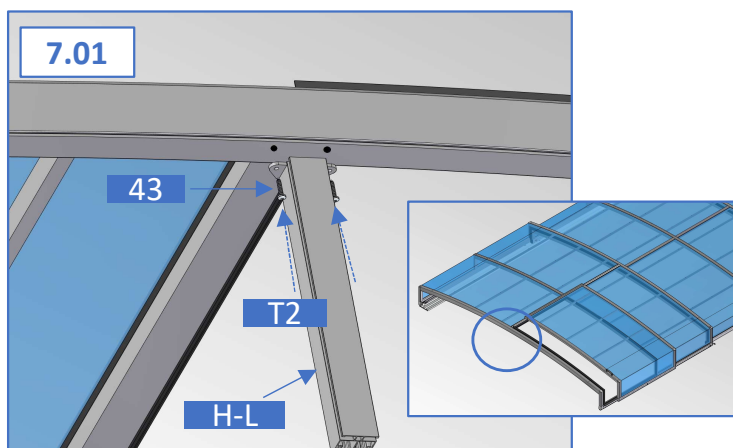



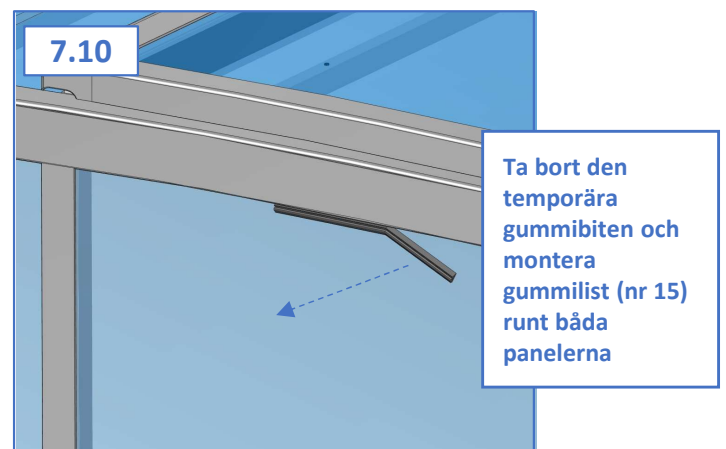
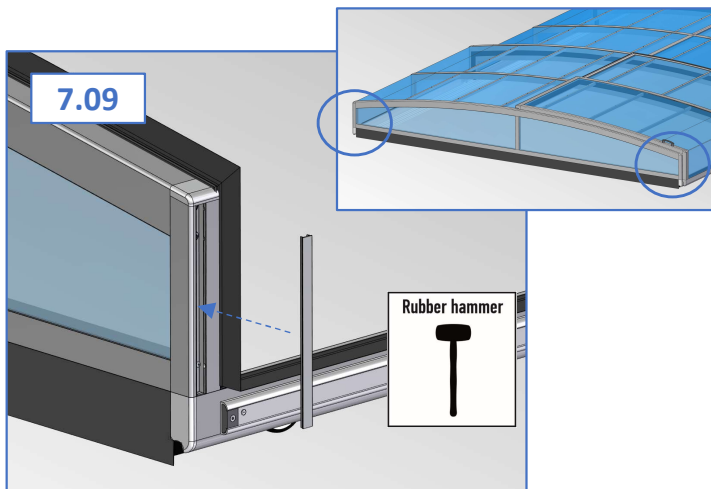
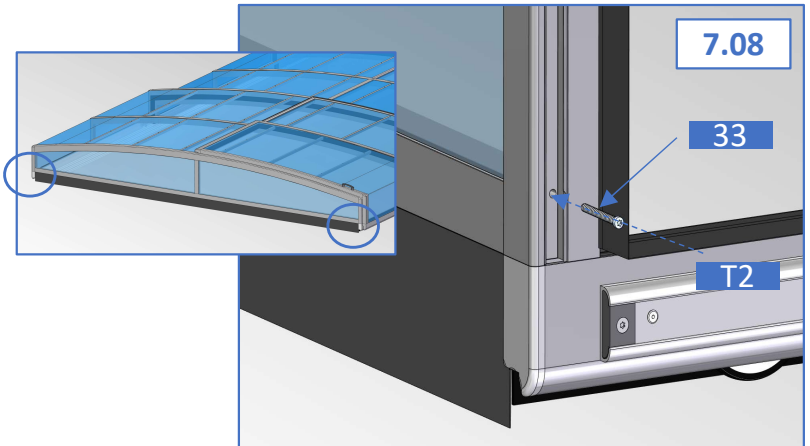
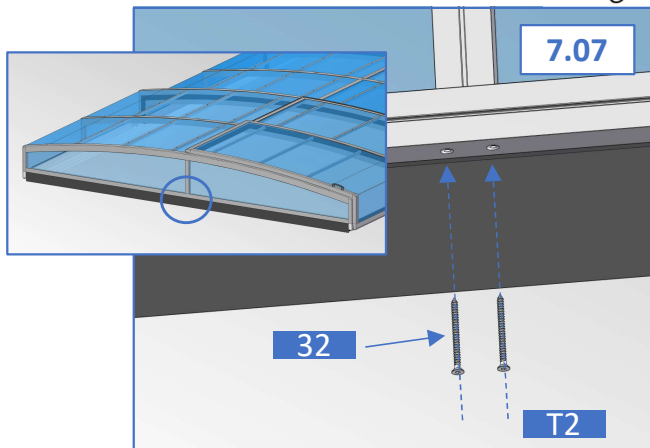
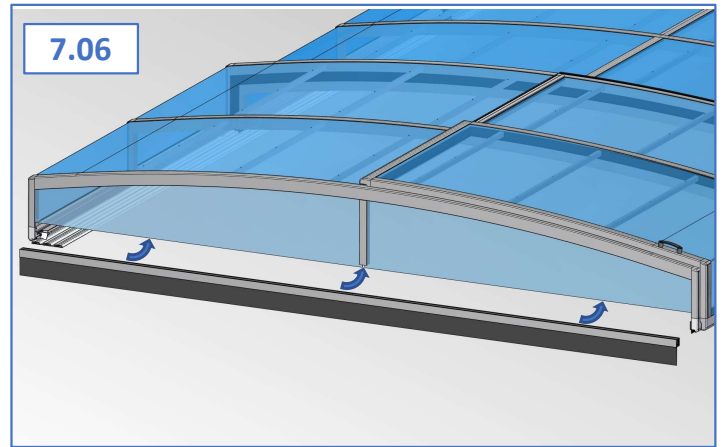
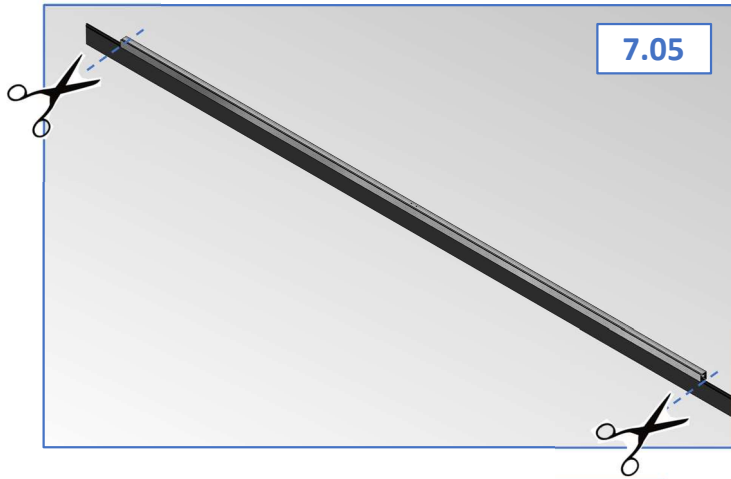

## BAKGAVEL:

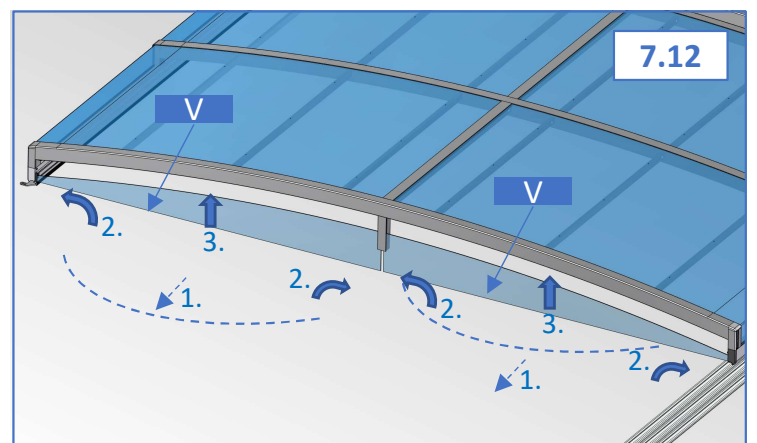
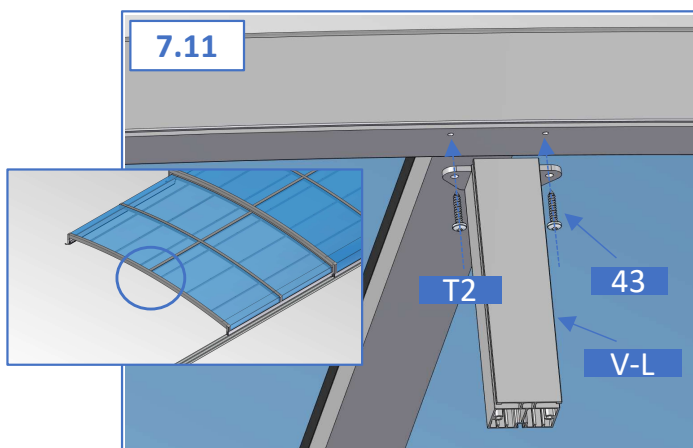

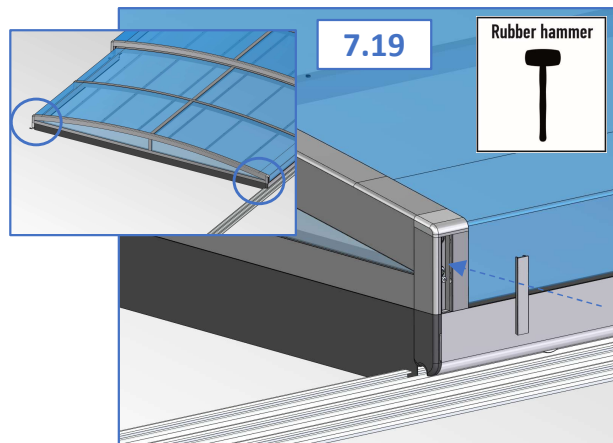
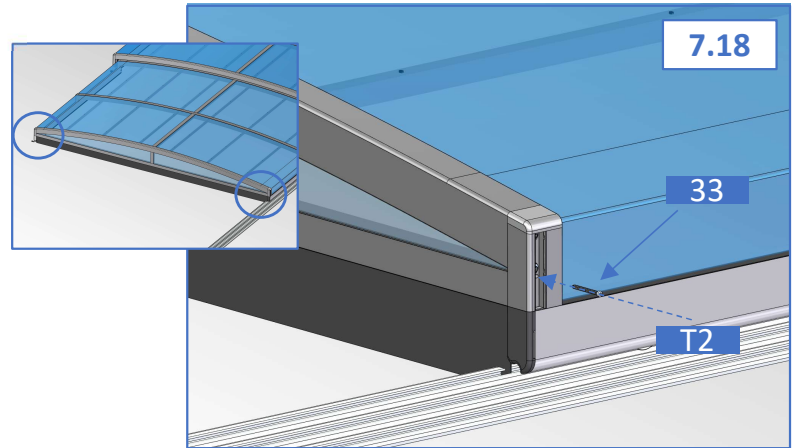
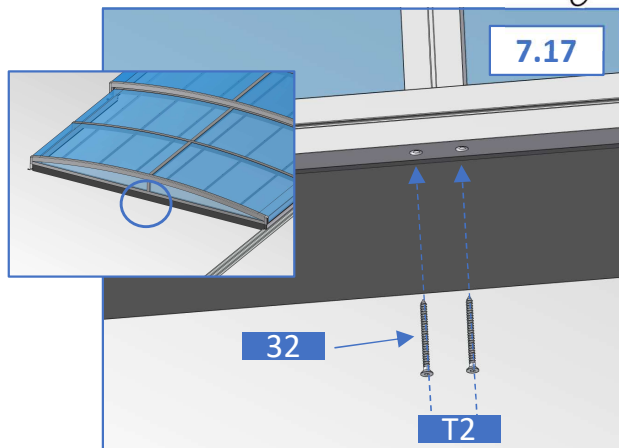
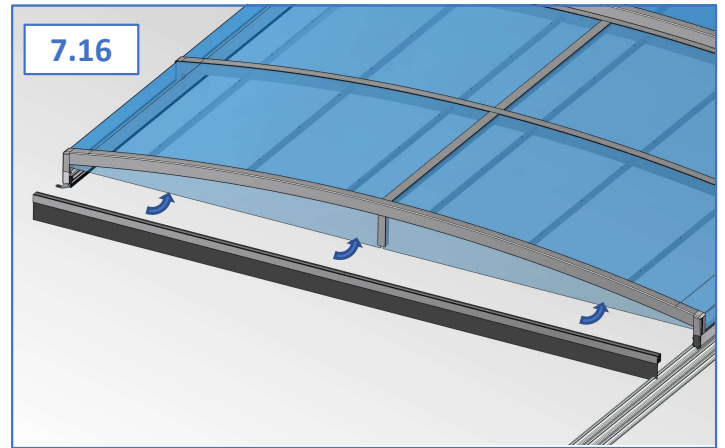
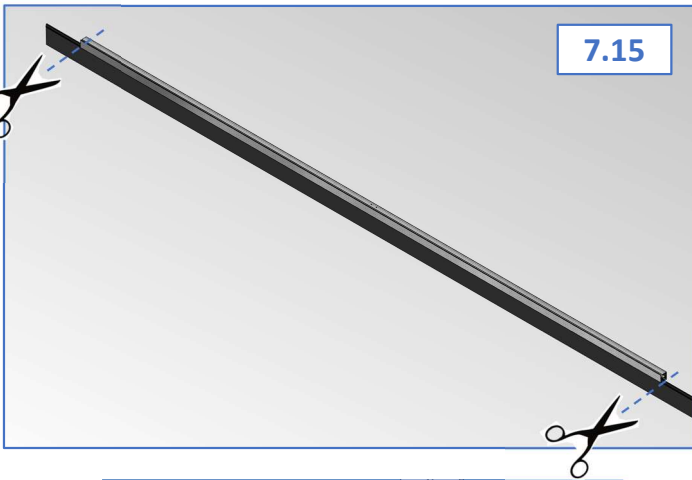
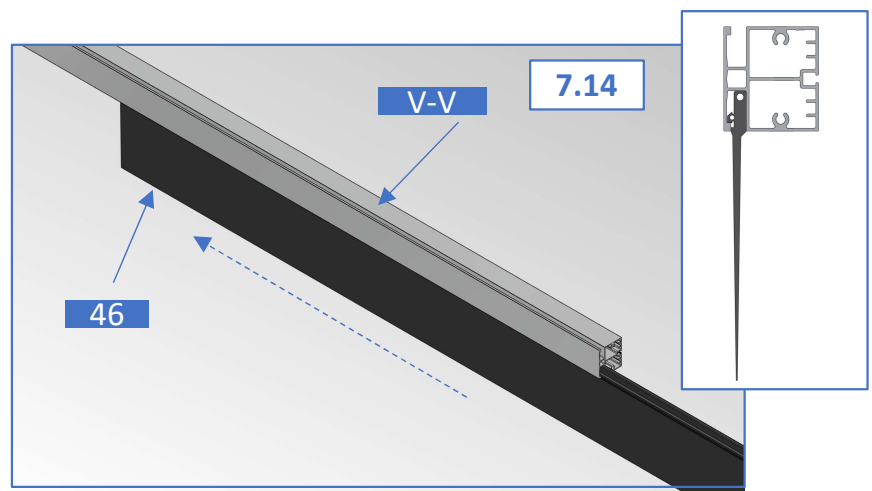
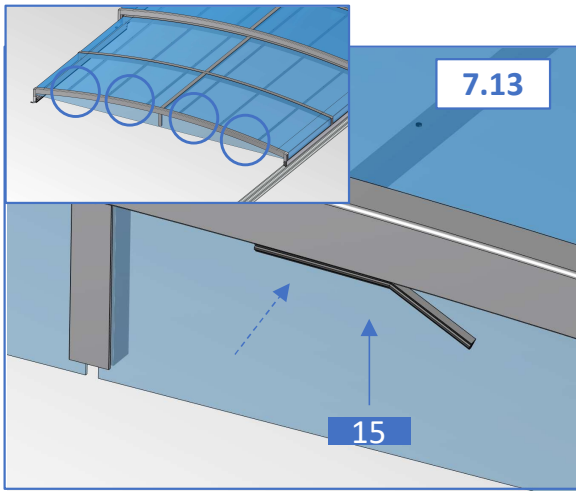

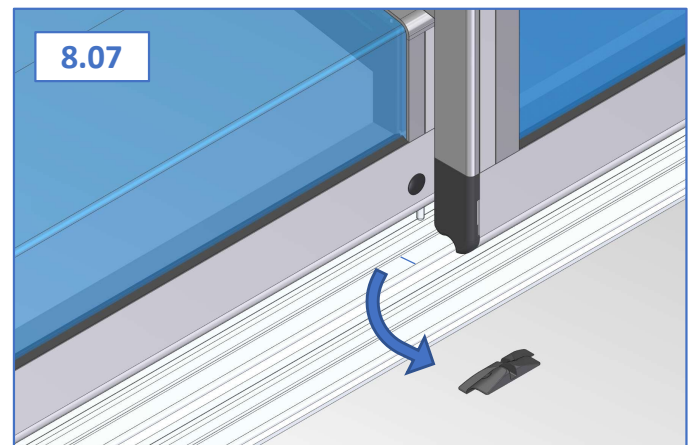
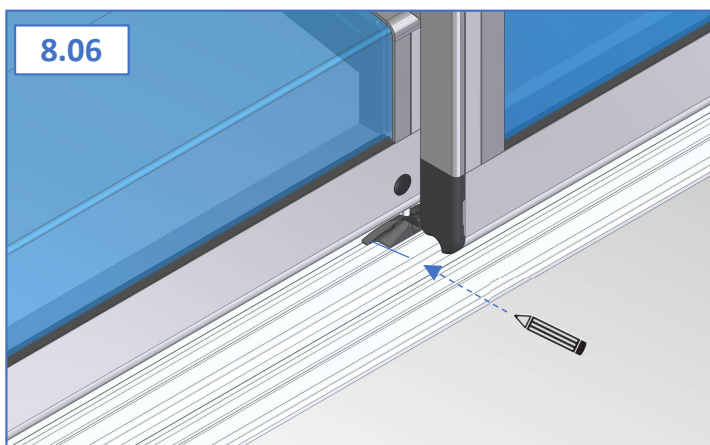
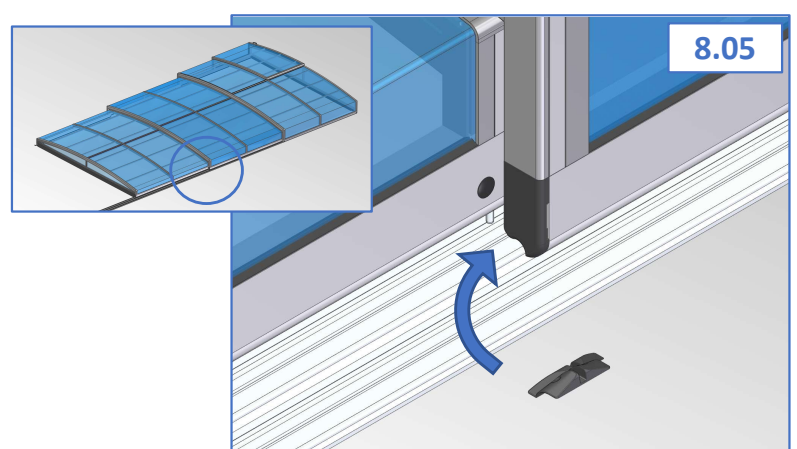
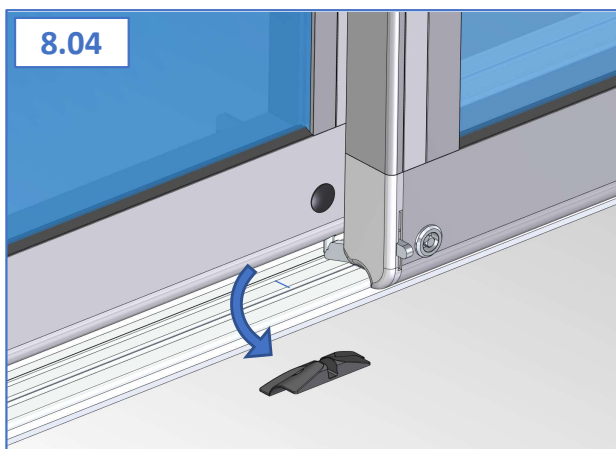
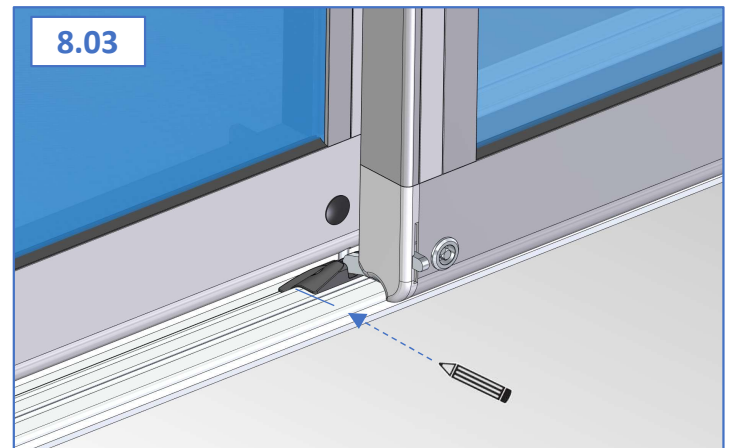
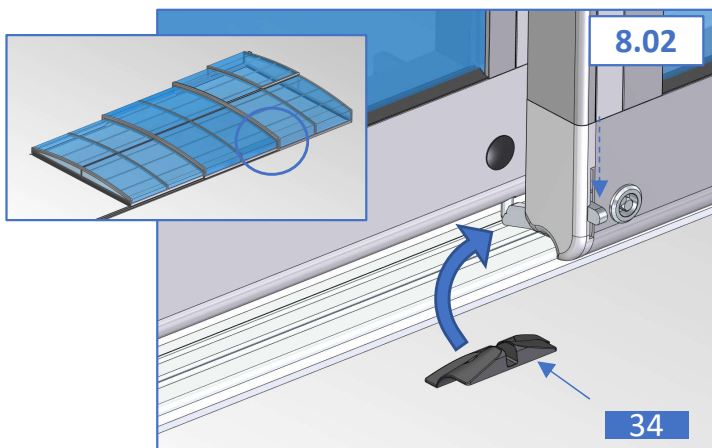
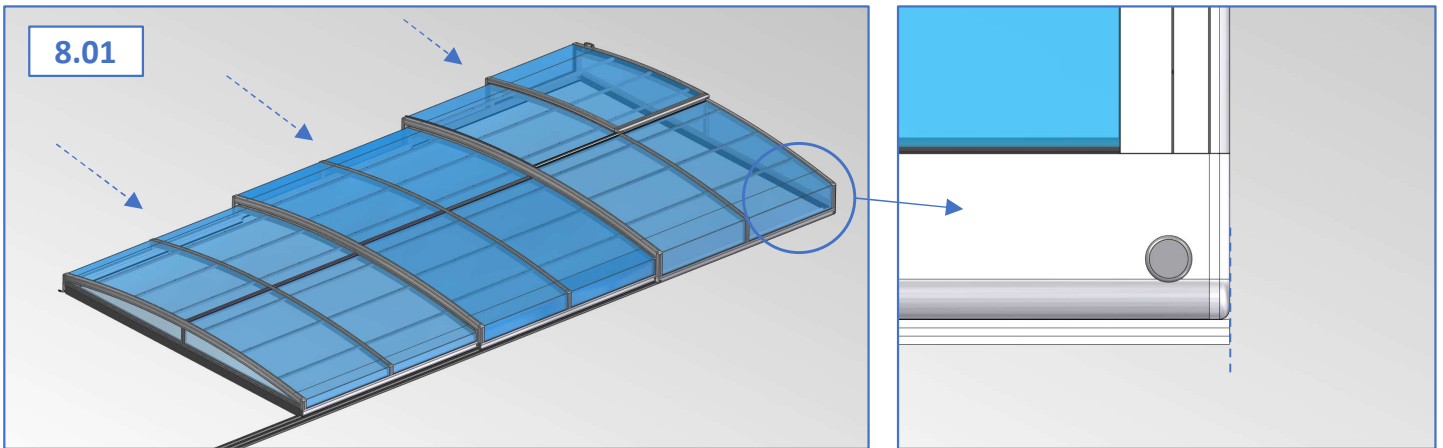



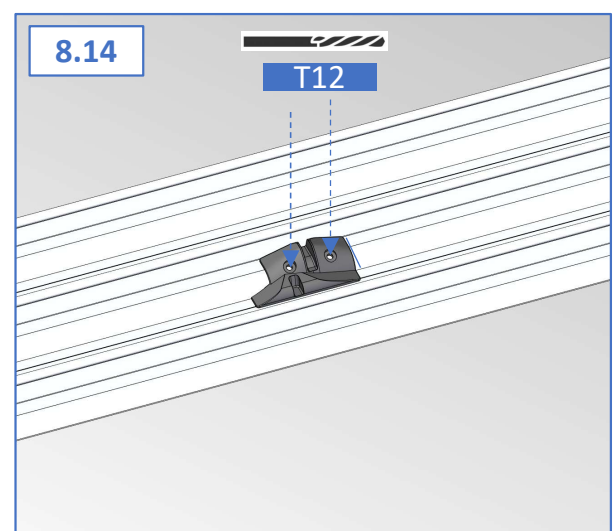
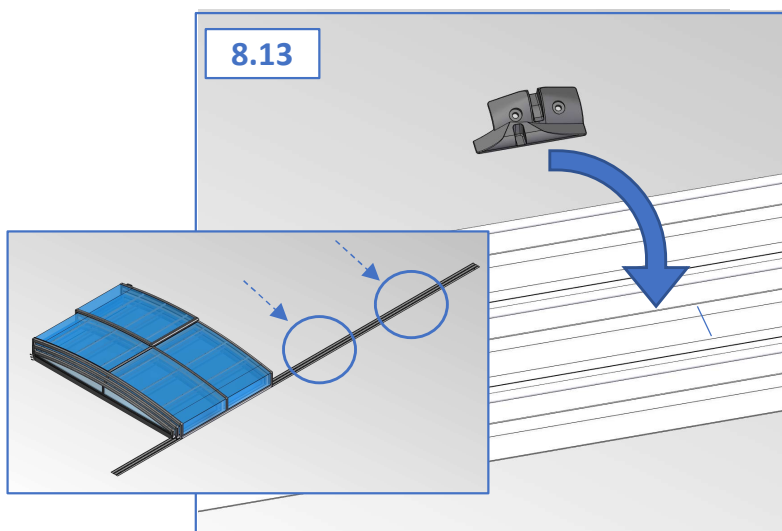
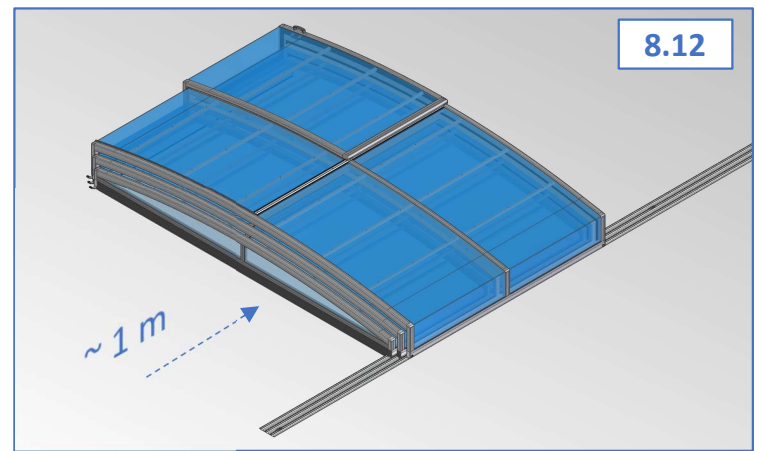
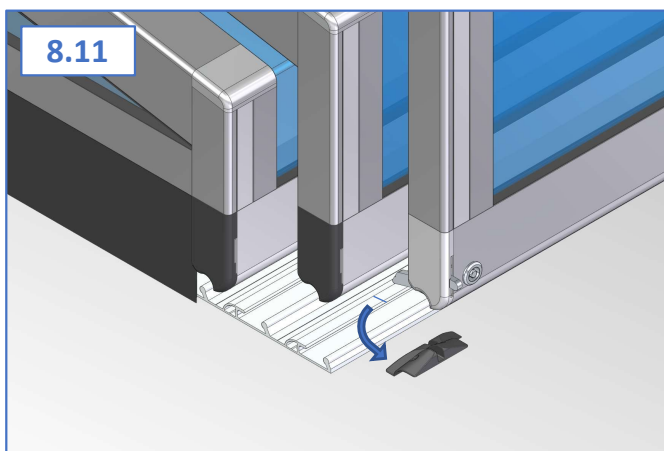
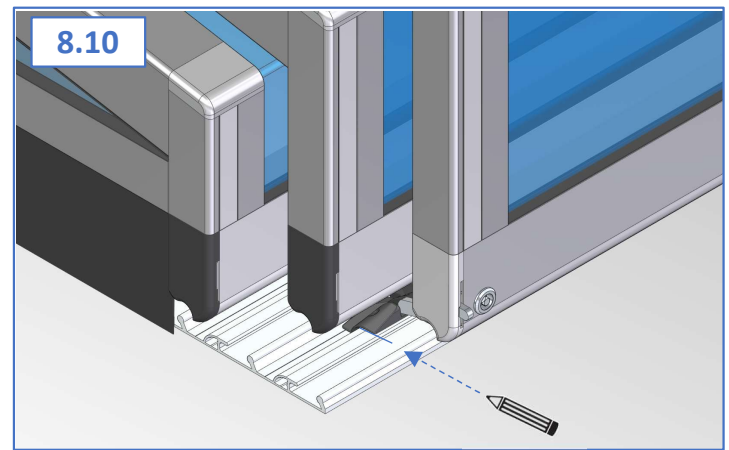
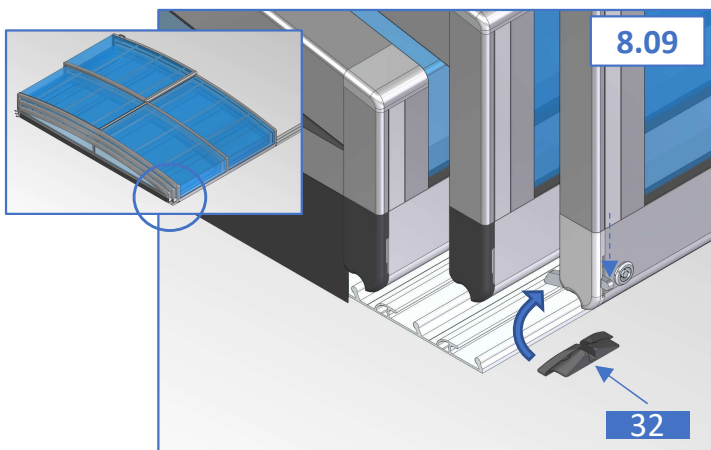
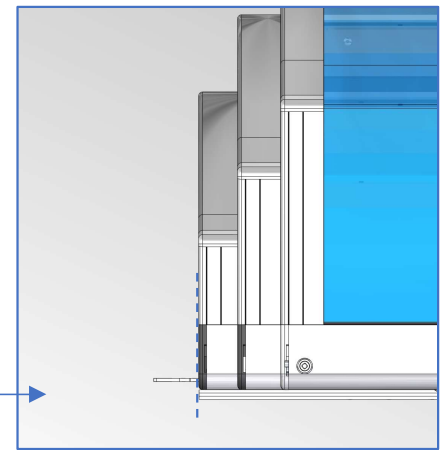
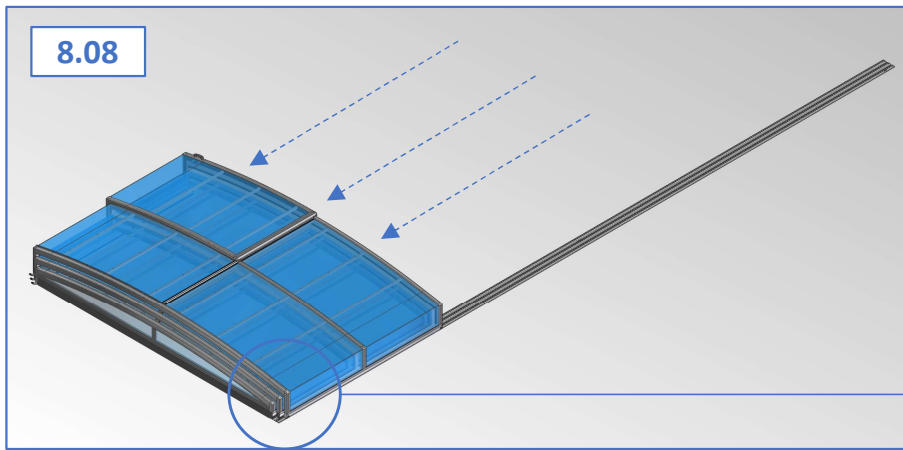



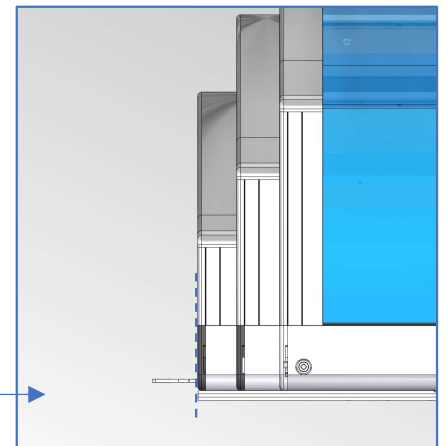
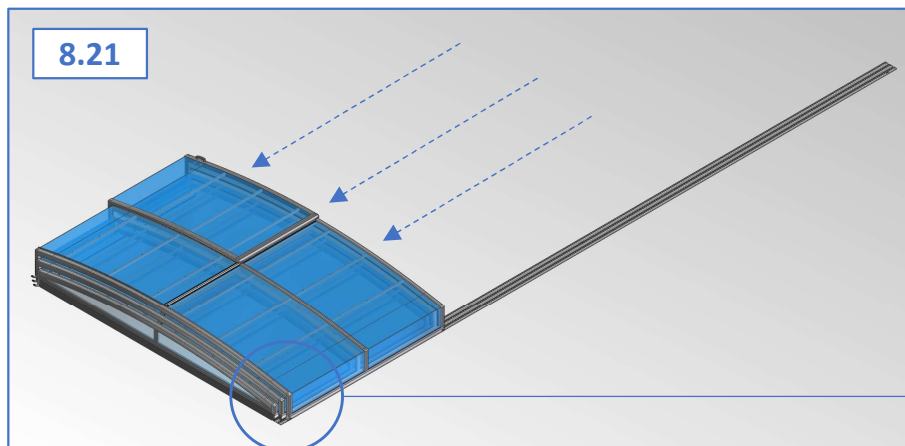
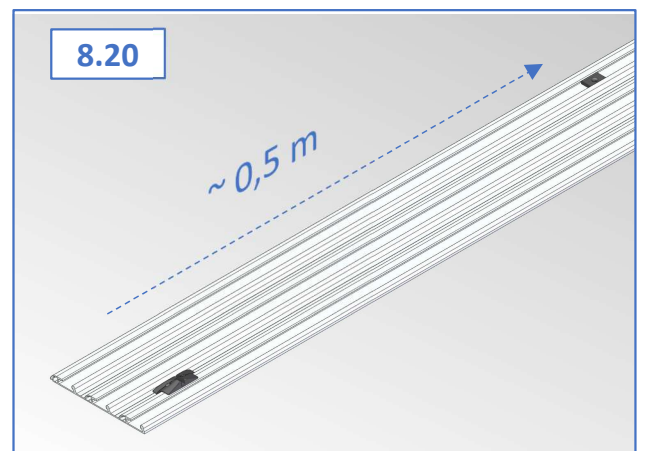
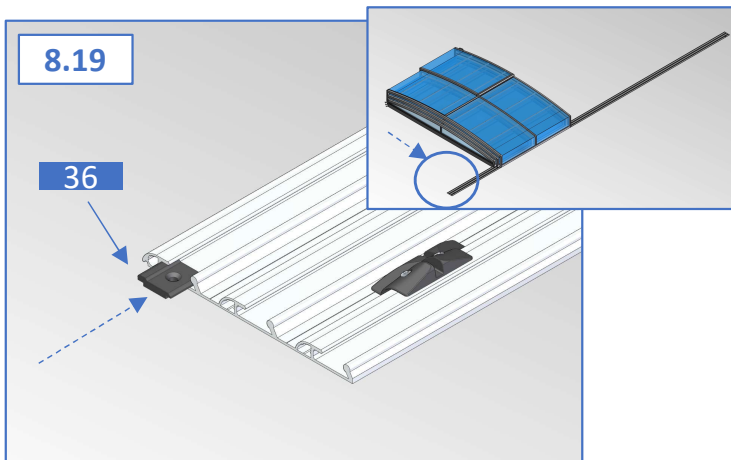
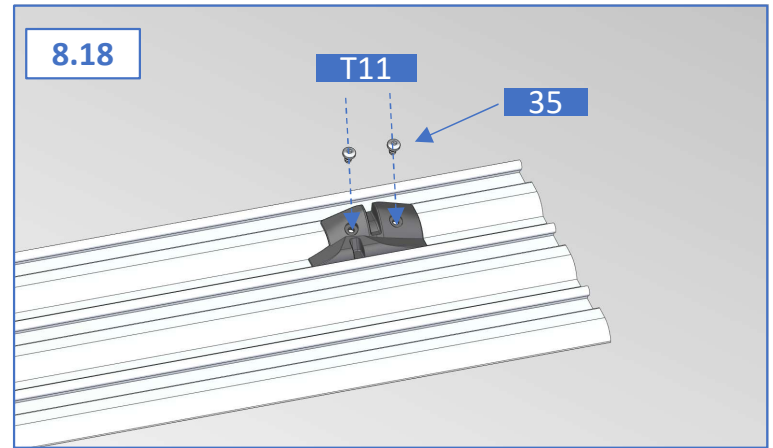
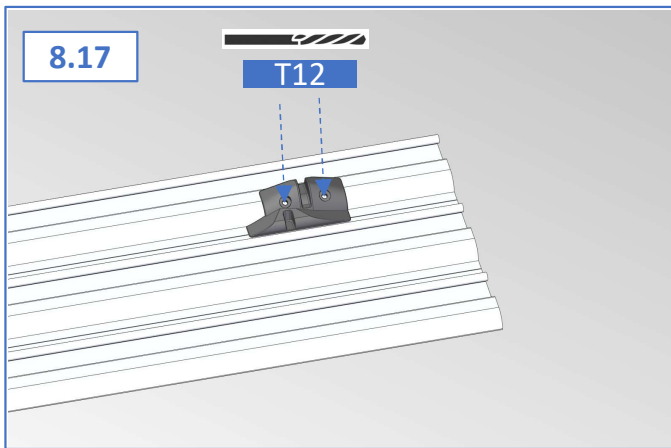
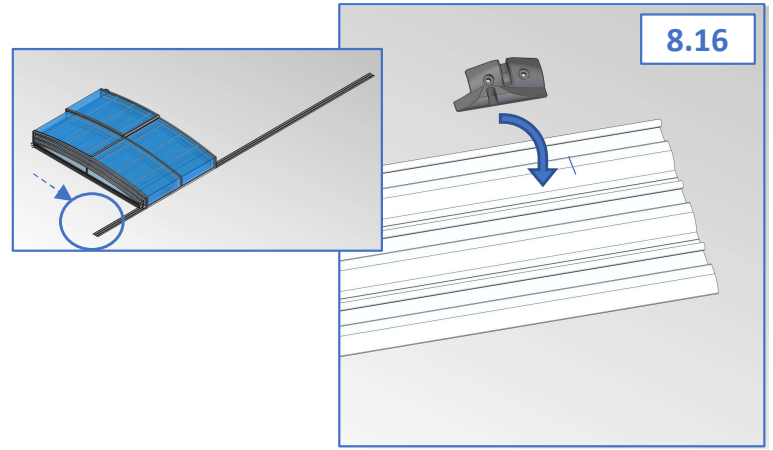
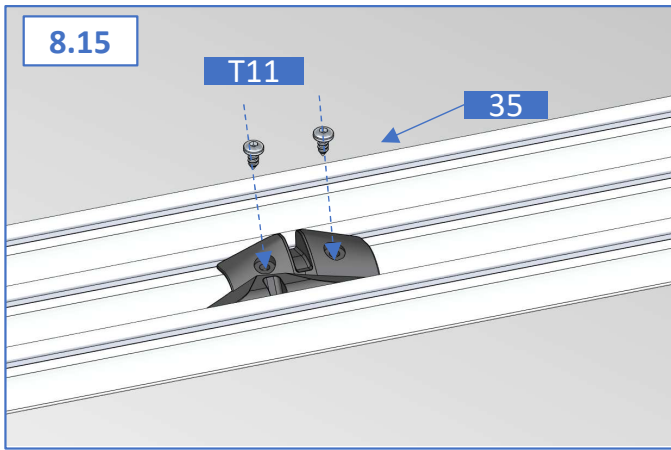

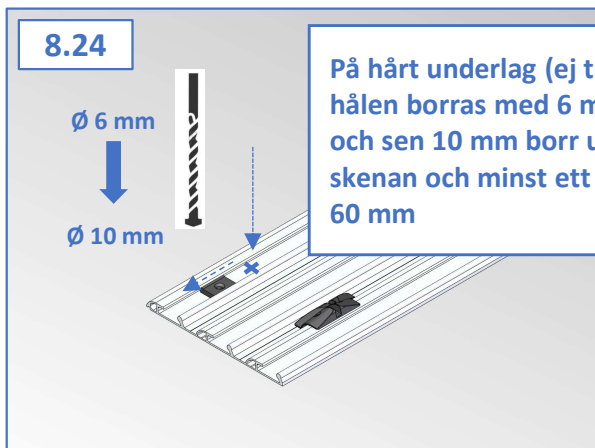
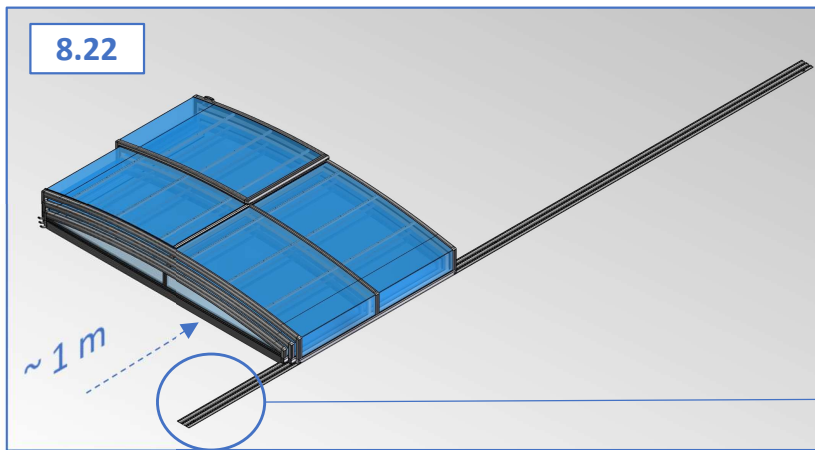

På hårt underlag (ej trä) ska hålen borraras med 6 mm borrh och sen 10 mm borrh under skenan och minst ett djup på 60 mm

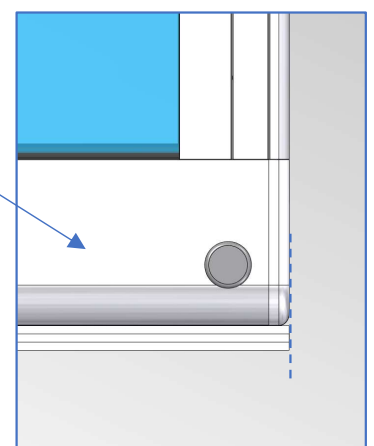
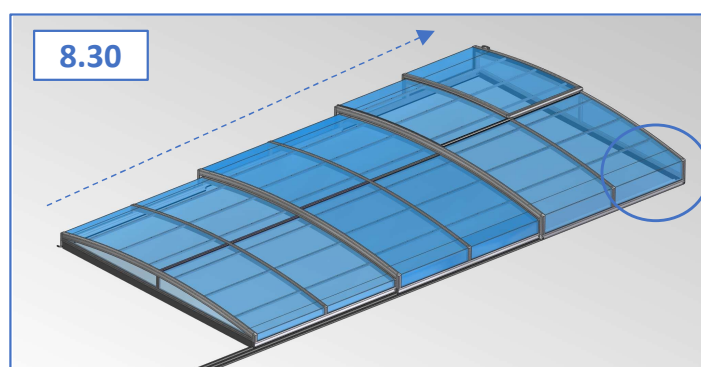
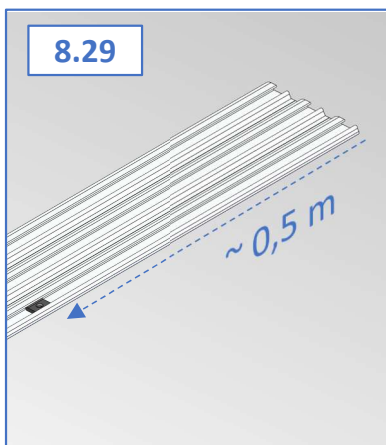
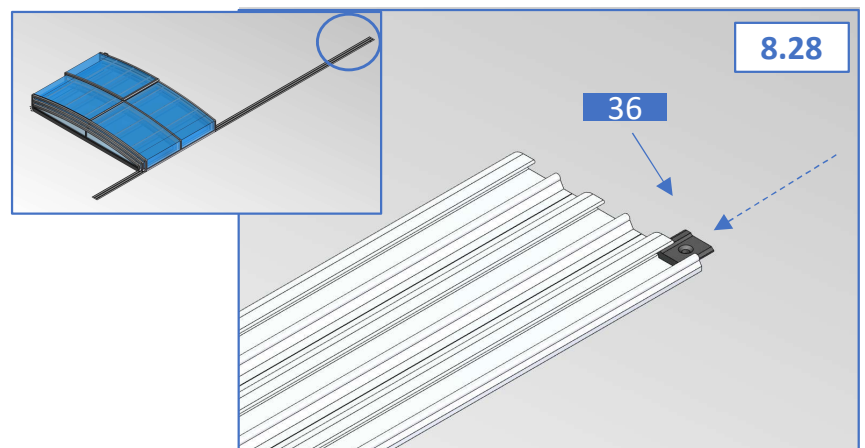
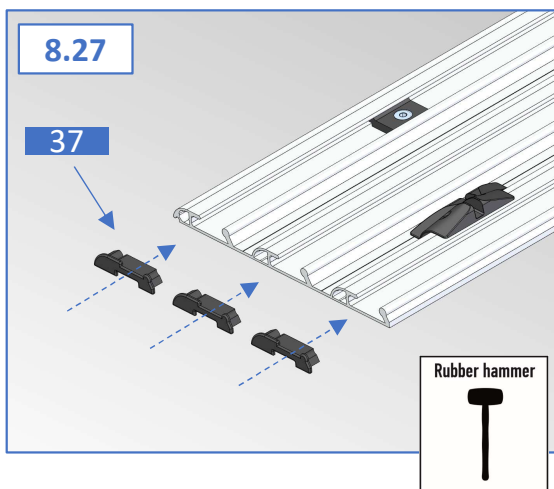
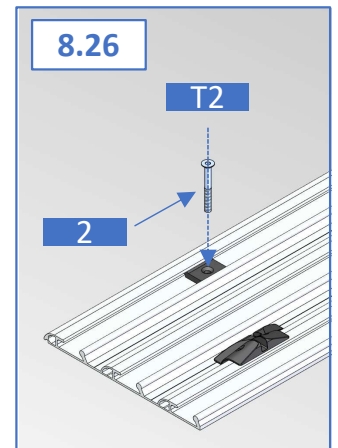
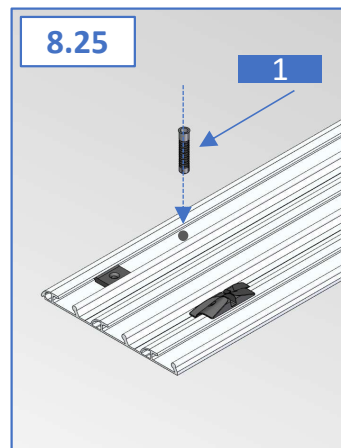

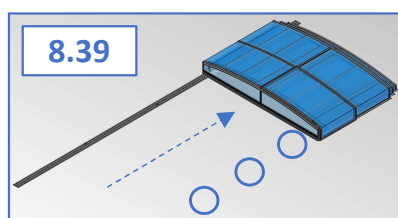
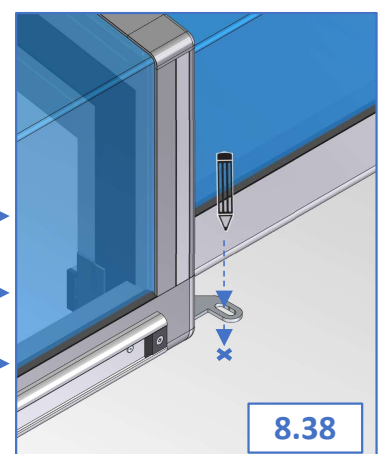
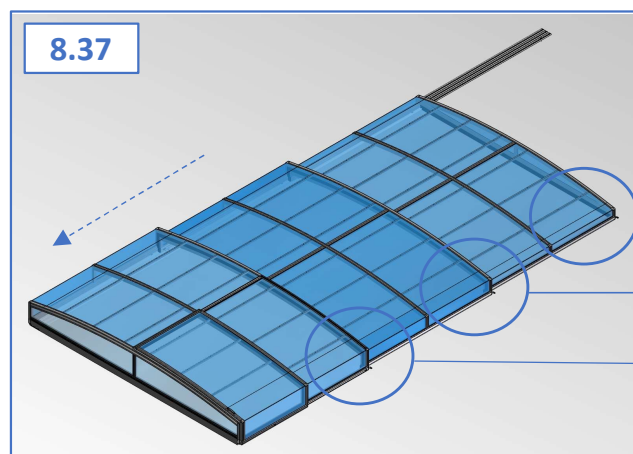
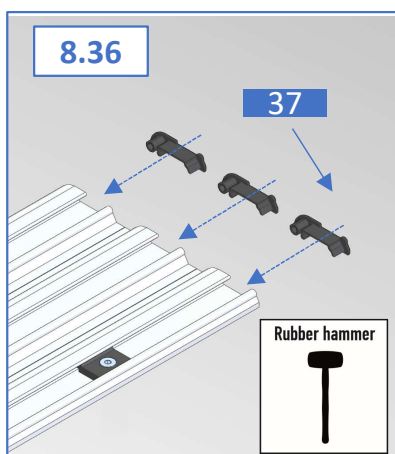
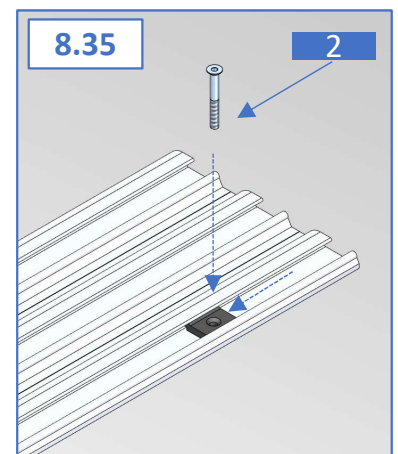
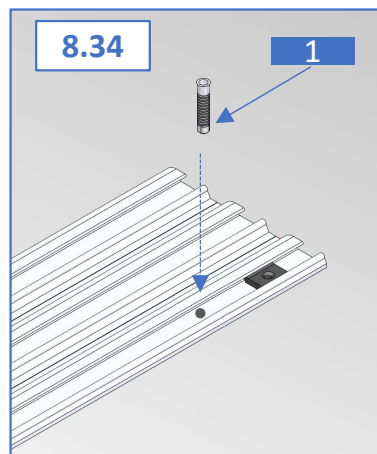
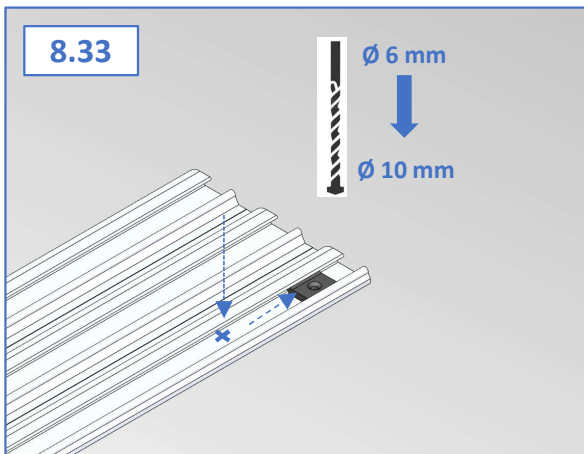
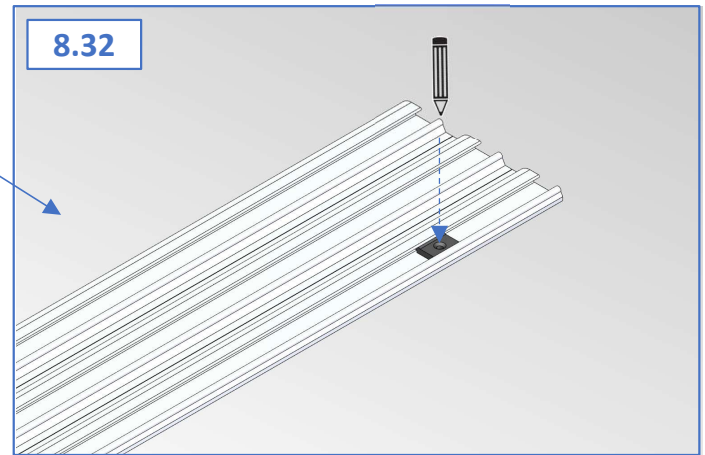
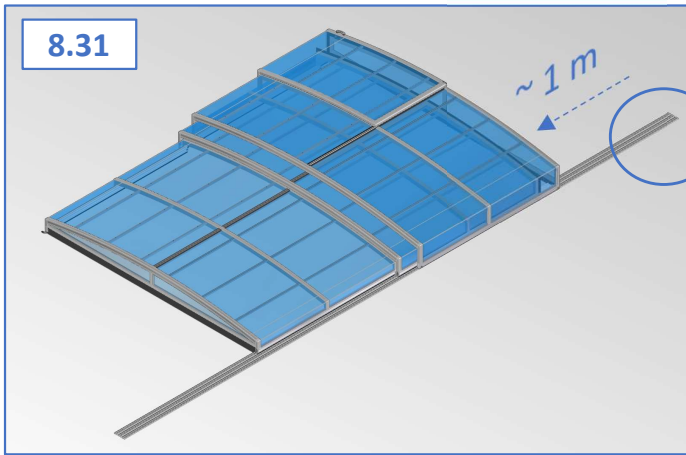

Montering på hårt underlag

Montering på trä.

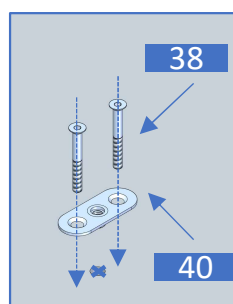
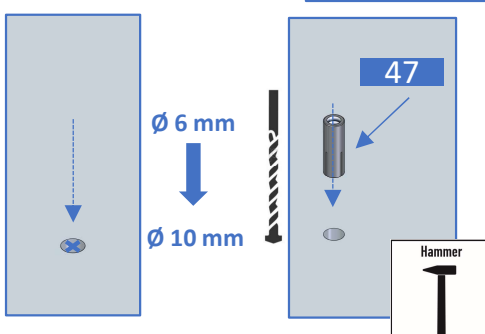
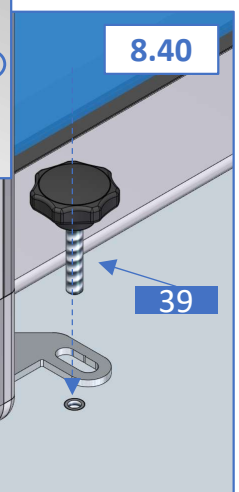
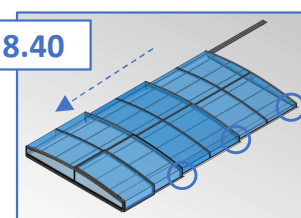



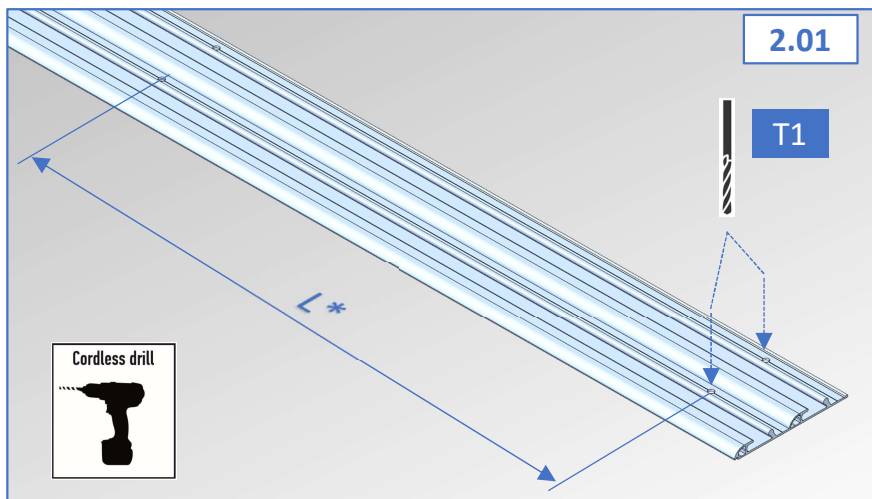

L\* - Borrhålets position  
olika beroende på  
modell!  
(Se sidan 3., Manual II.)

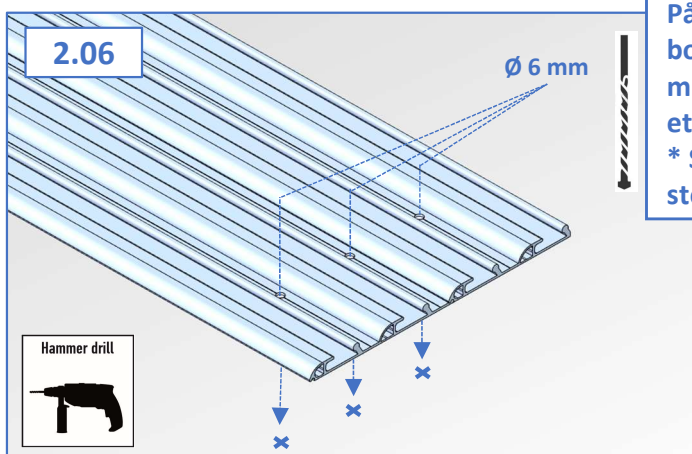
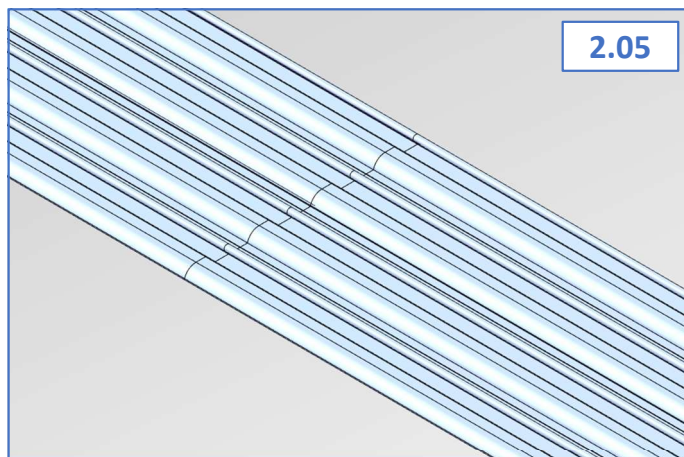
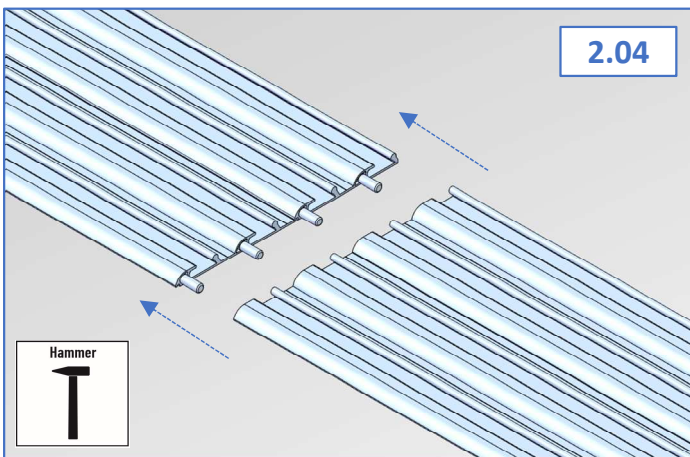
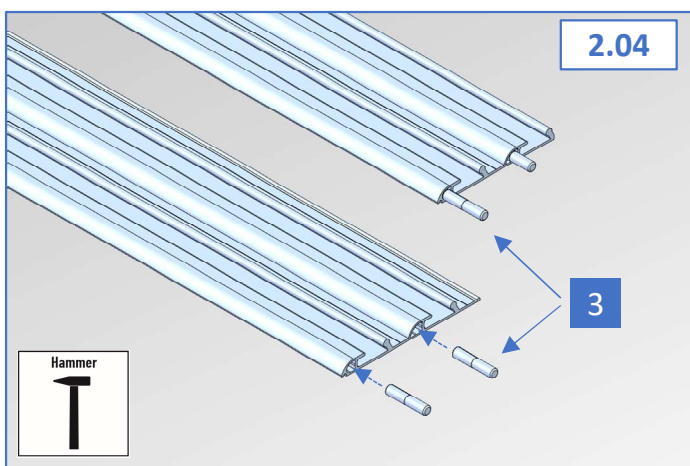

På hårt underlag (ej trä) ska hålen  
borras med 6 mm borrar och sen 10  
mm borrar under skenan och minst  
ett djup på 60 mm  
\* Se bild 8.24 vid montering av  
stoppsbit

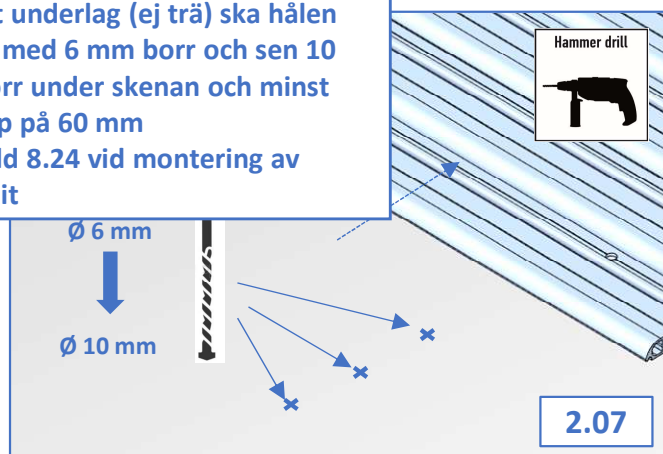



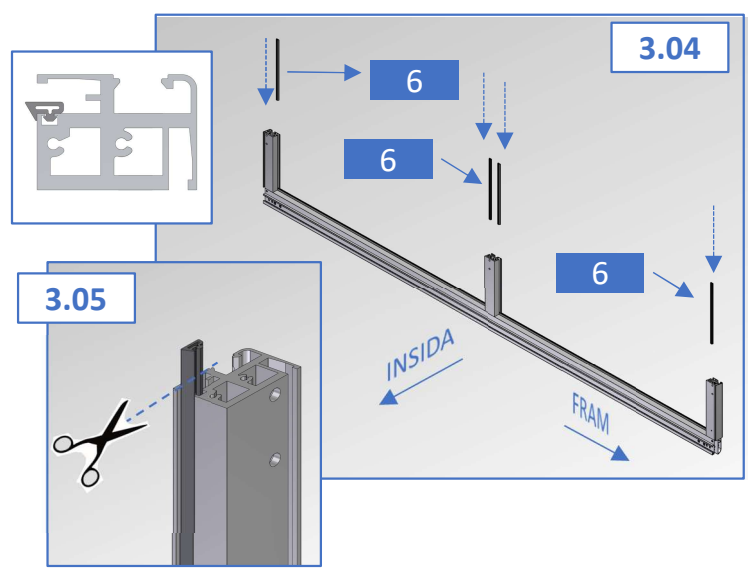
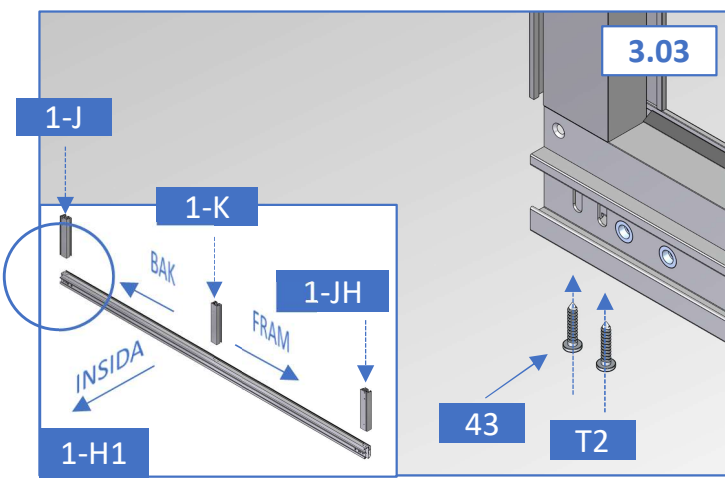
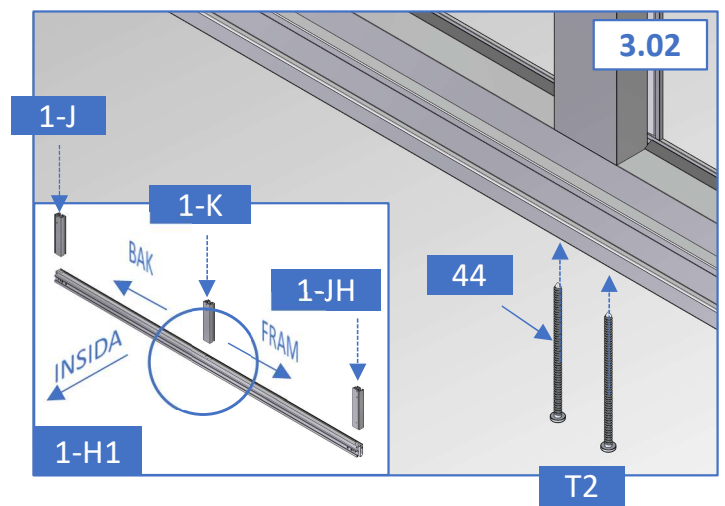
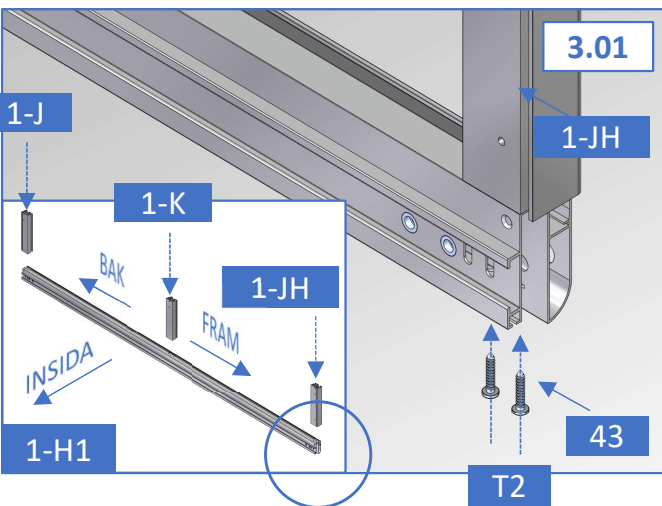
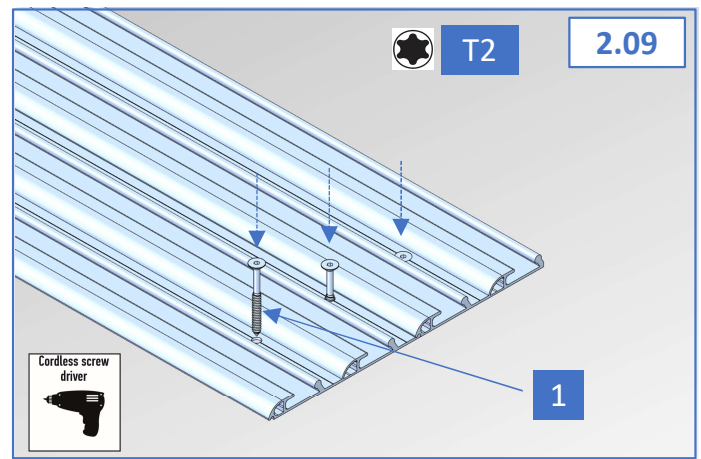
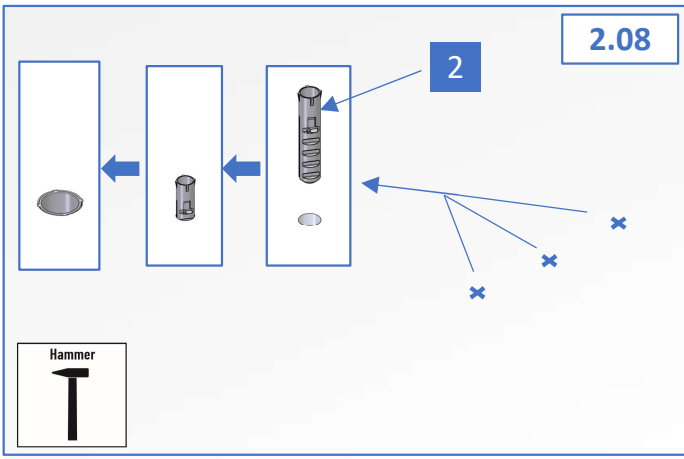

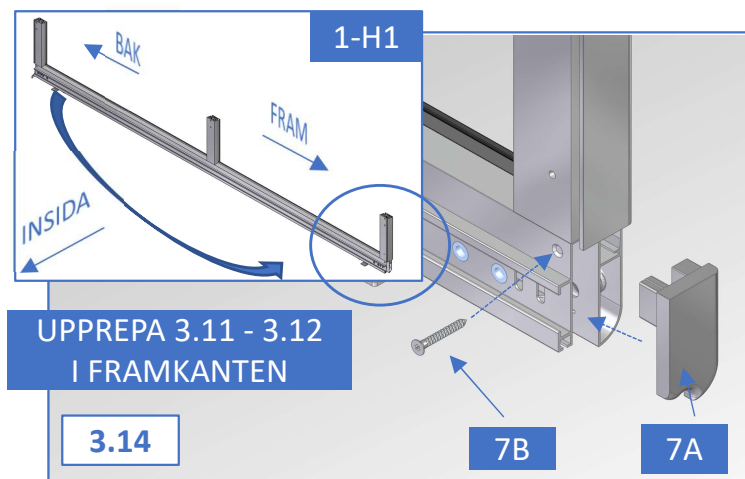
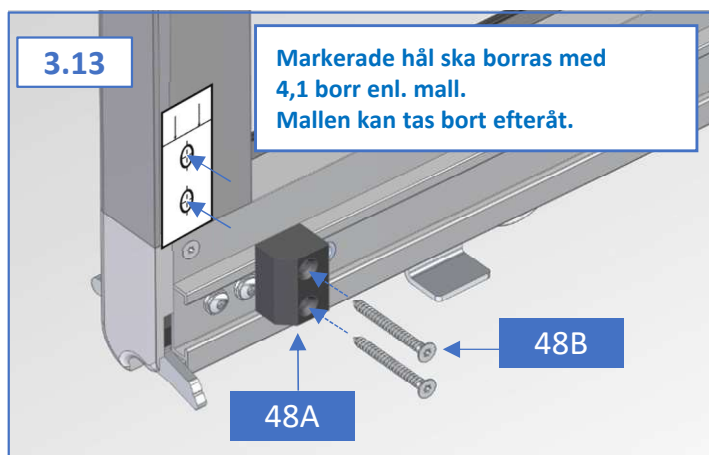
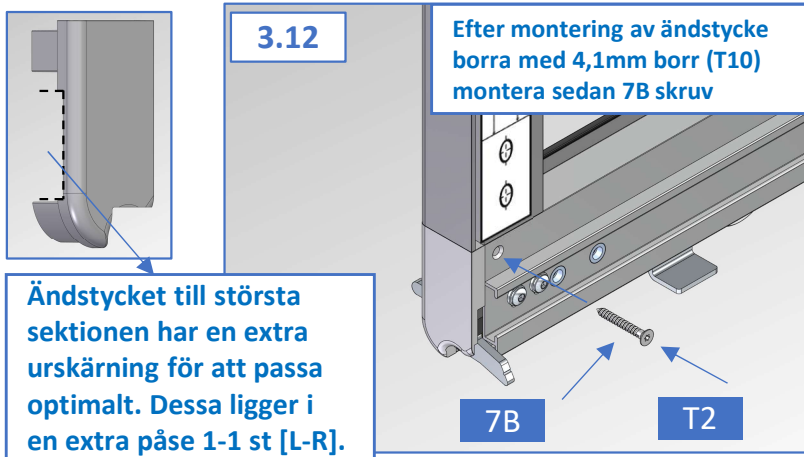
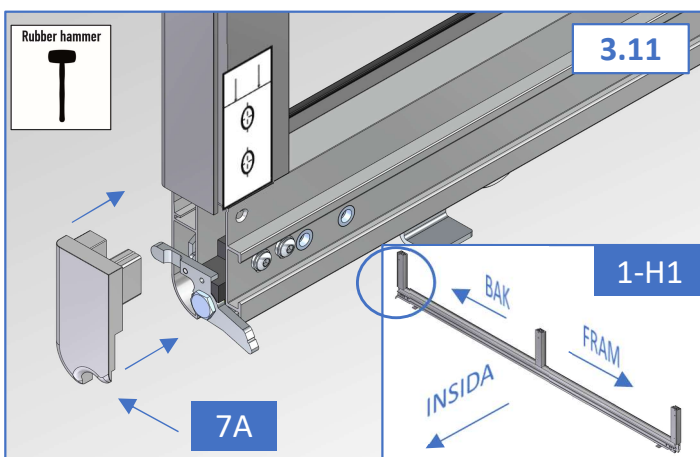
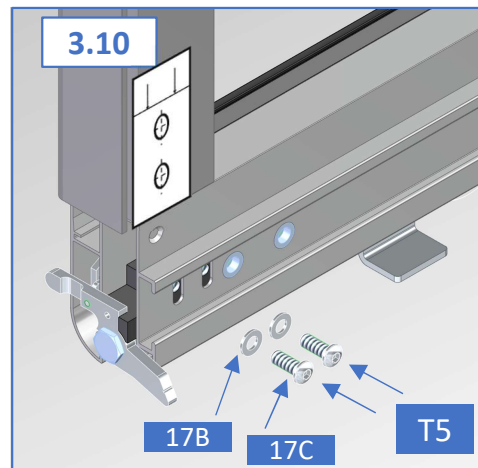
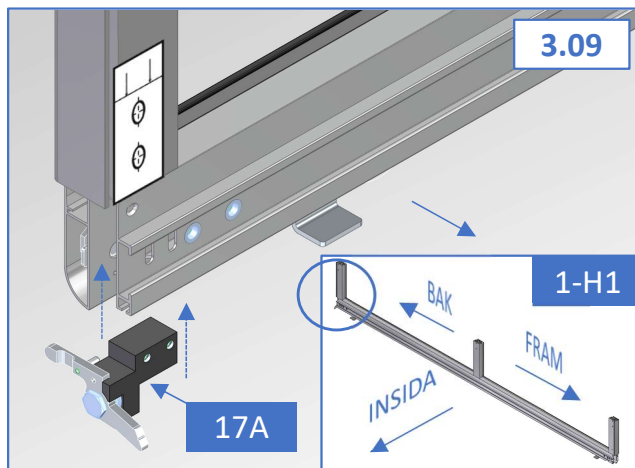
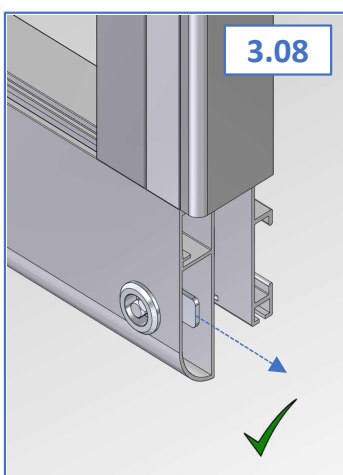
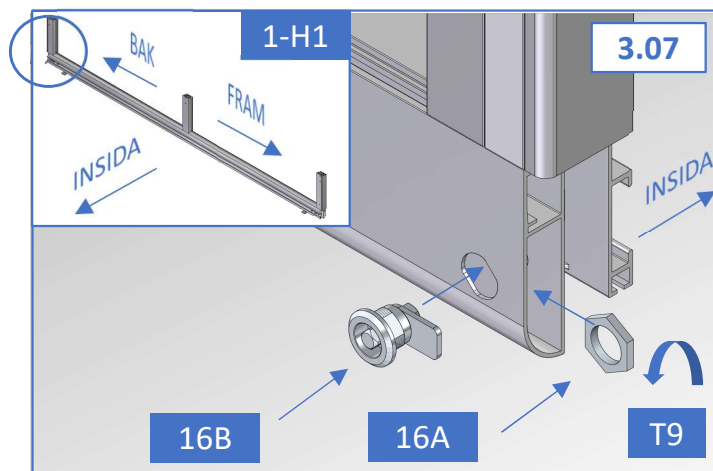
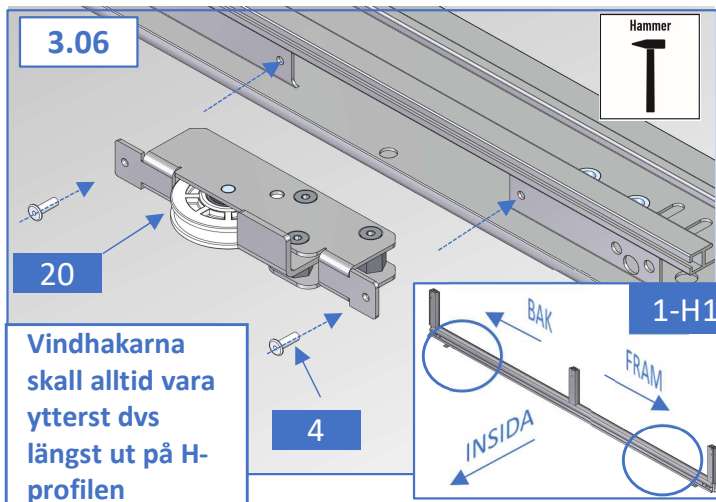

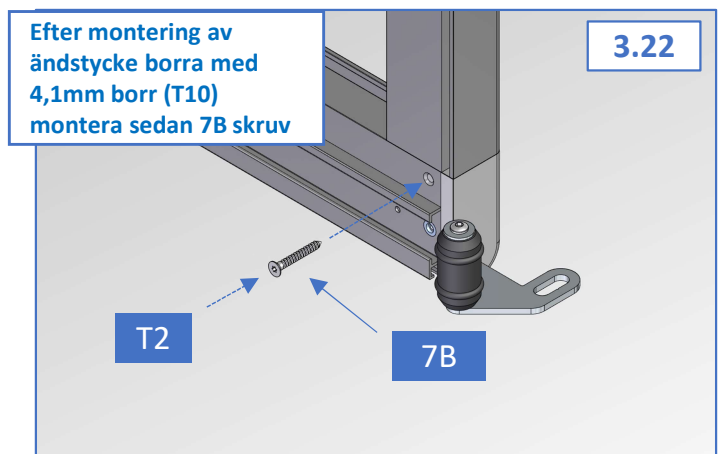
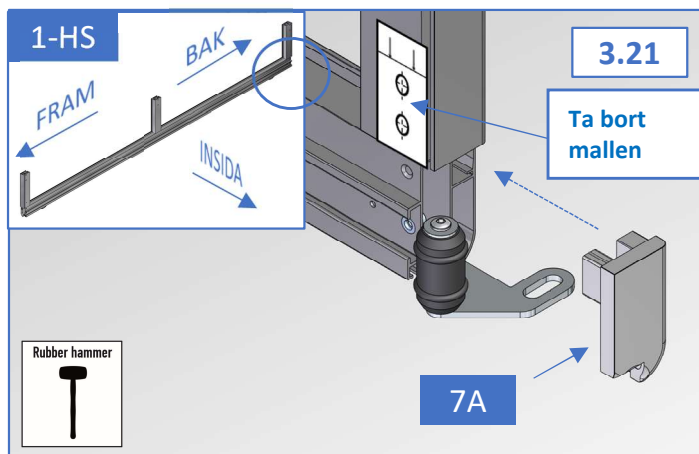
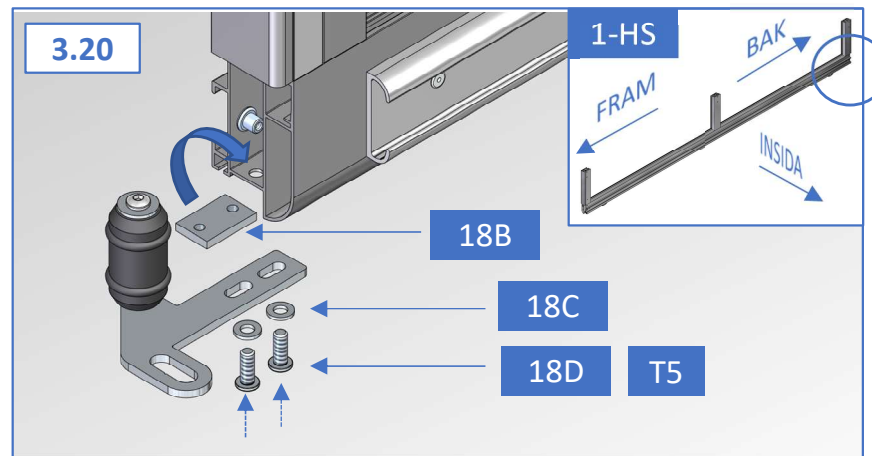
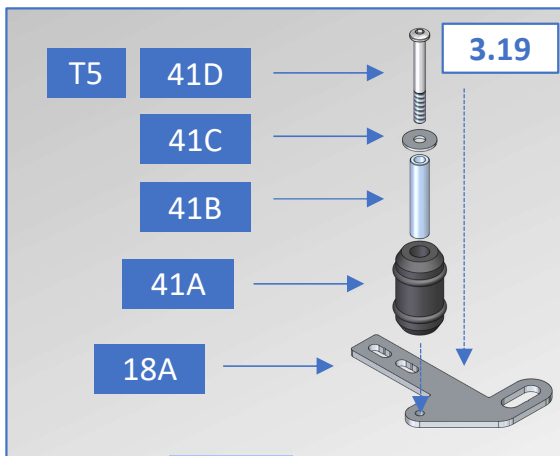
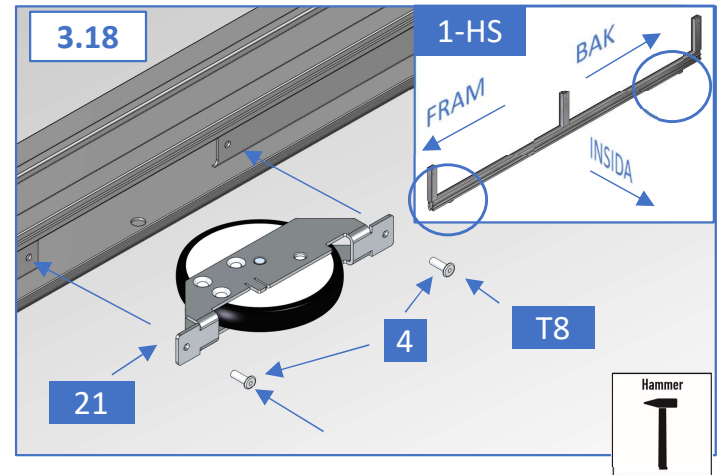
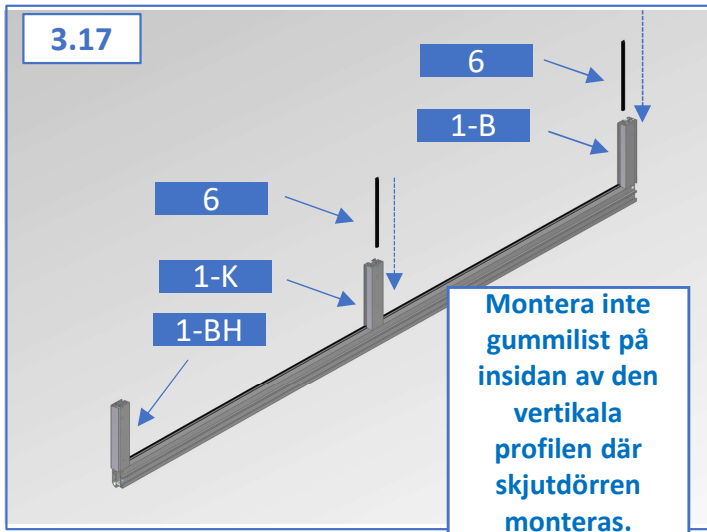
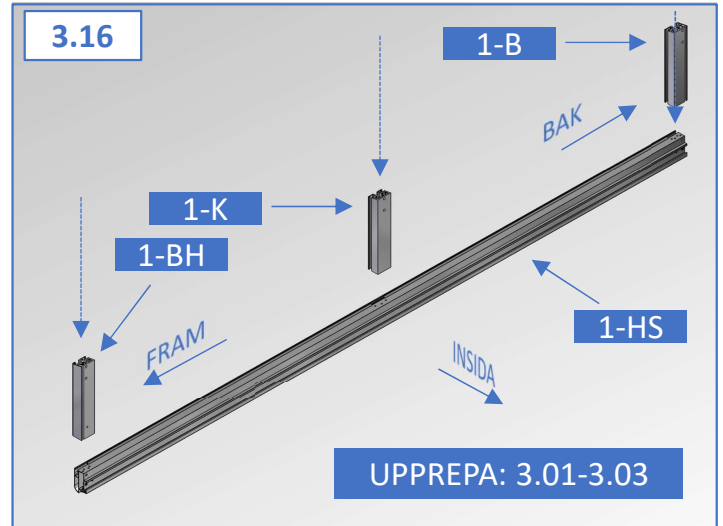
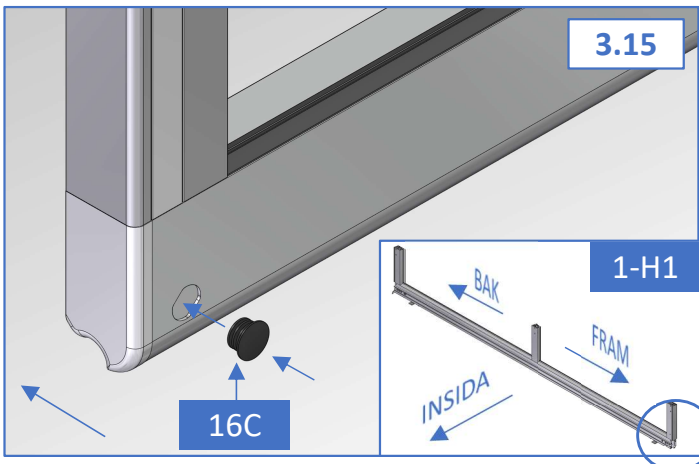

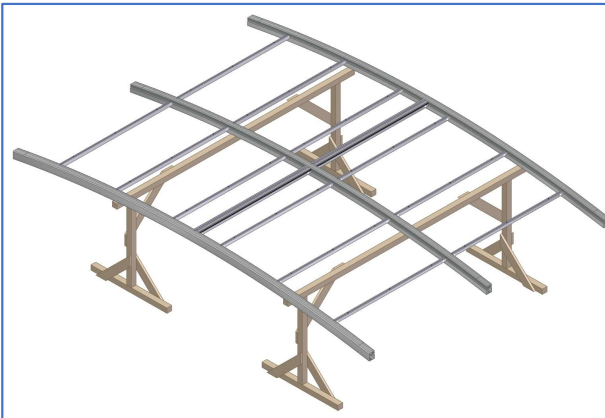
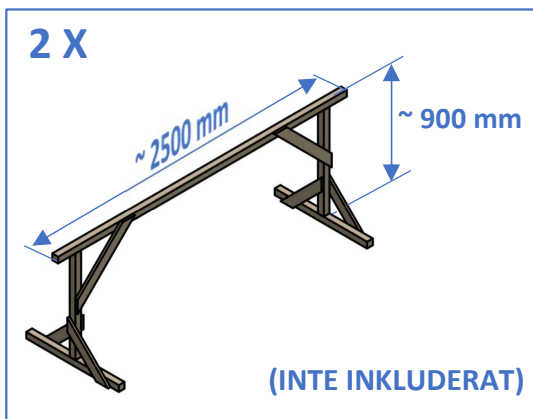
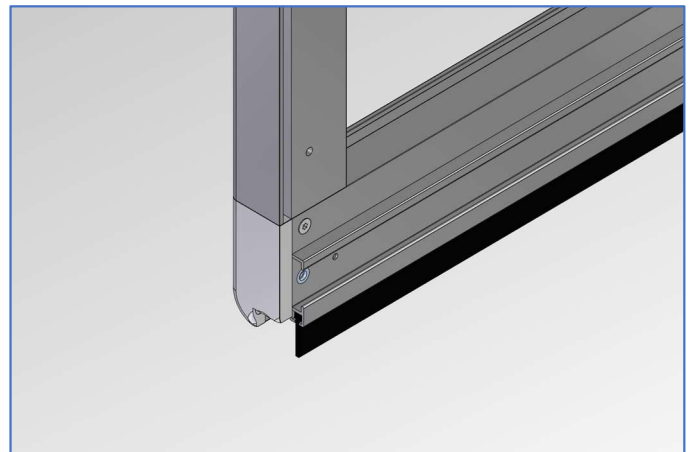
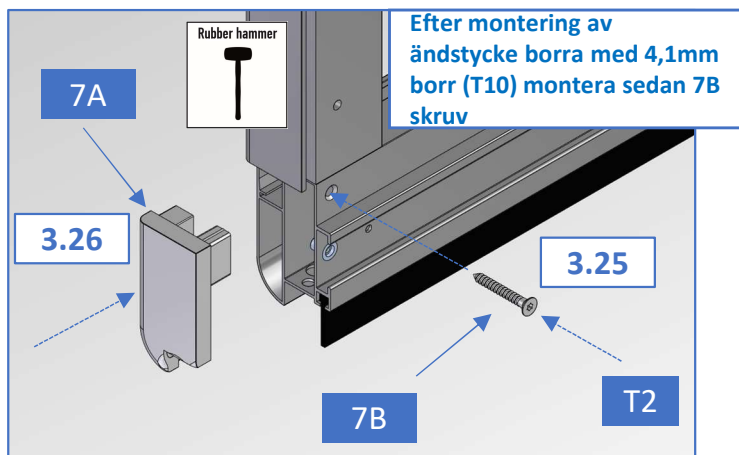
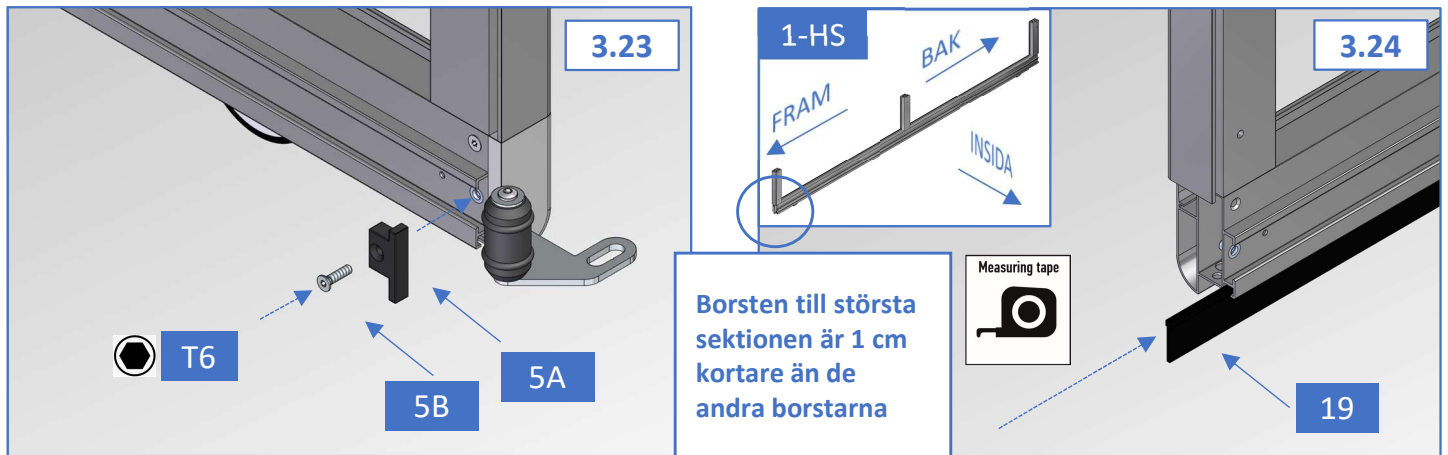

Vi rekommenderar för säkert och ergonomiskt arbete att följande moment utförs på bockar, som inte är inkluderade i boxen!

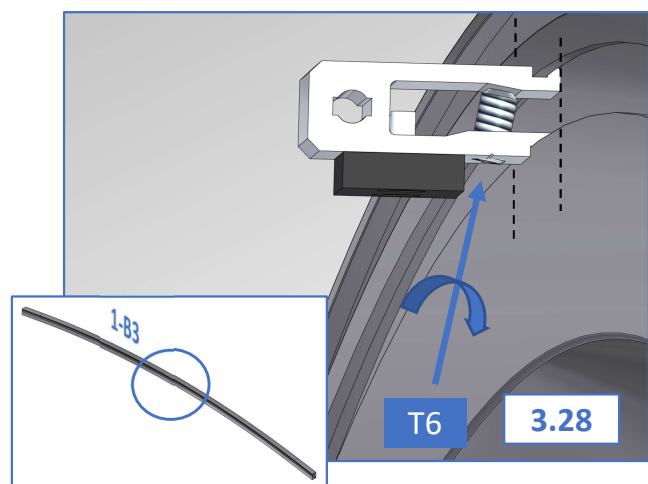
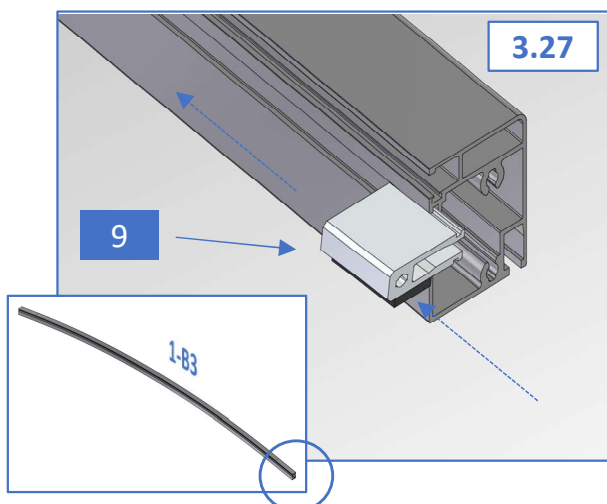





[H3] – 3 st / sida  
[H4; H4M] – 4 st / sida

3.29

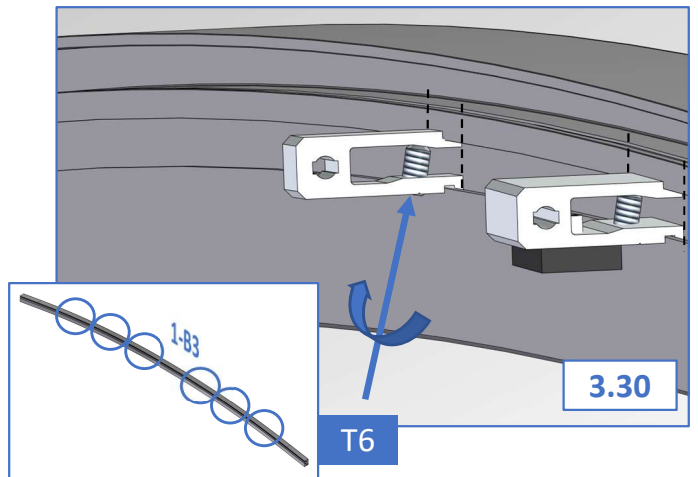
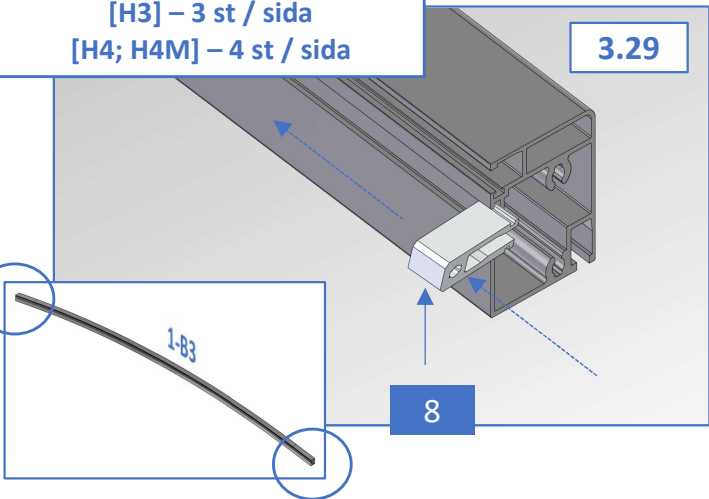

3.31

9

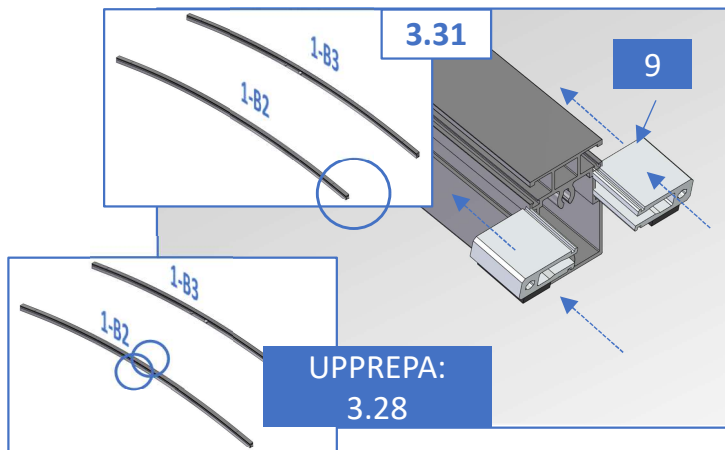

3.32

8

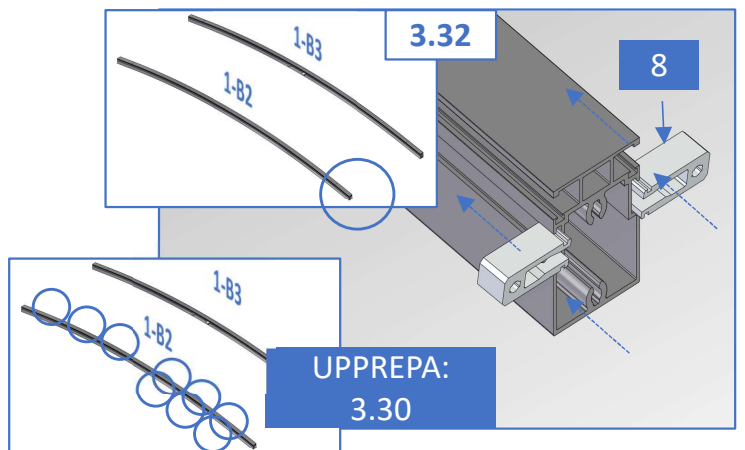

3.33

9

UPPREPA:  
3.28

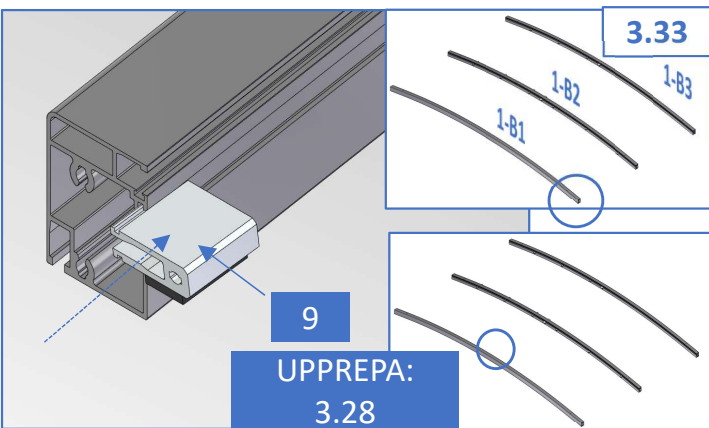

3.34

9

UPPREPA:  
3.30

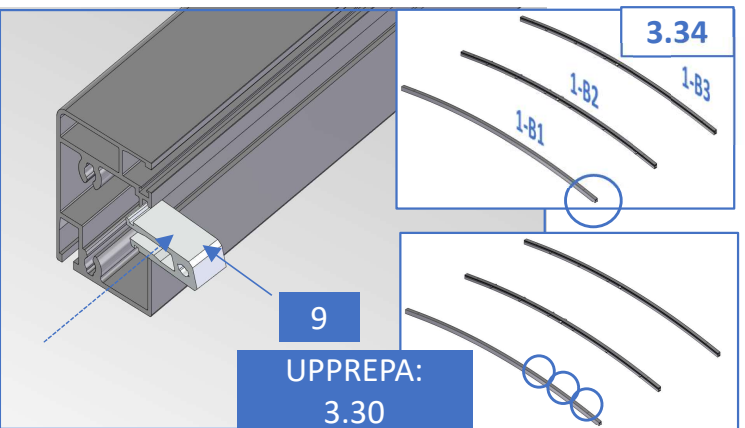

3.35

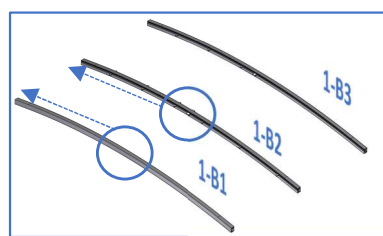
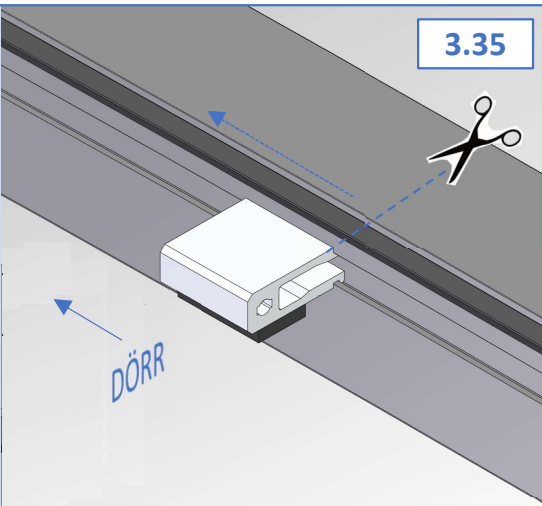

Klipp av insidans gummilist (nr 6) och ta bort det från profilen 1-B1 och 1-B2 där skjutdörren monteras.

3.36

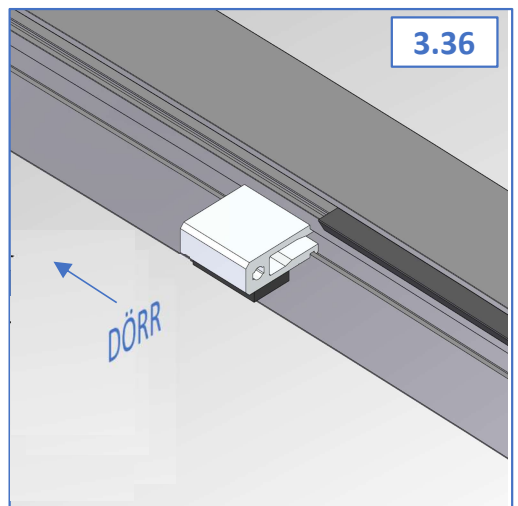



Insidans gummilist(nr 6) skall vara placerad på motsatt sida (på G-profilen) från skjutdörren. Flytta listen om det behövs

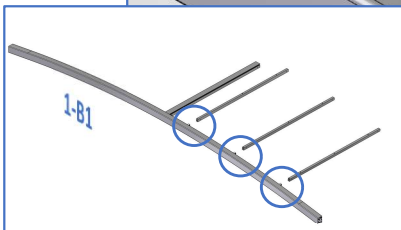
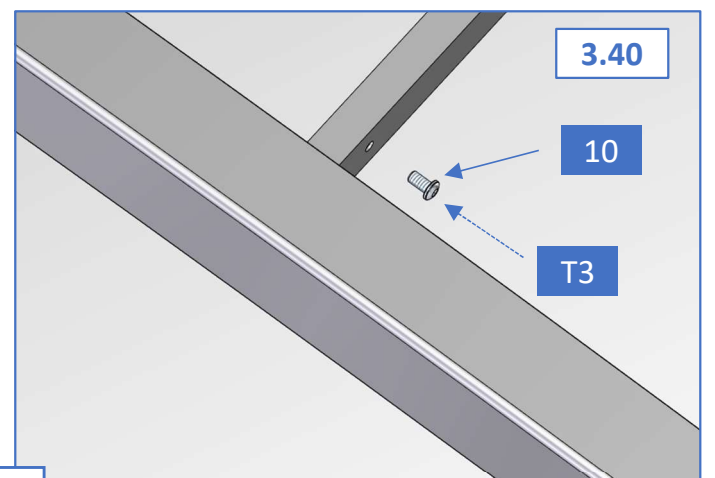
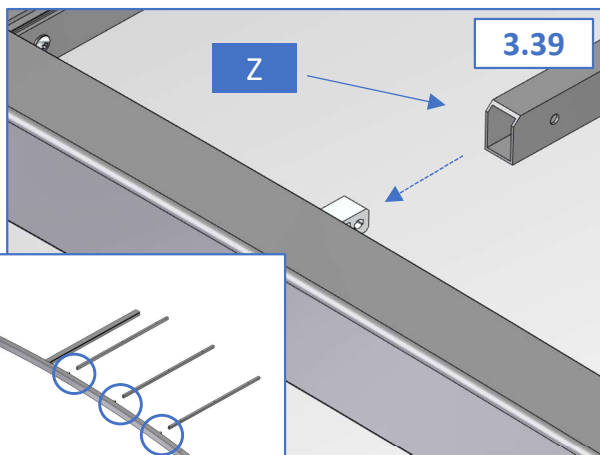
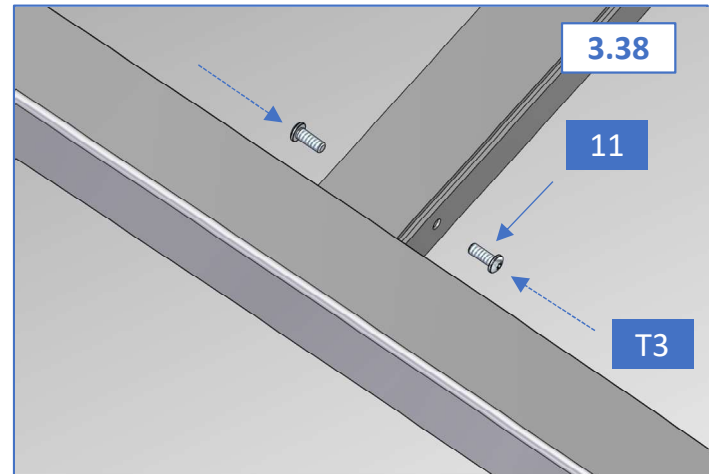
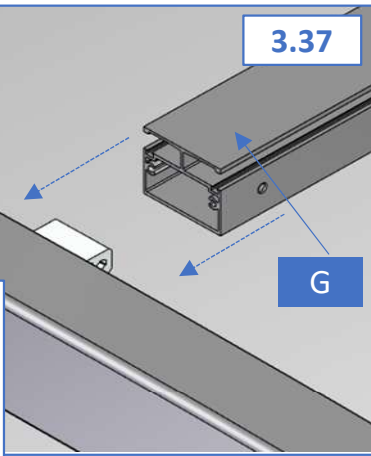
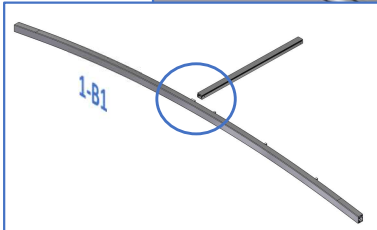

Montera bågprofilen på Z-profilerna en och en från ena änden till andra som en solfjäder. 2 personer krävs.

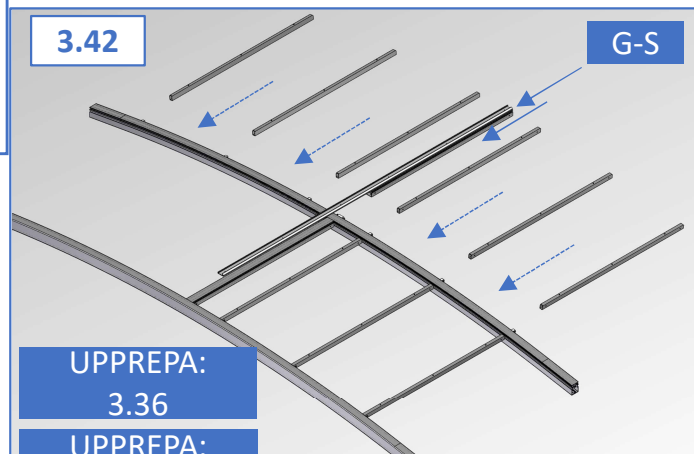
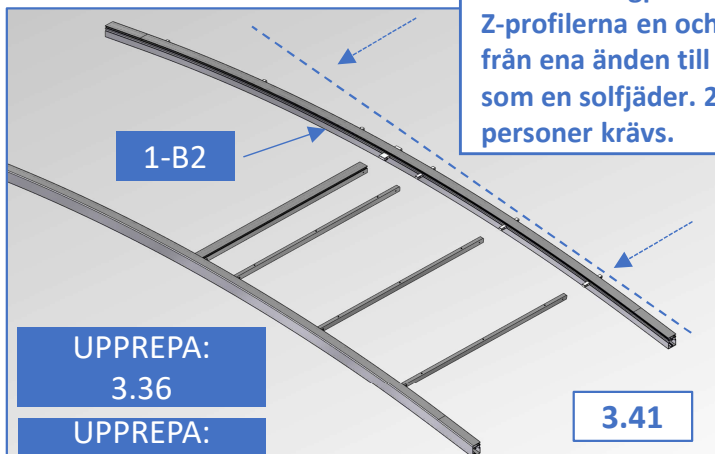

UPPREPA:  
3.36

UPPREPA:  
3.38

3.41

UPPREPA:  
3.36

UPPREPA:  
3.38

G-S

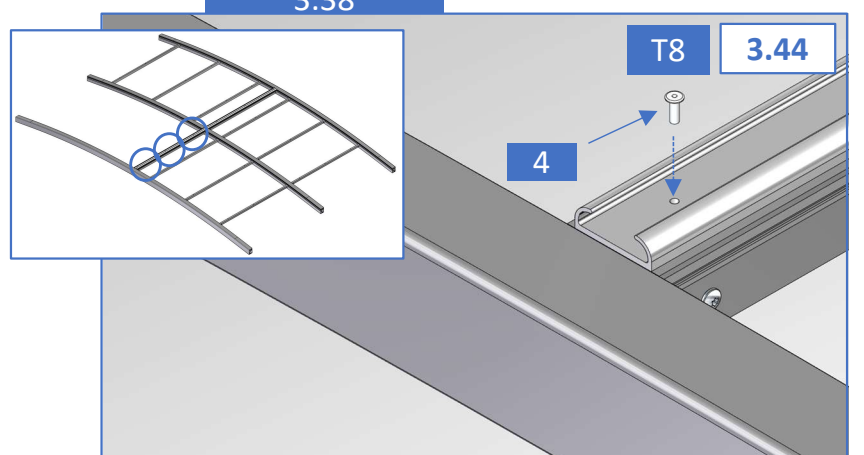
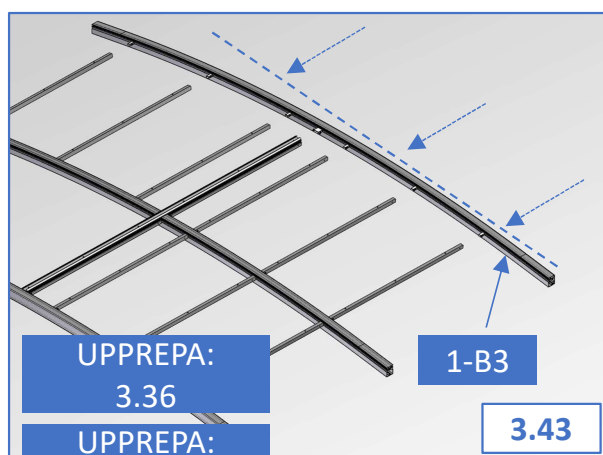

UPPREPA:  
3.36

UPPREPA:  
3.38

3.43

T8

3.44

4

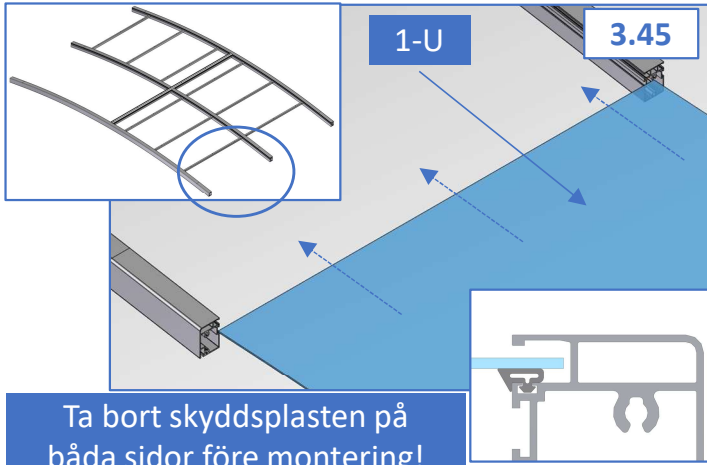

Ta bort skyddsplasten på båda sidor före montering!

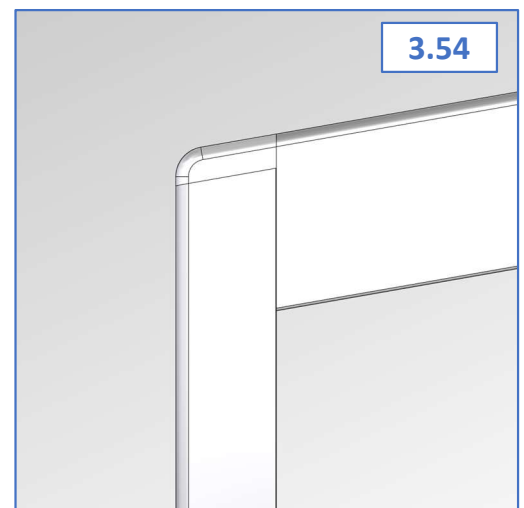
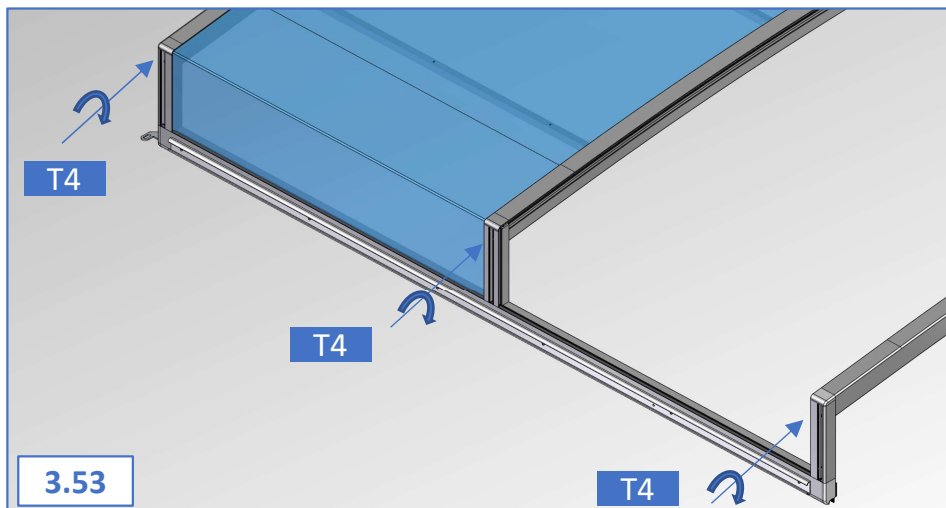
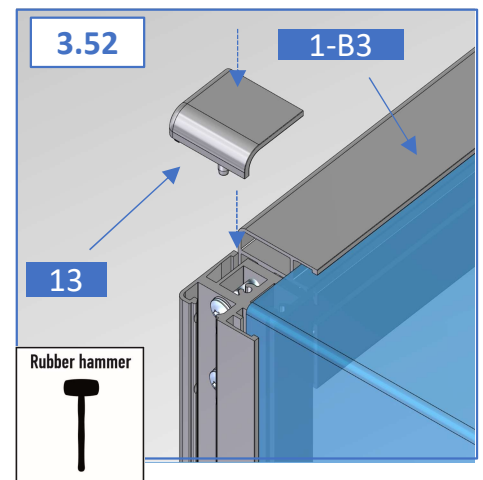
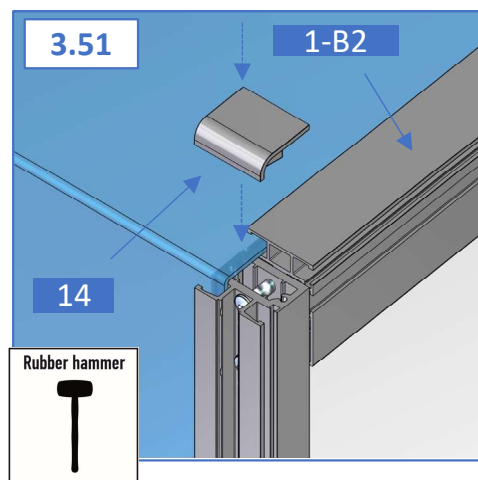
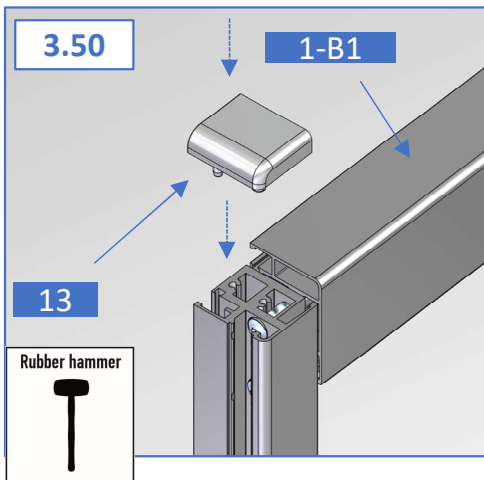
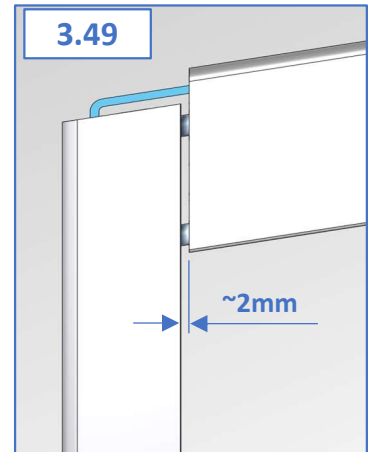
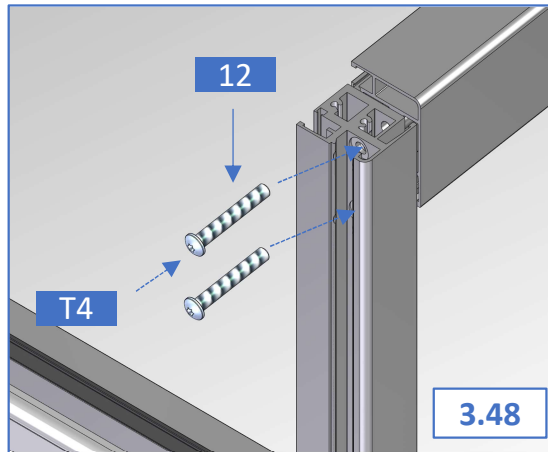
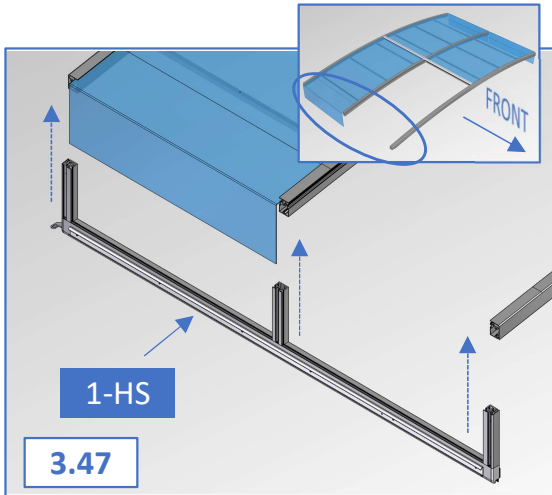
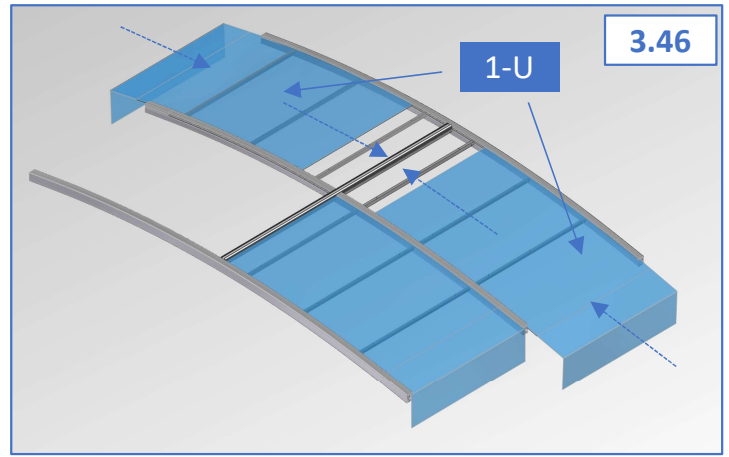

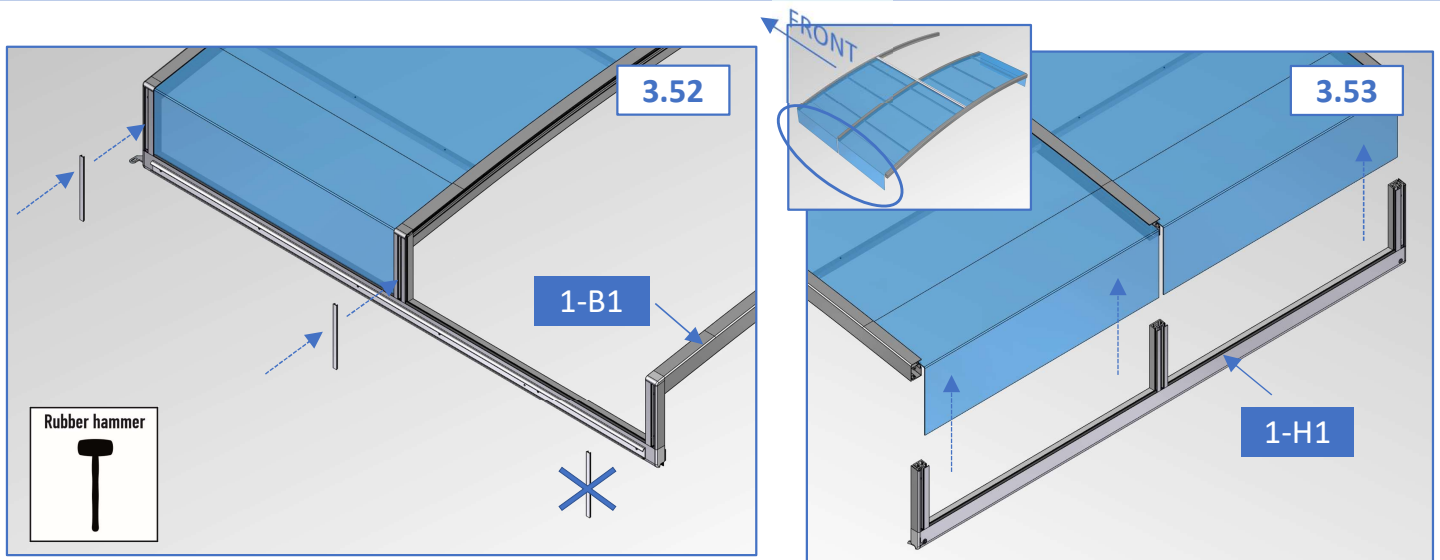

UPPREPA: 3.45 – 3.52

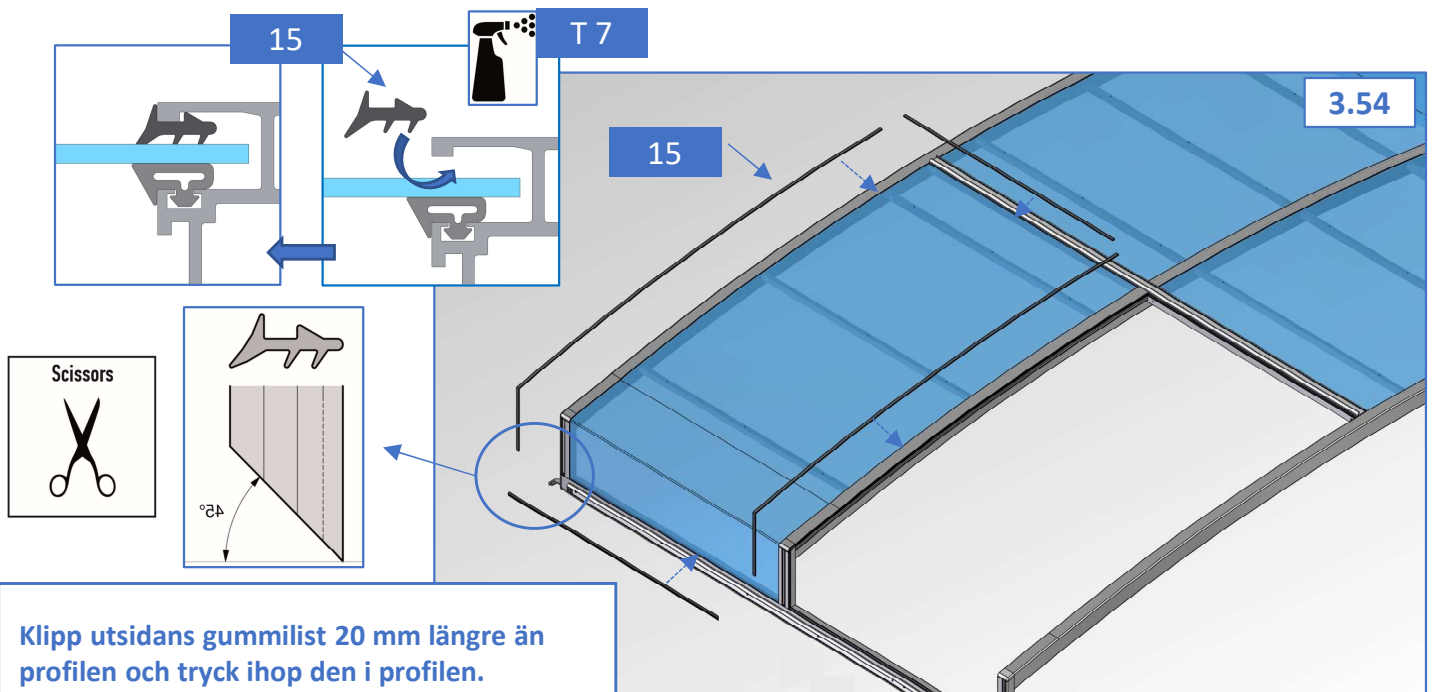

Klipp utsidans gummilist 20 mm längre än profilen och tryck ihop den i profilen.  
Upprepa denna procedur vid alla paneler

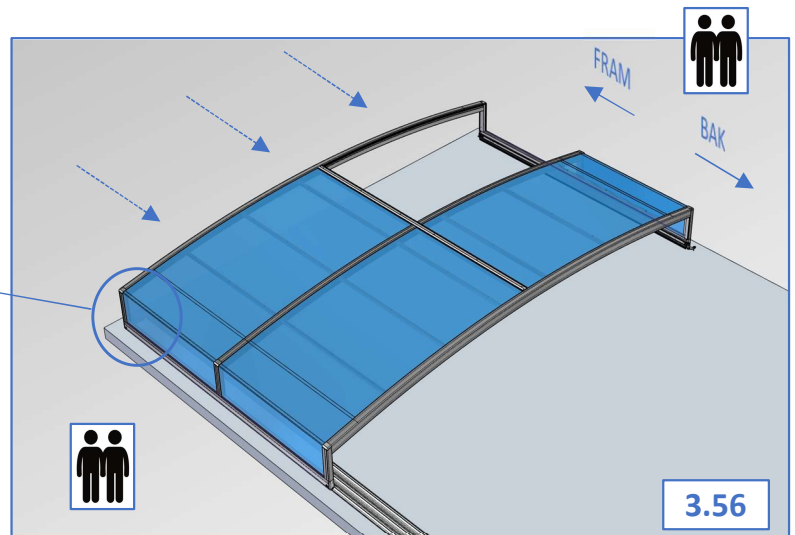
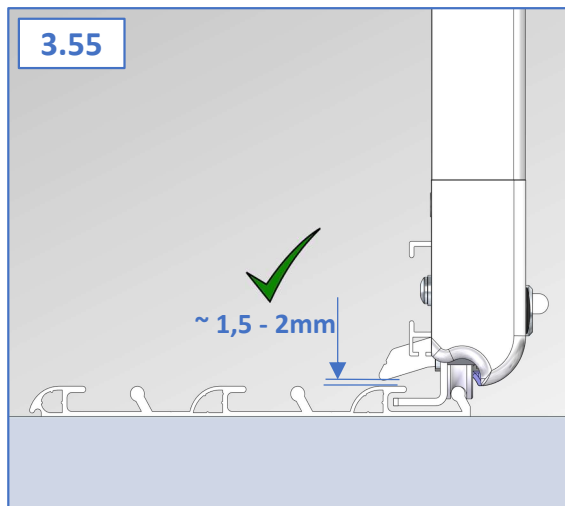



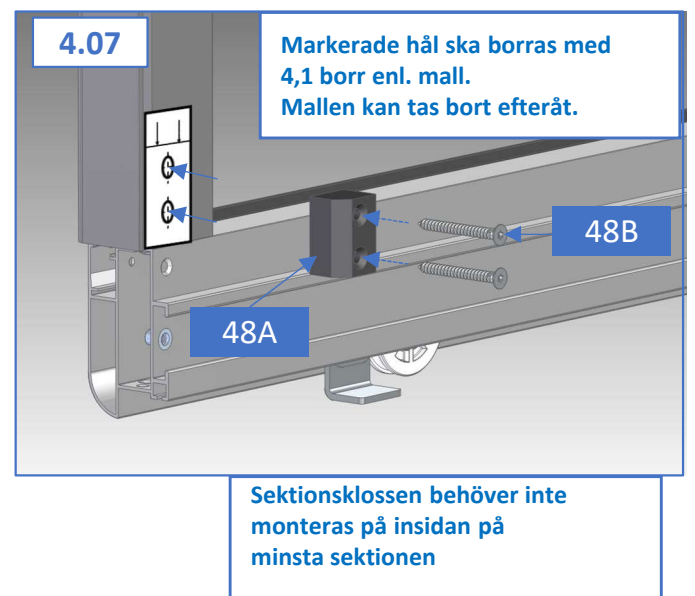
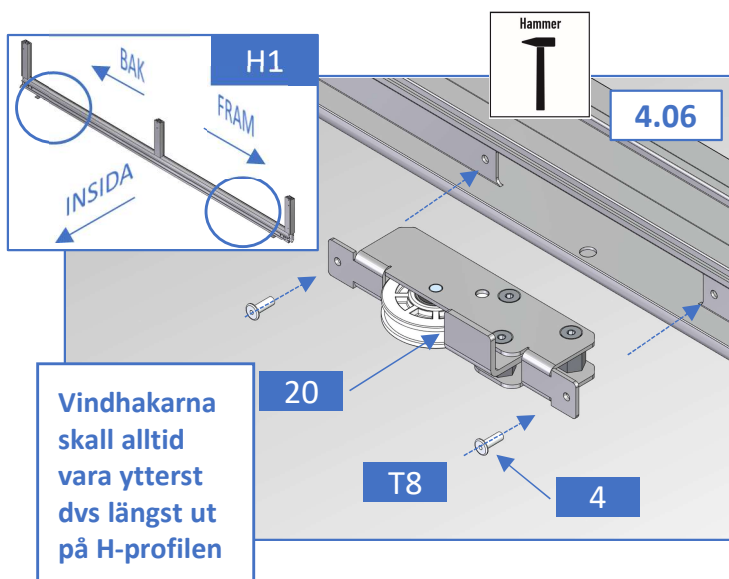
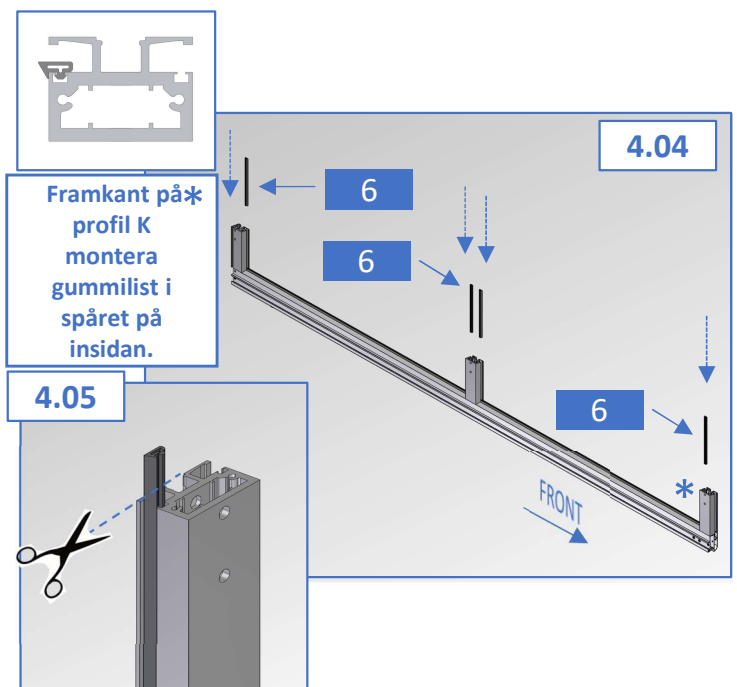
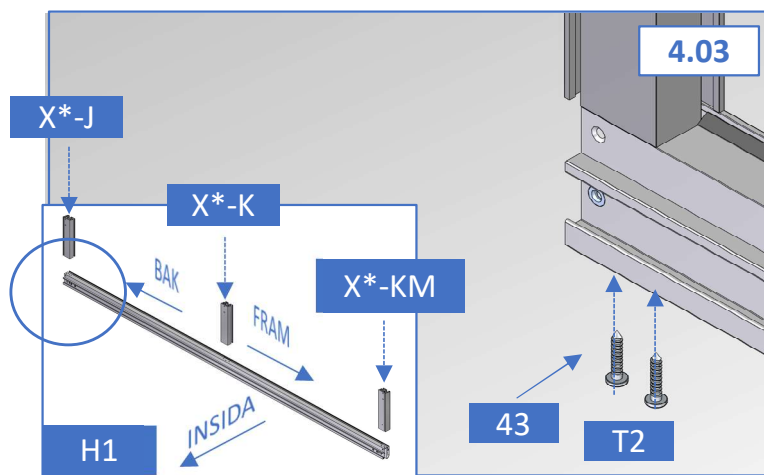
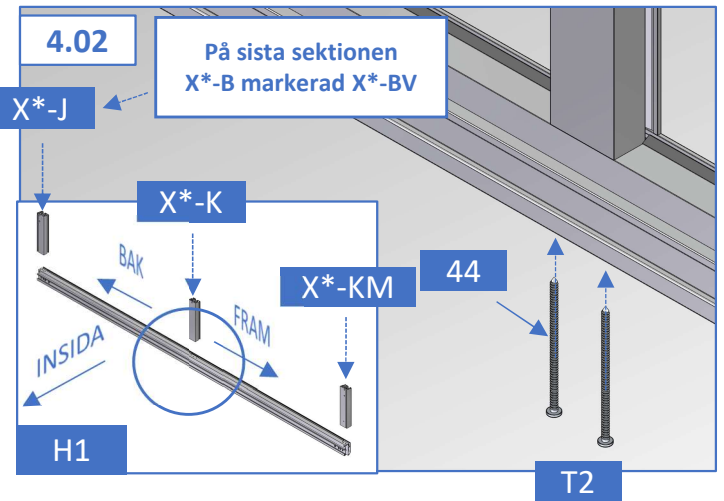
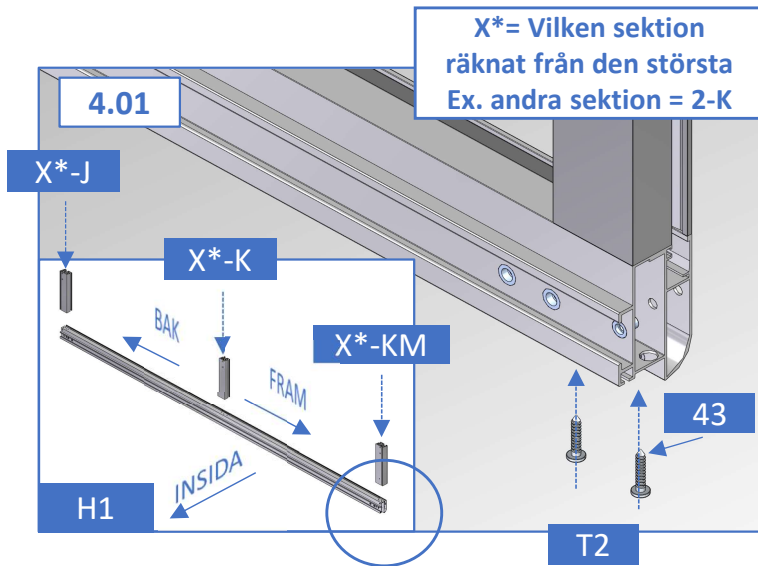

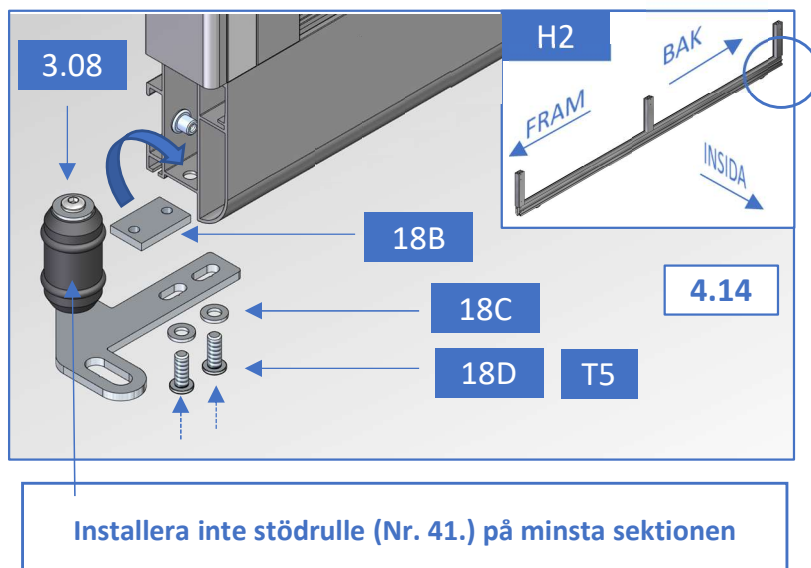
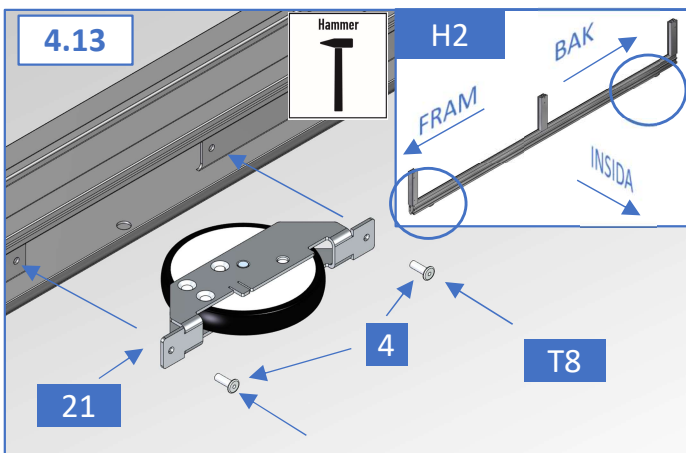
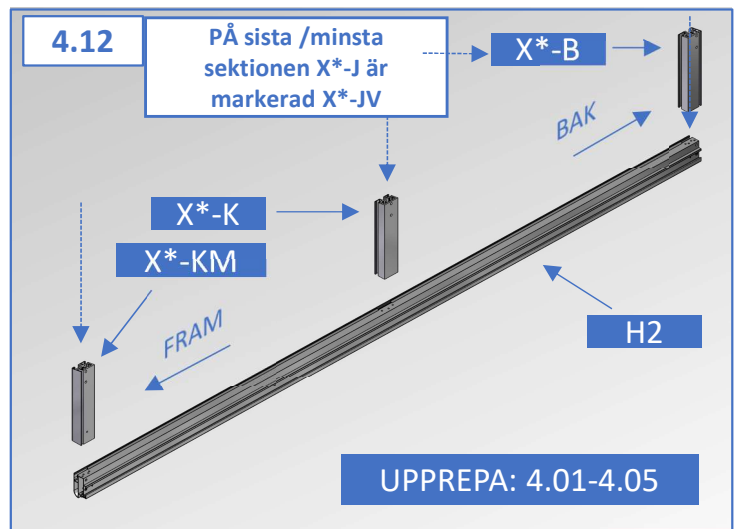
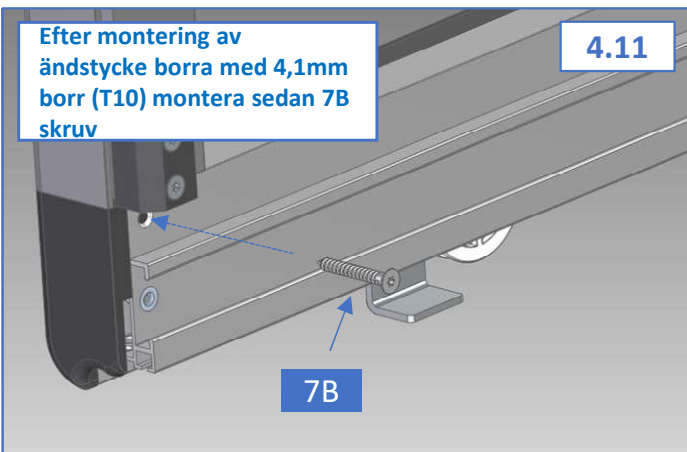
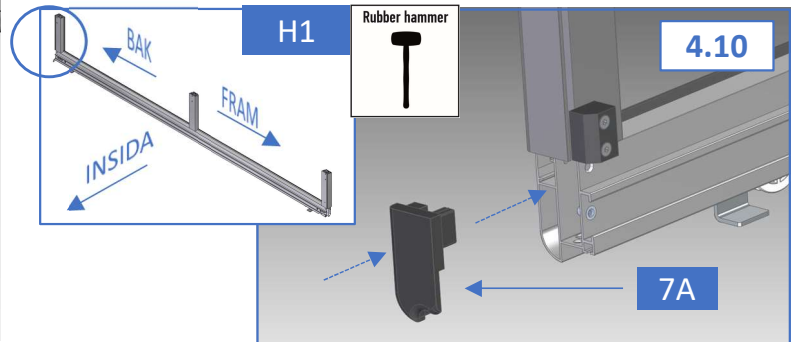
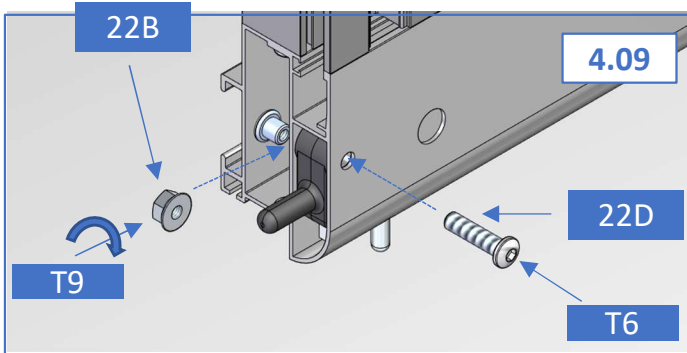
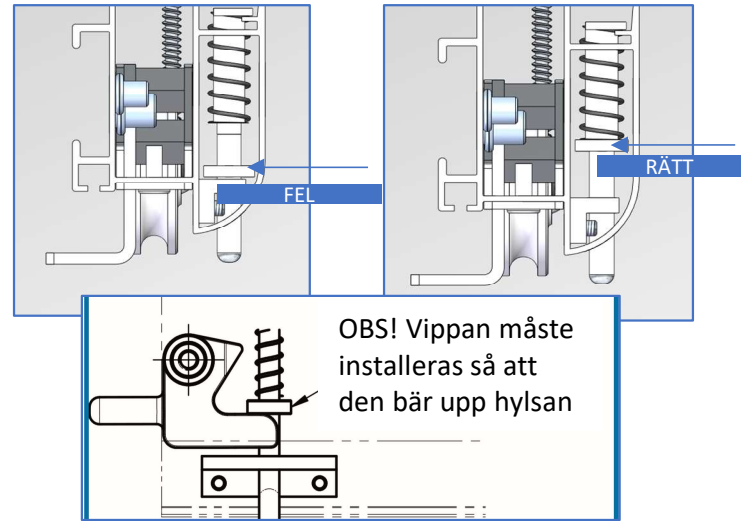
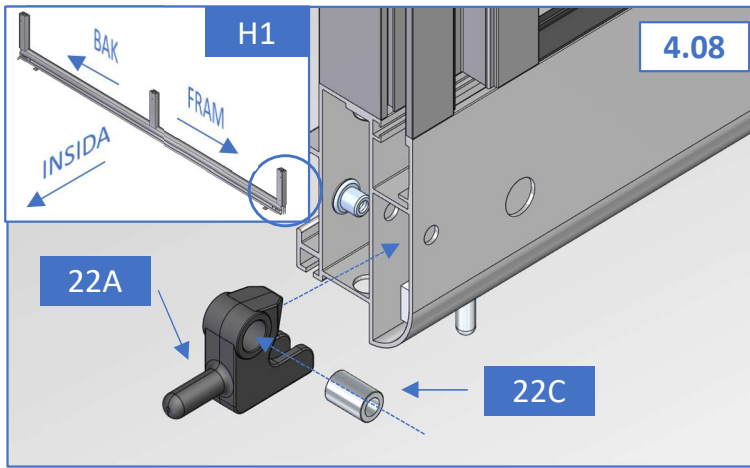

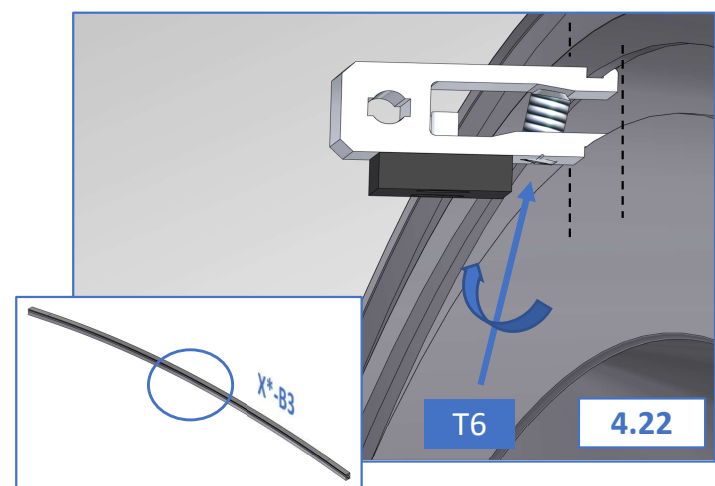
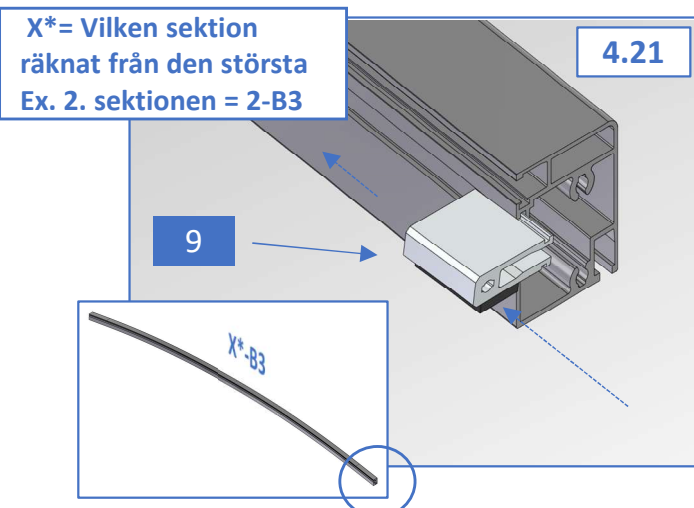
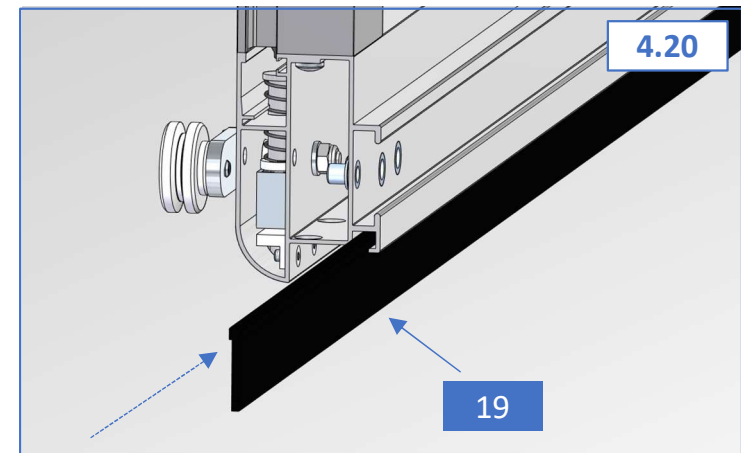
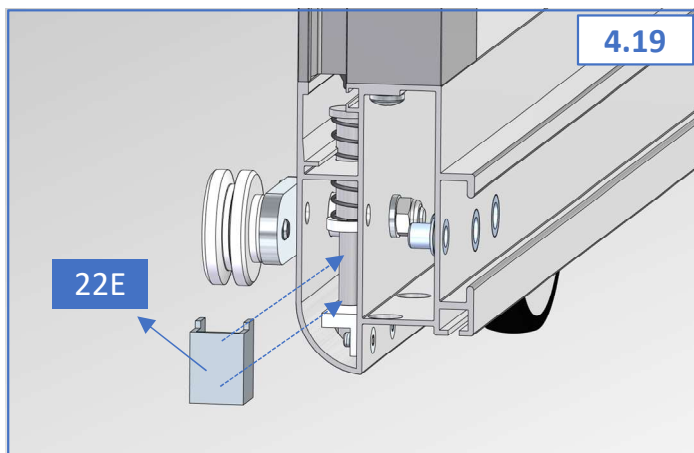
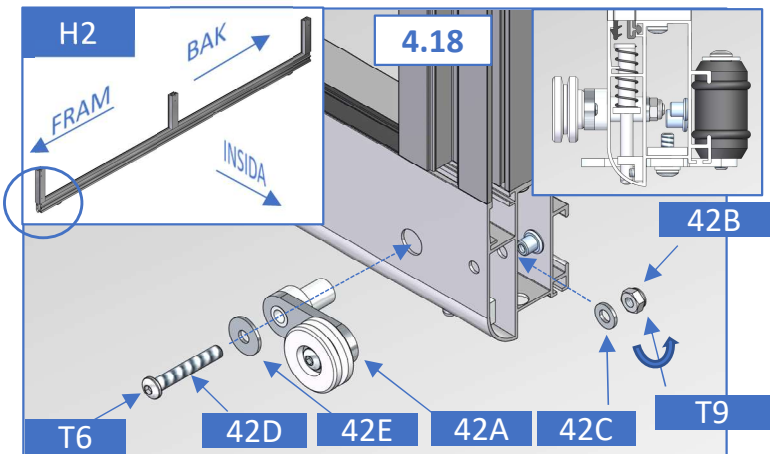
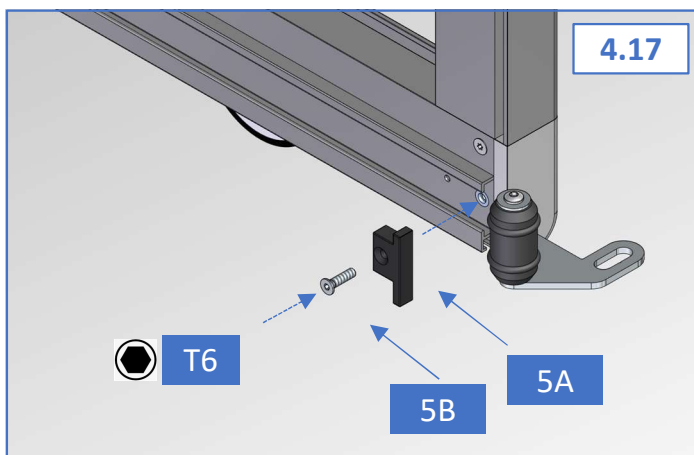
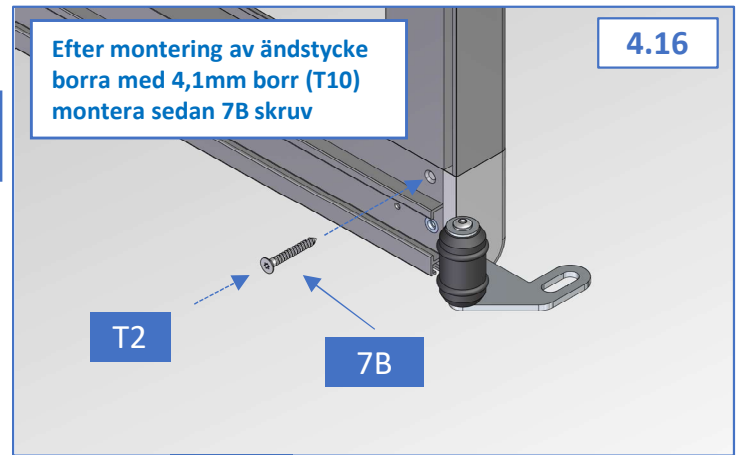
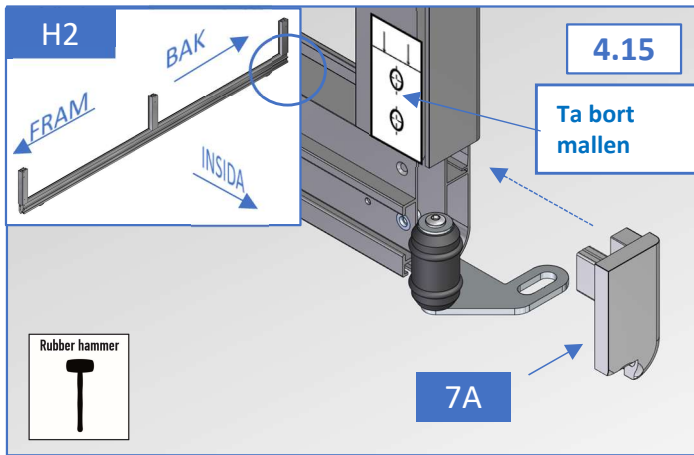



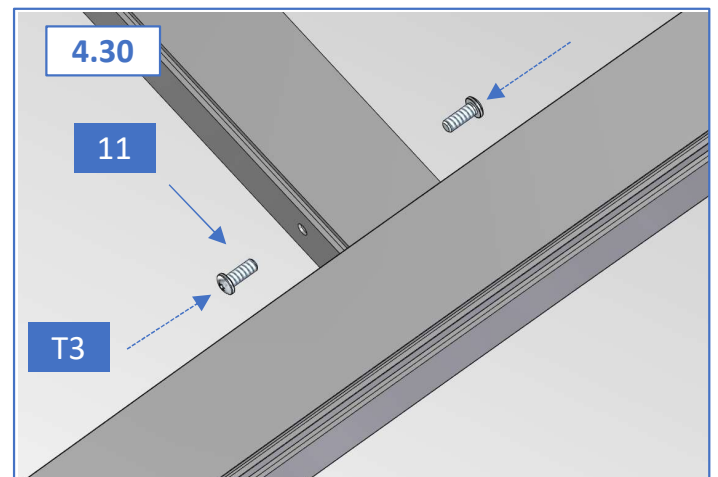
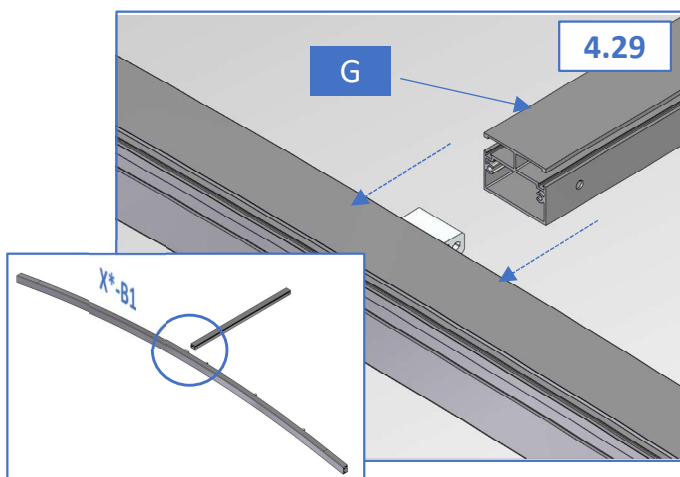
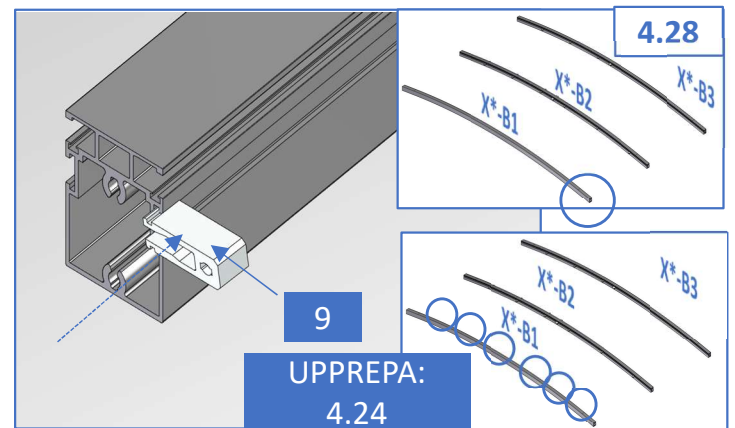
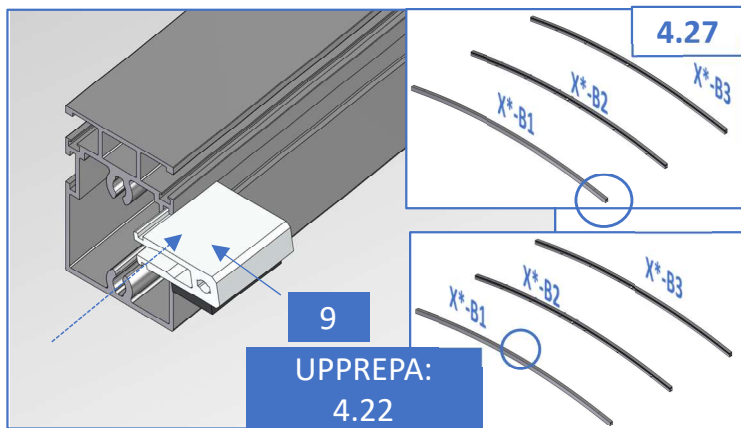
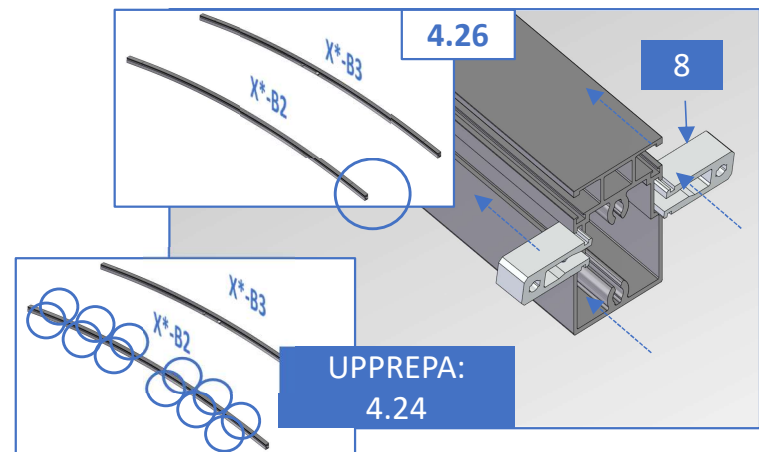
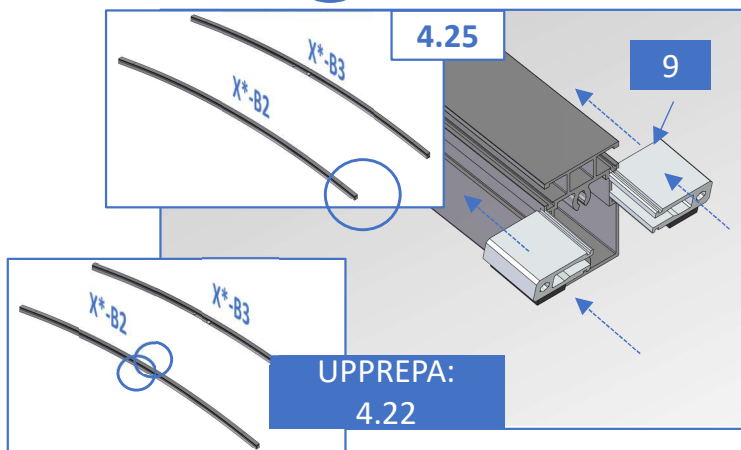
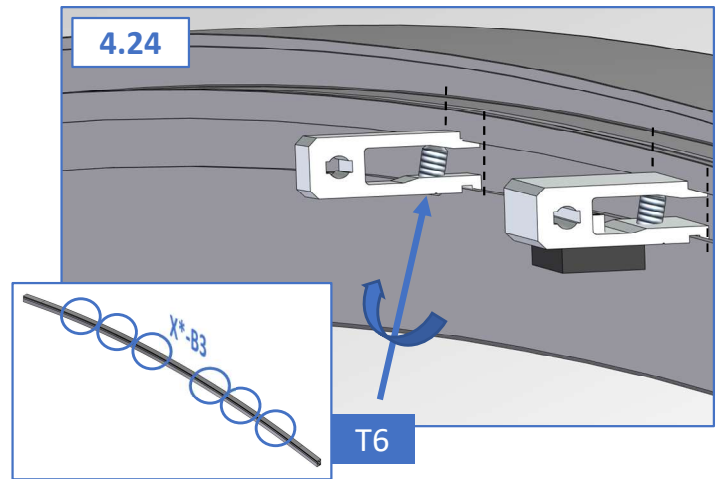
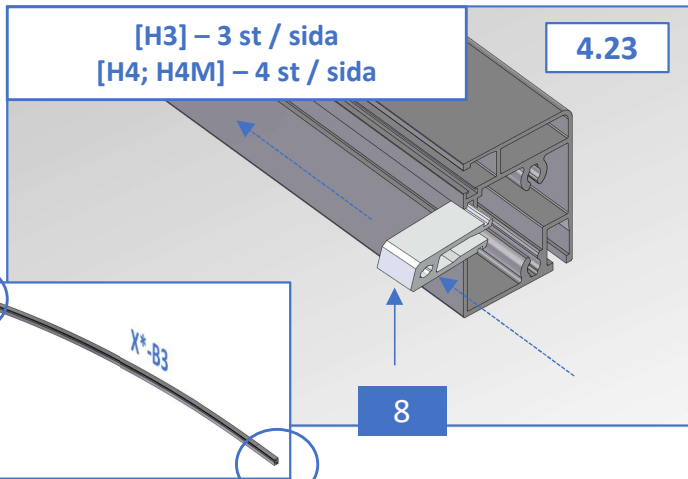

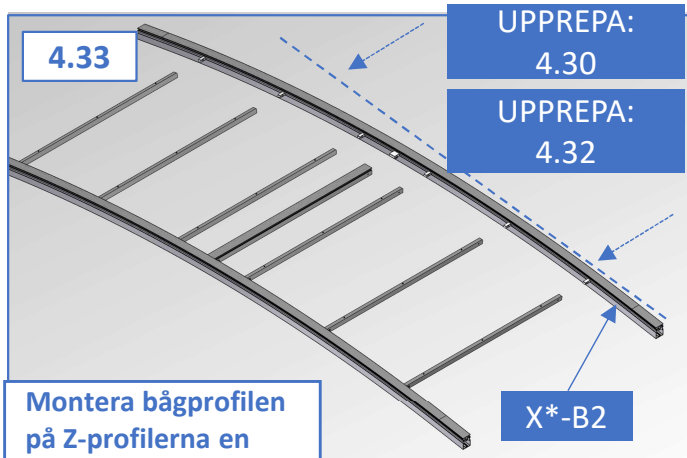
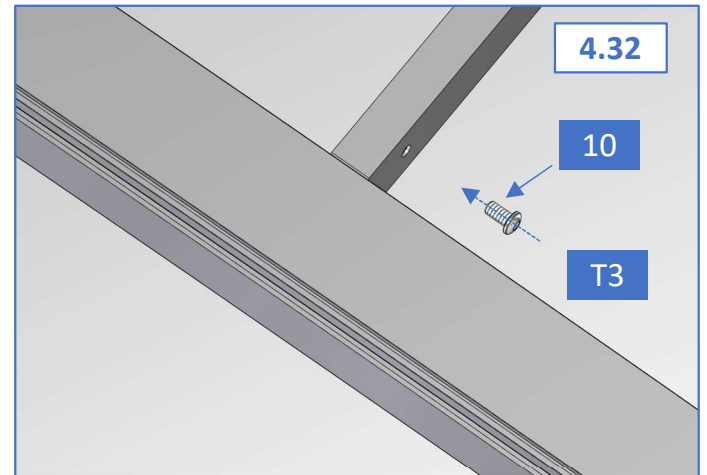
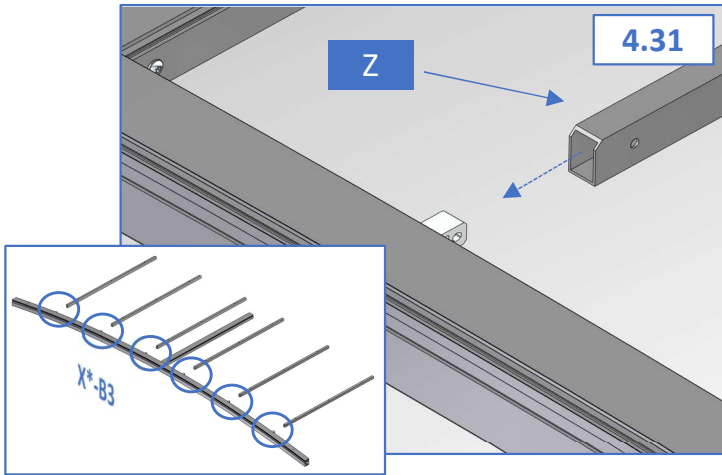

Montera bågprofilen på Z-profilerna en och en från ena änden till andra som en solfjäder. Två personer krävs.

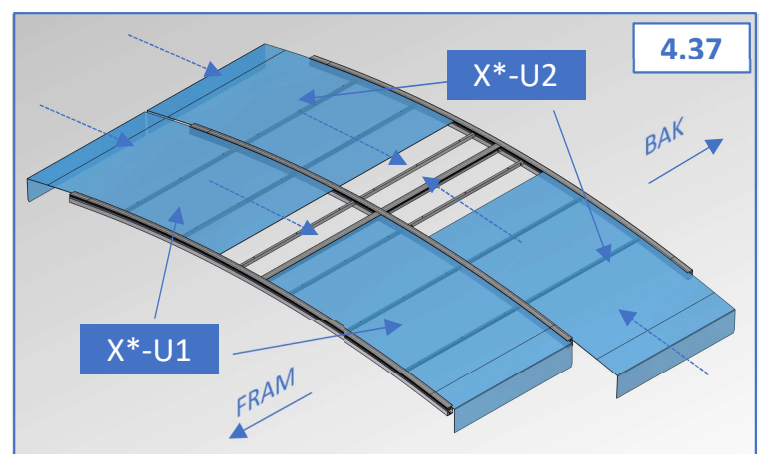
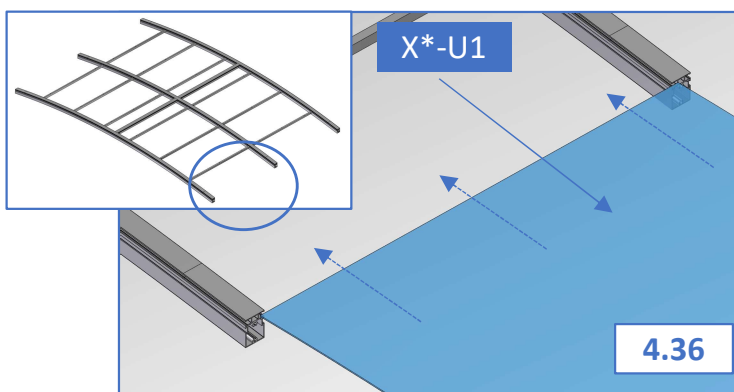
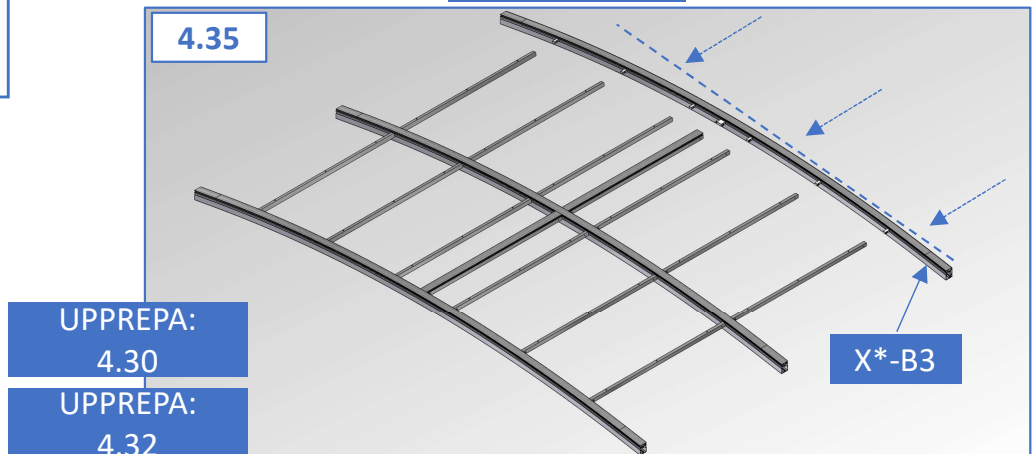
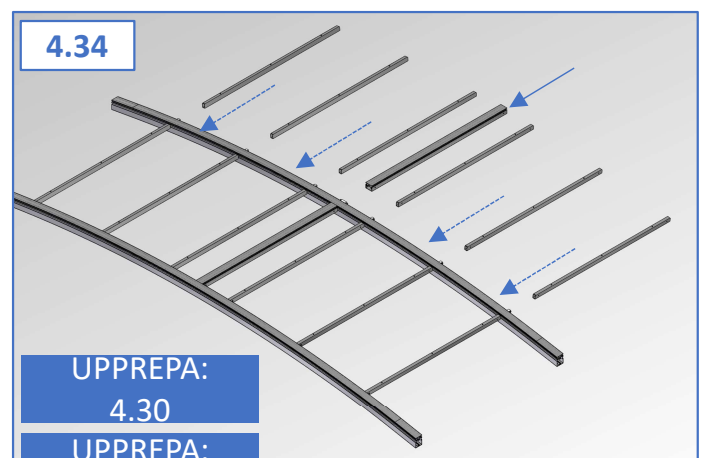

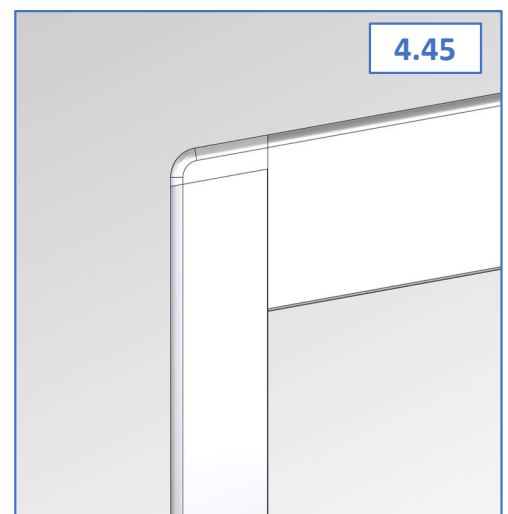
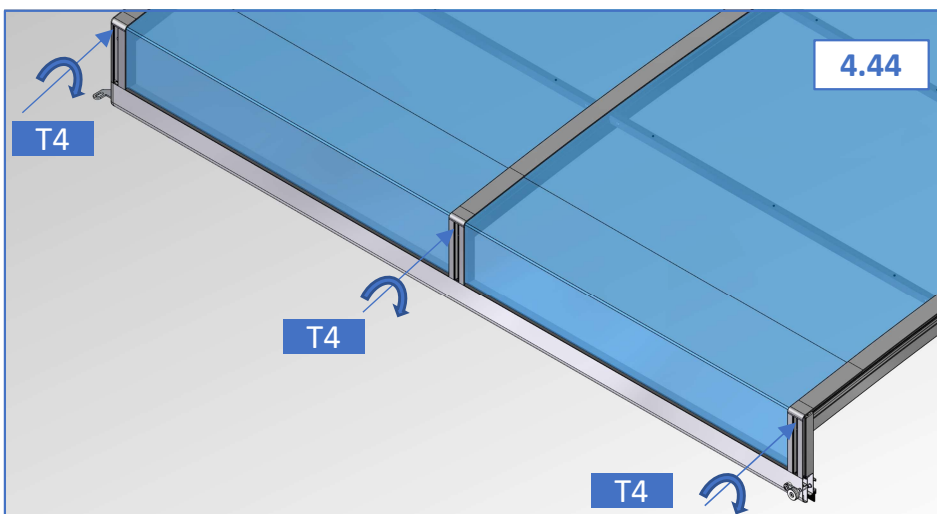
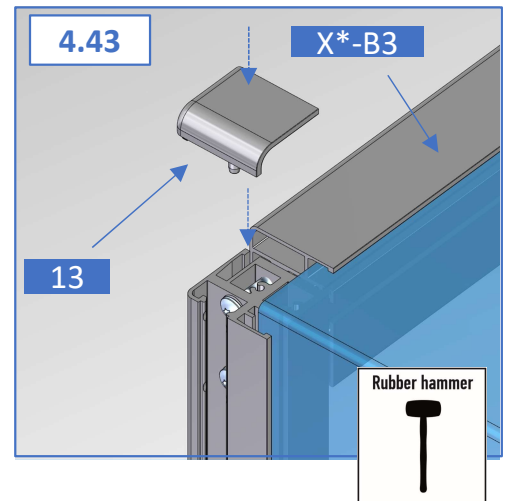
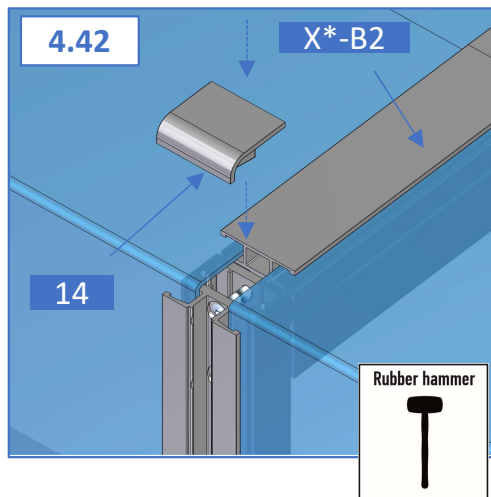
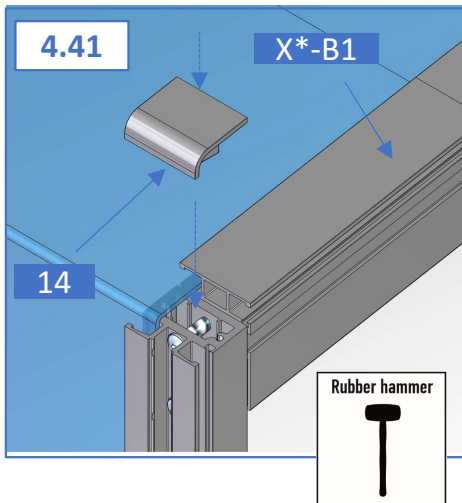
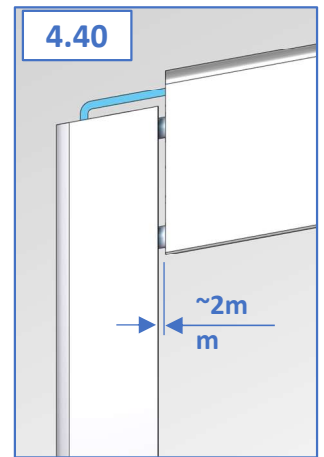
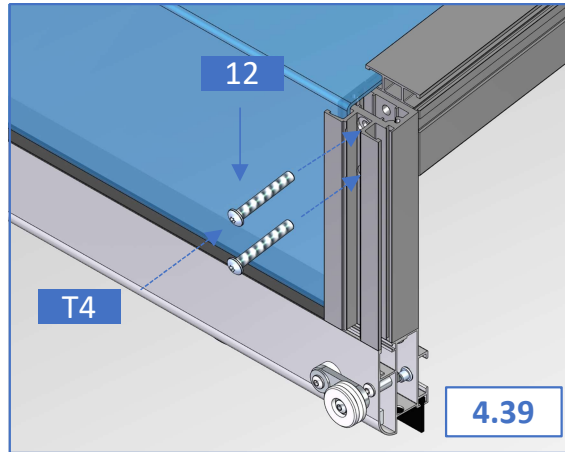
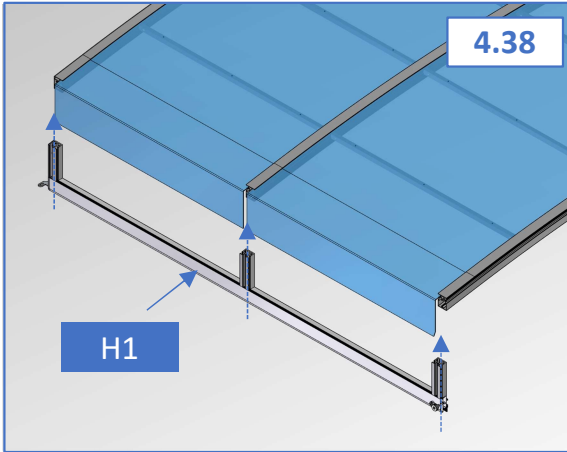



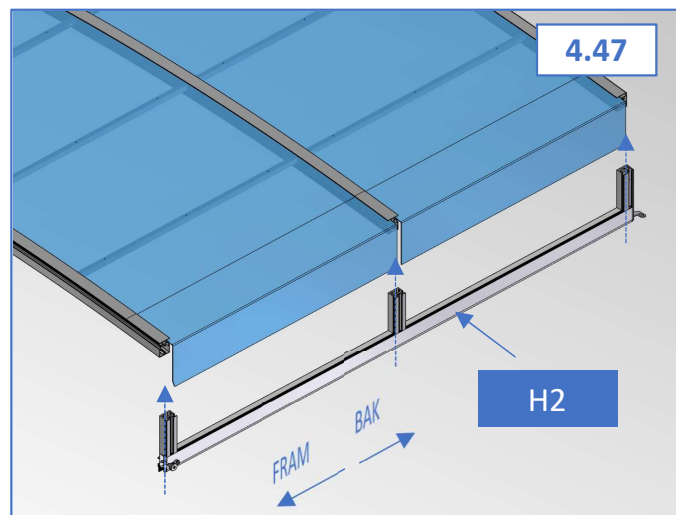
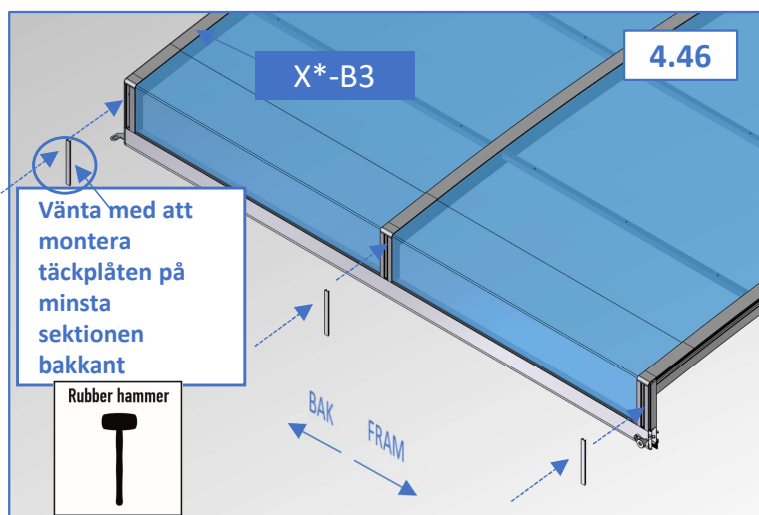

UPPREPA: 4.39 – 4.46

Montera gummilist utsida på samtliga sektioner enl bild 3.54

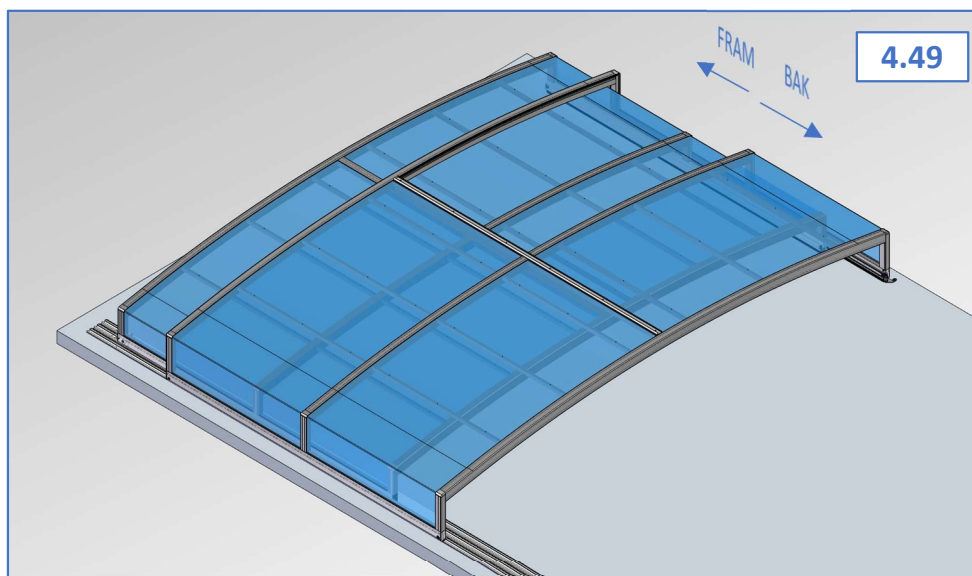
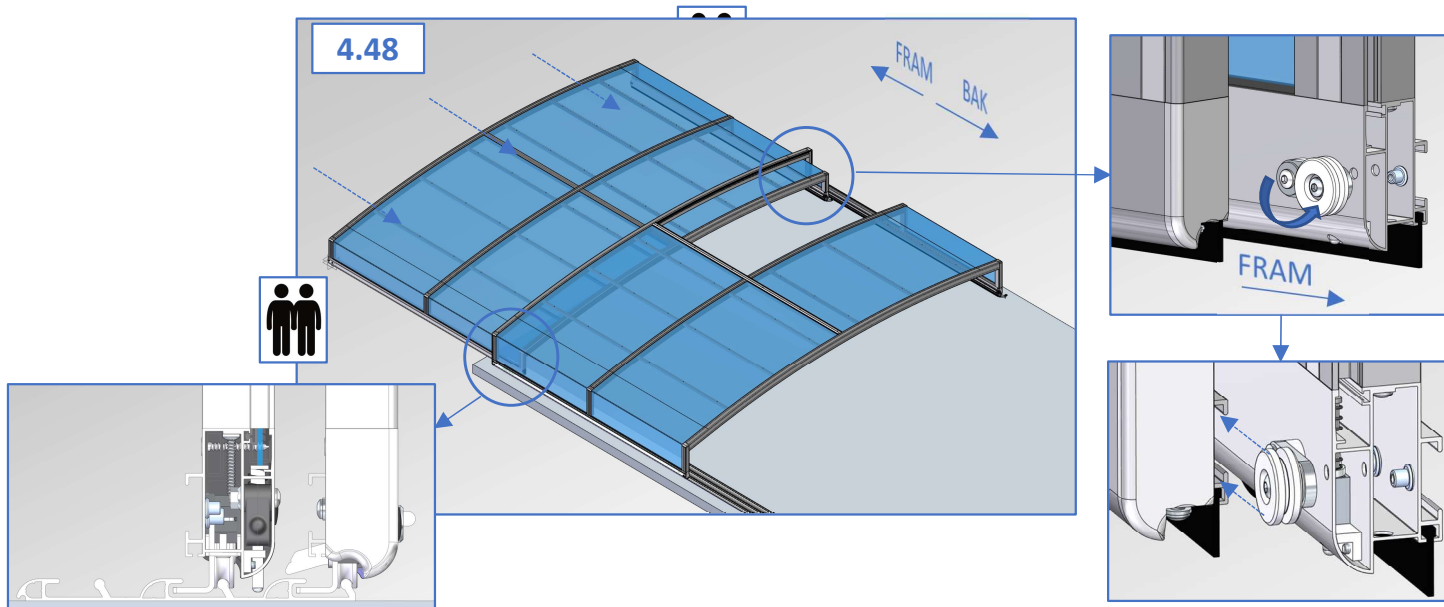

Montera samtliga mellansektioner enligt 4.01 – 4.48

Observera följande punkter vid montering av den minsta sektionen 4.02, 4.07, 4.14, 4.46.

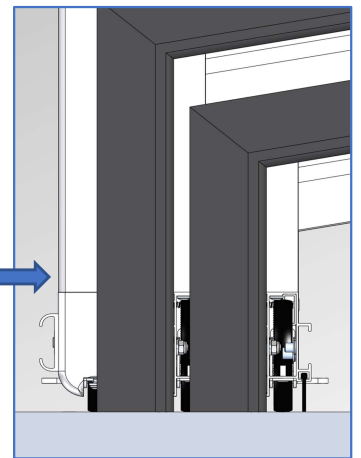
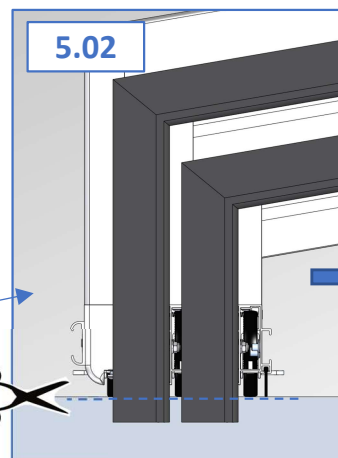
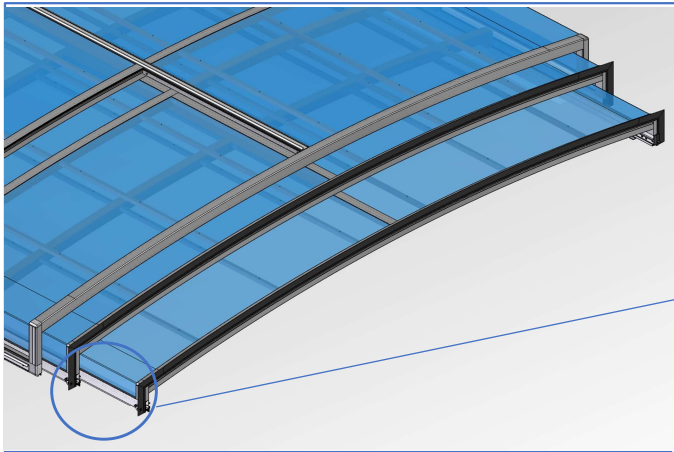
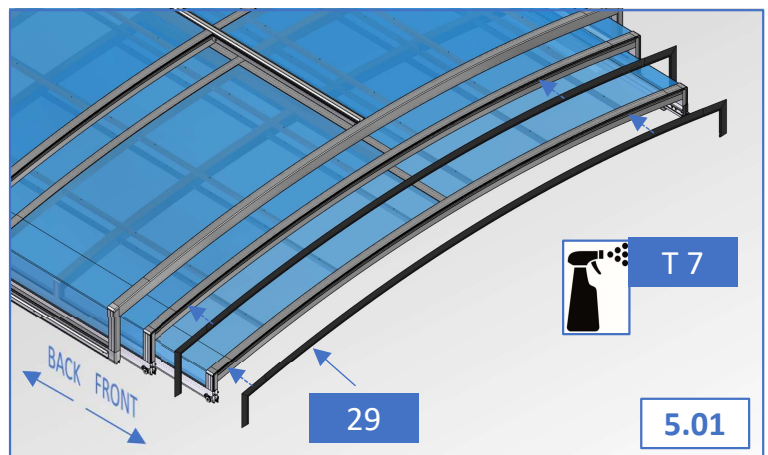
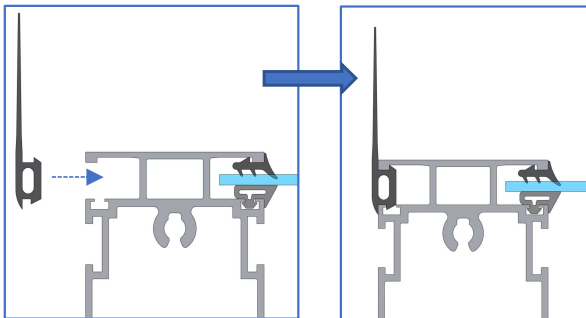
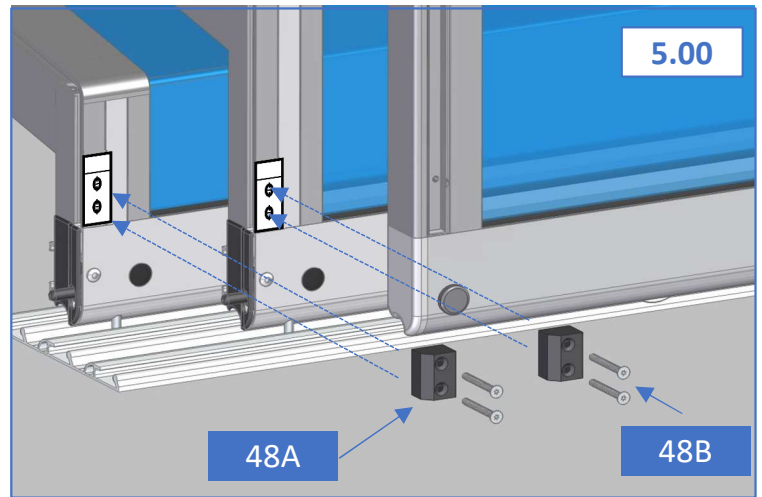
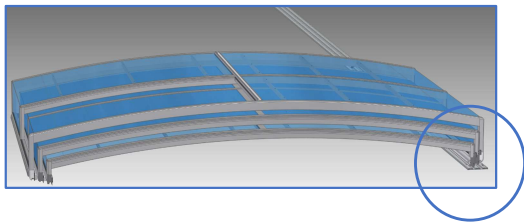

Gör en liten  
rundning i hörnan  
för att minska  
gummits slitage.

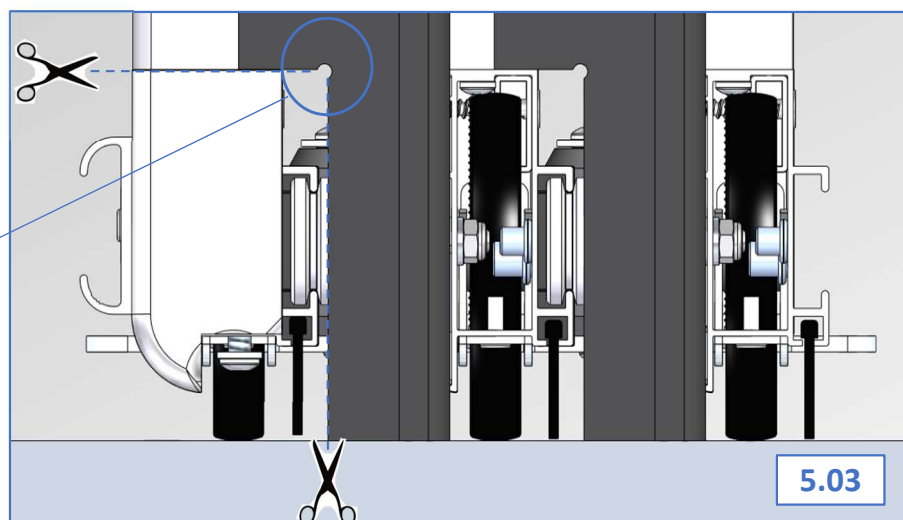

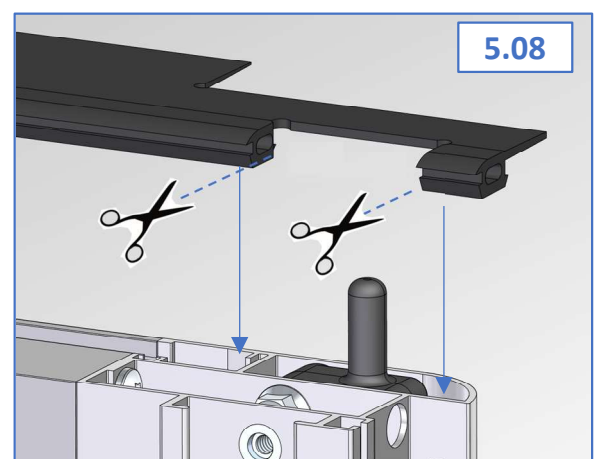
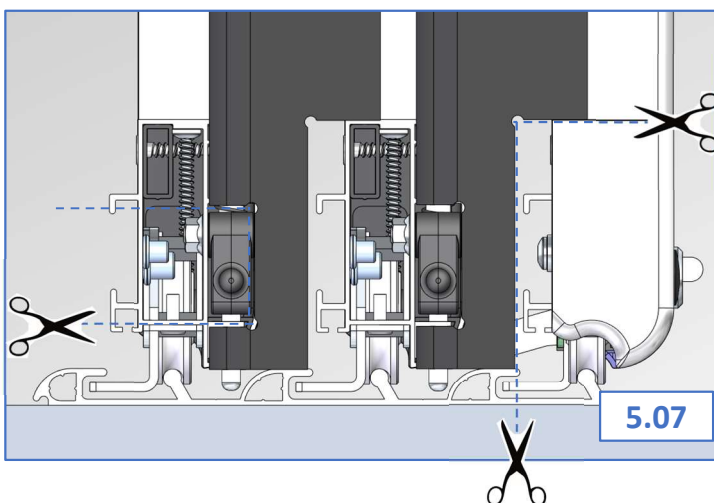
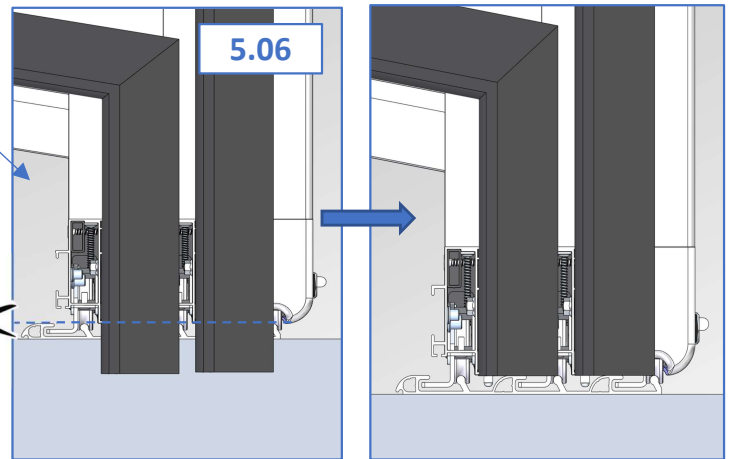
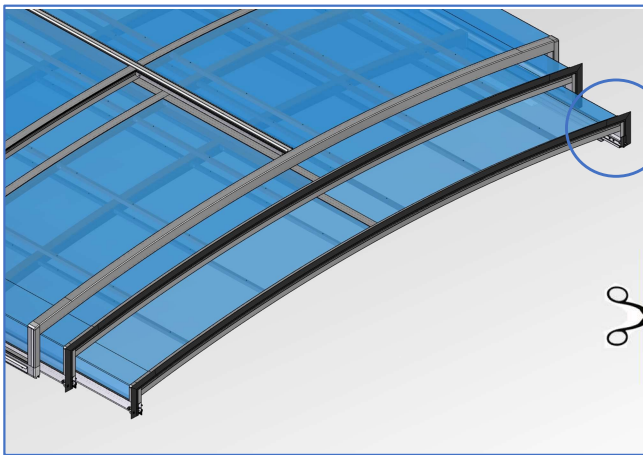
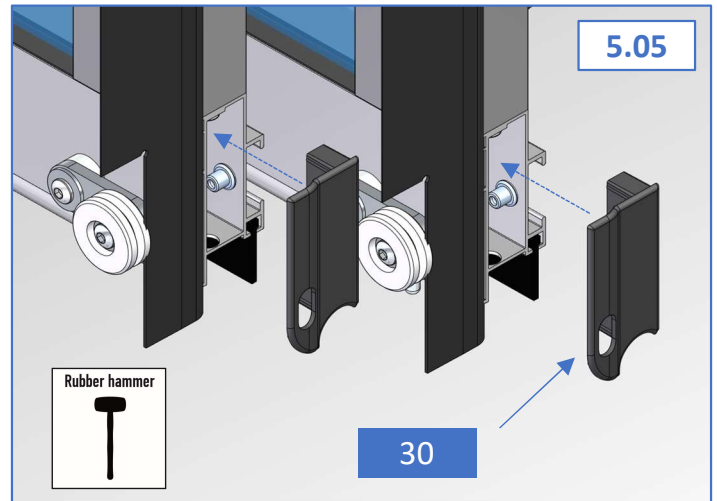
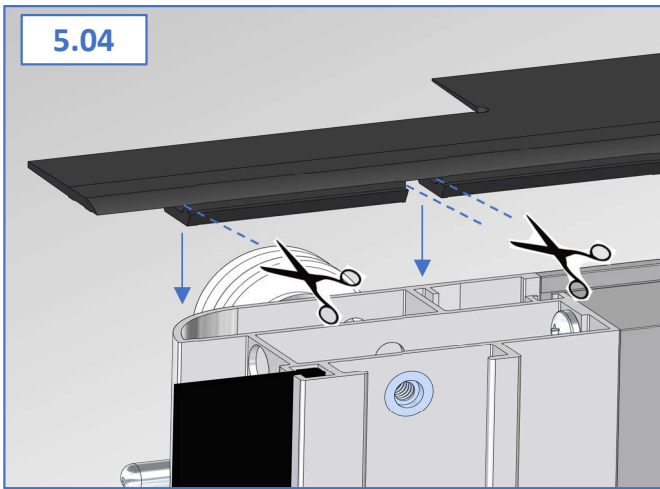



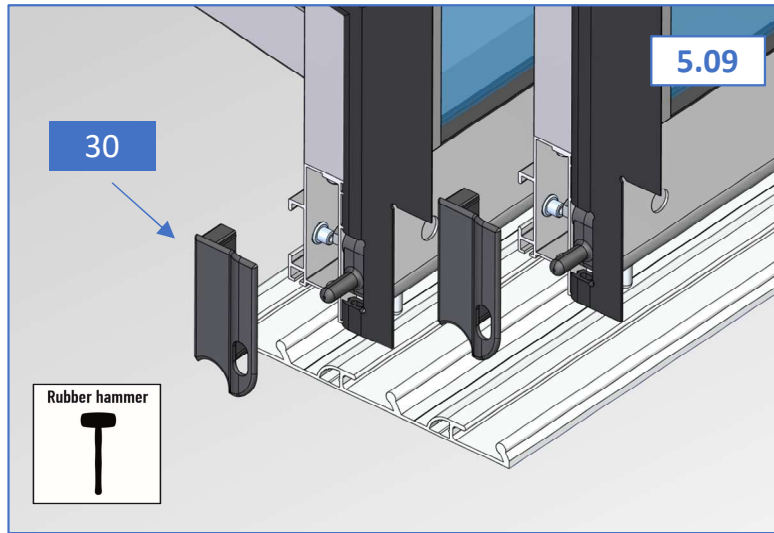

Låsbeslag (Nr.31.) ska inte monteras på minsta sektionen

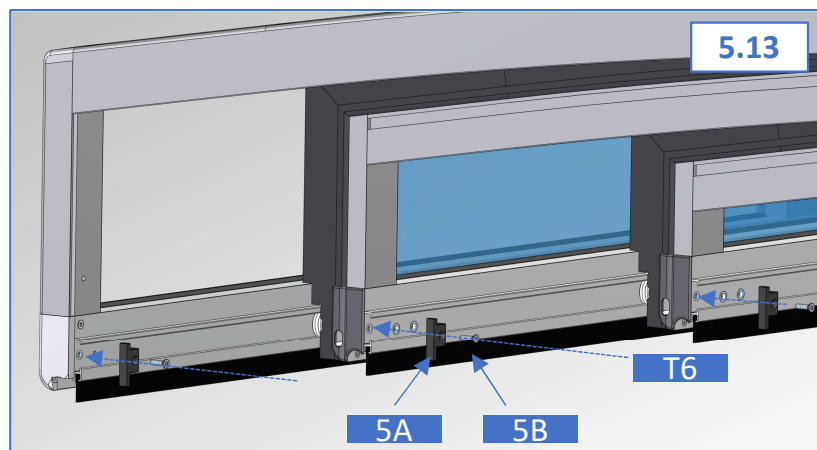
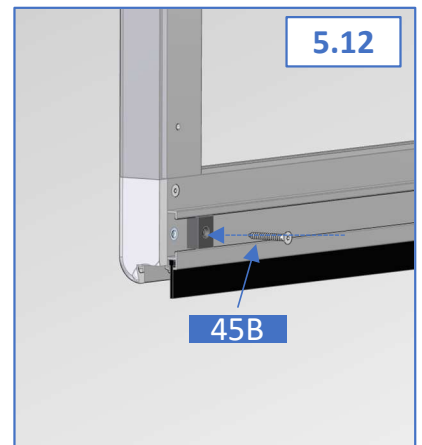
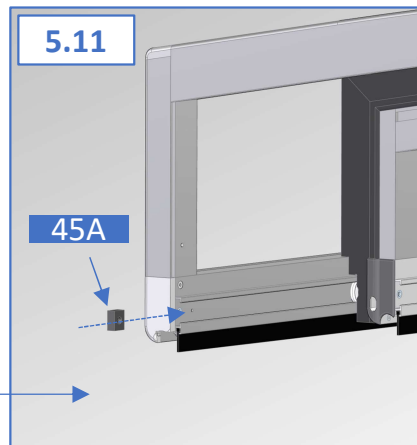
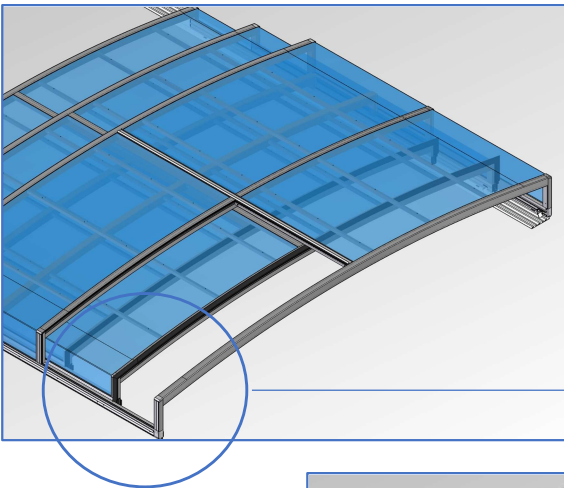
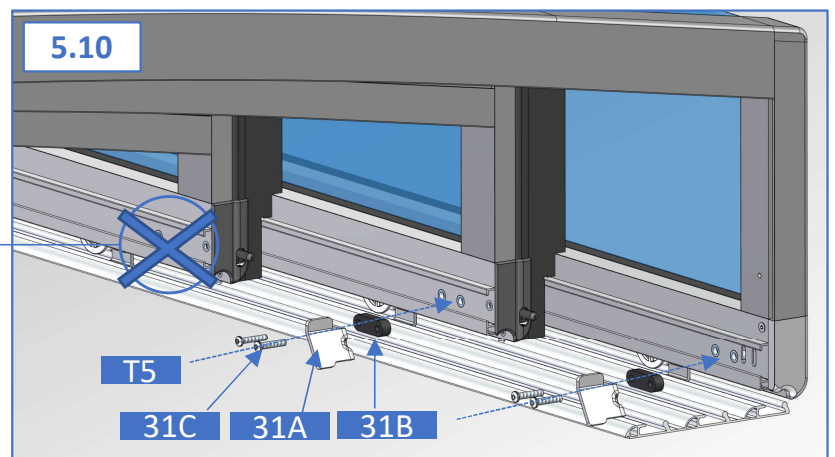

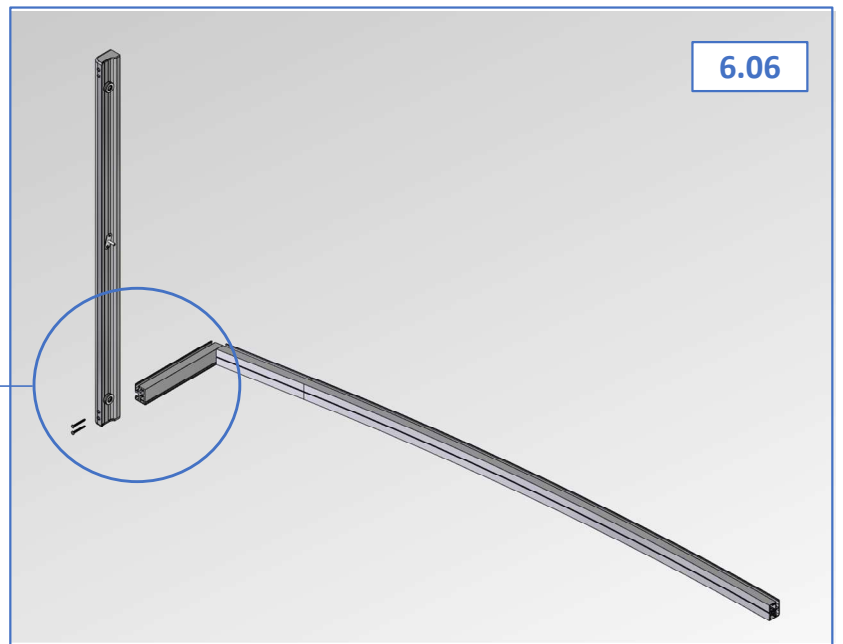
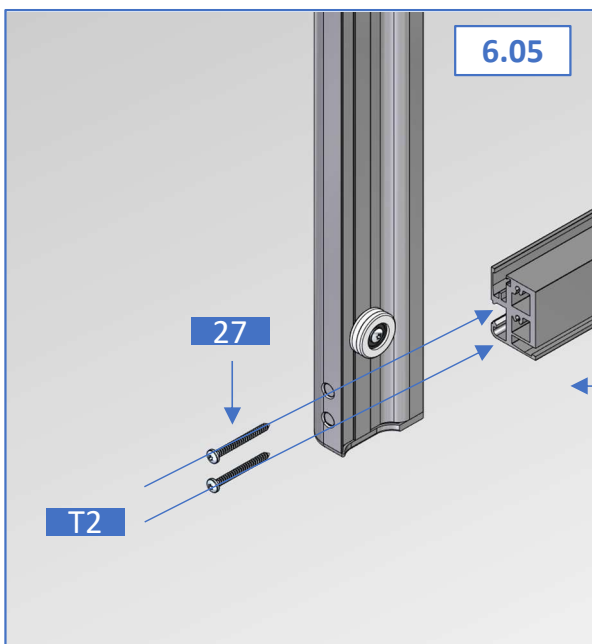
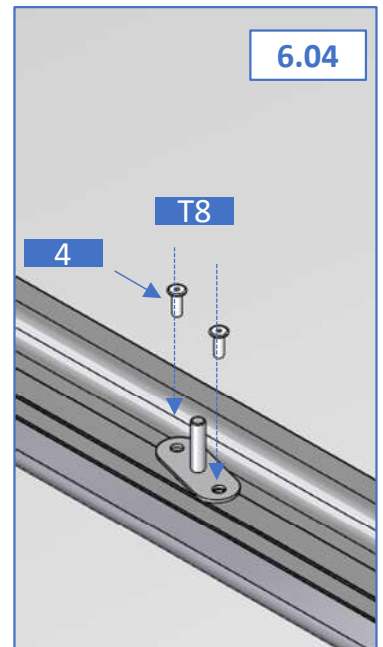
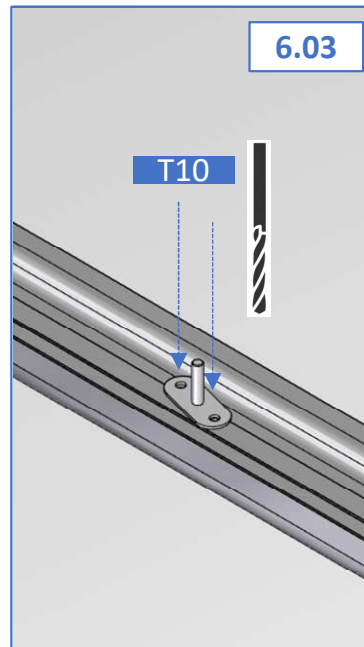
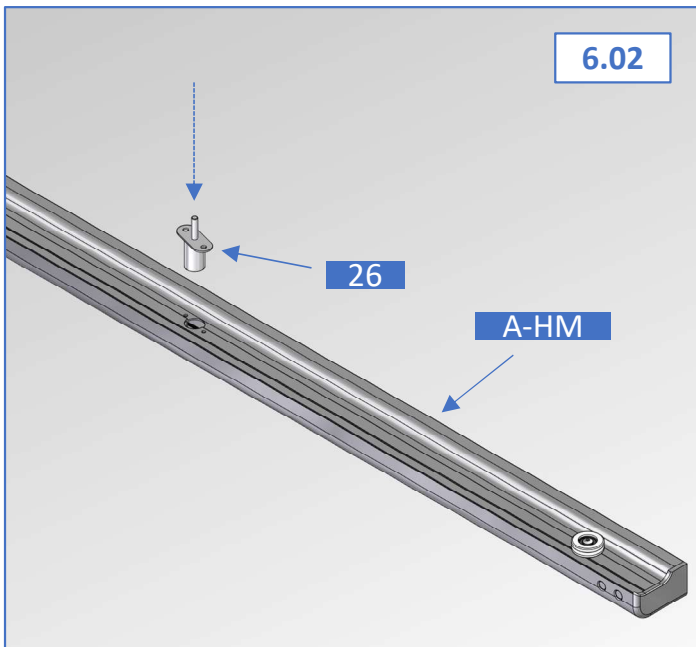
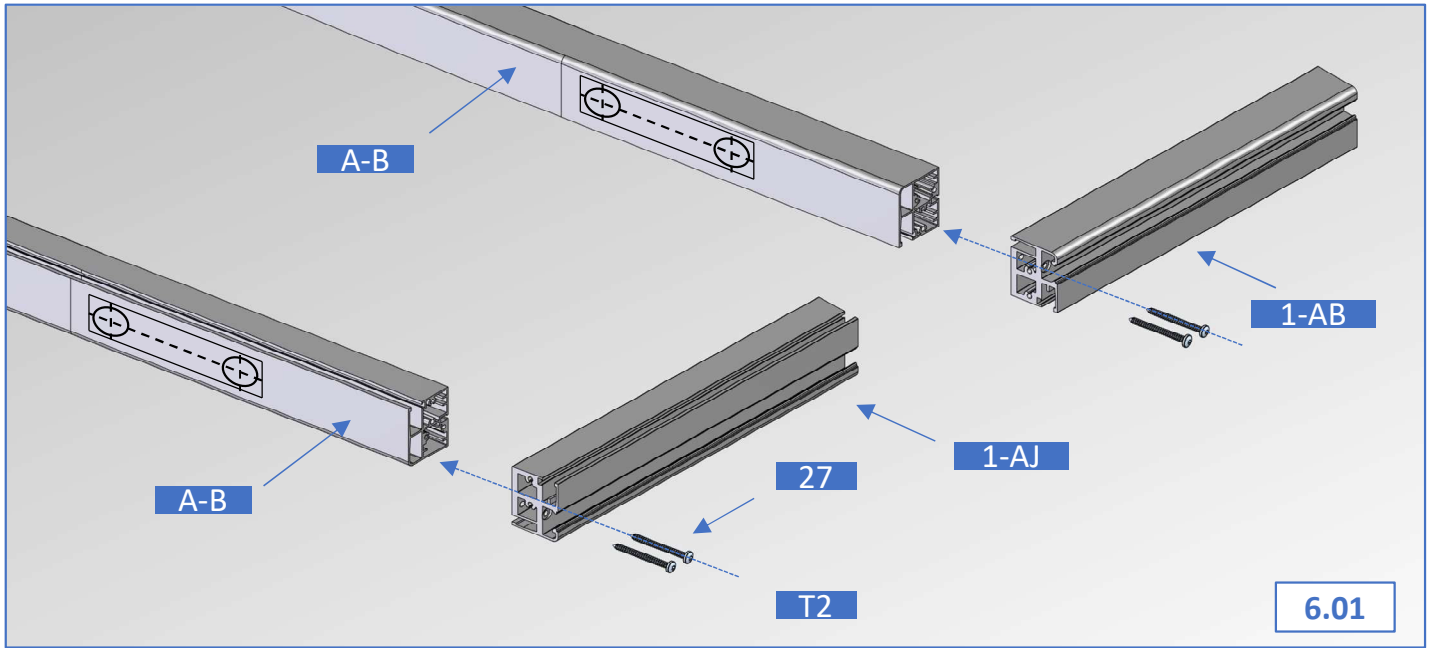

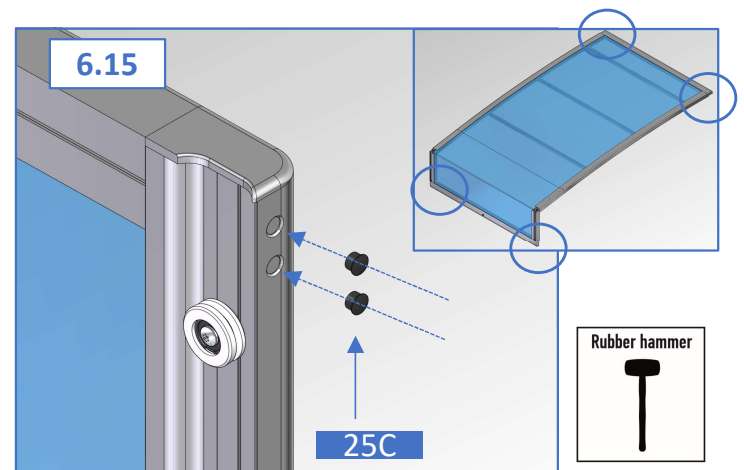
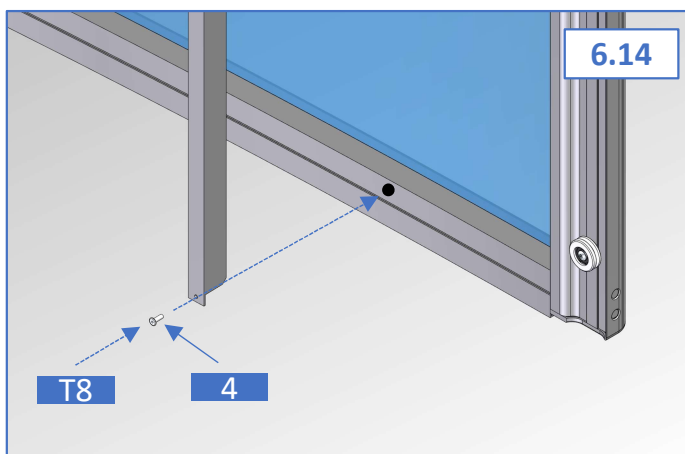
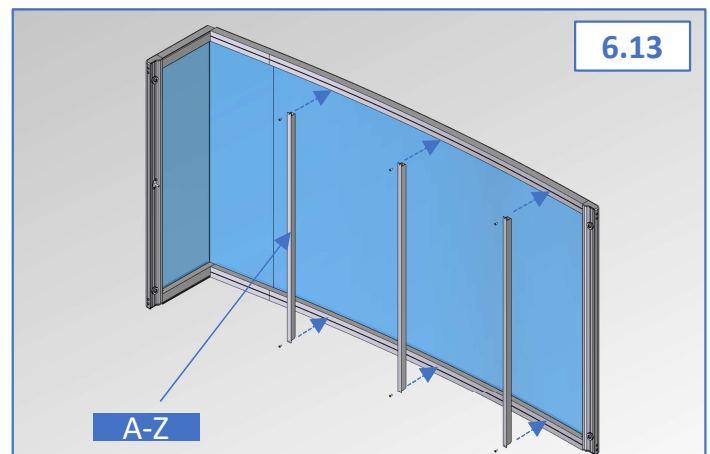
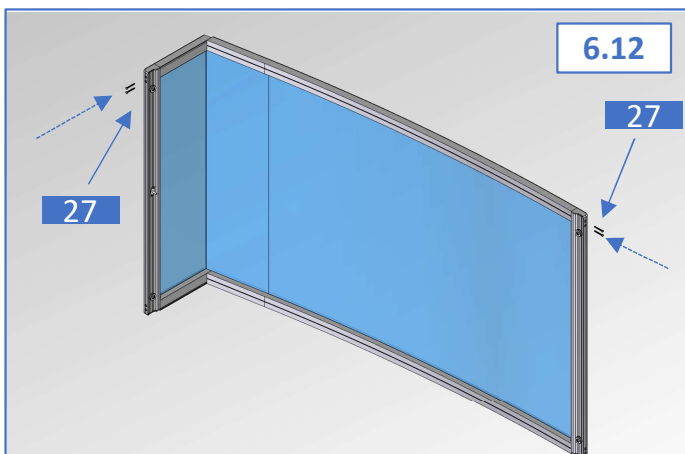
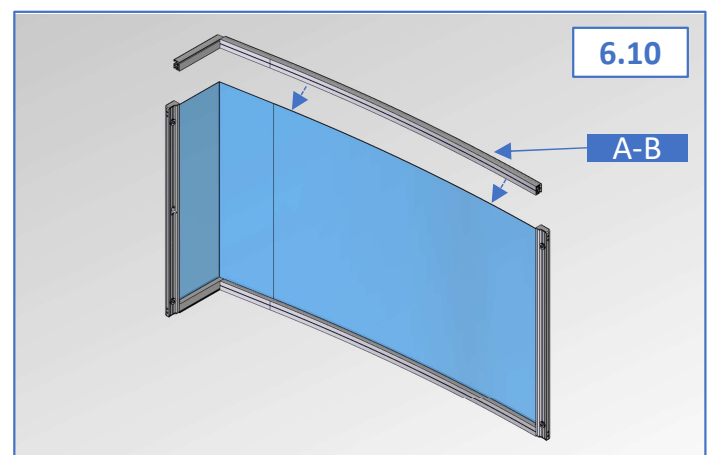
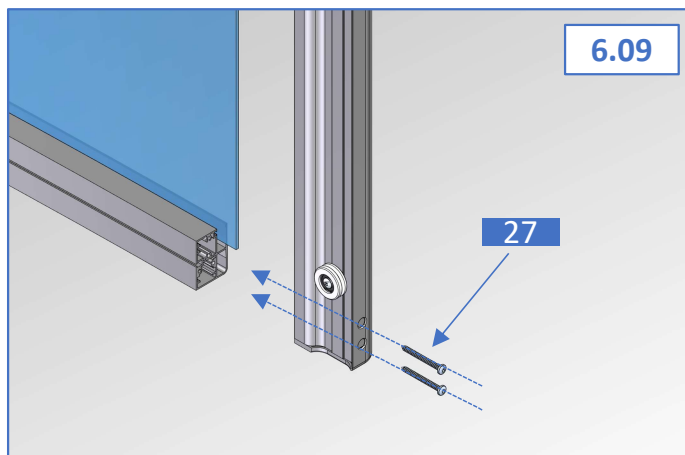
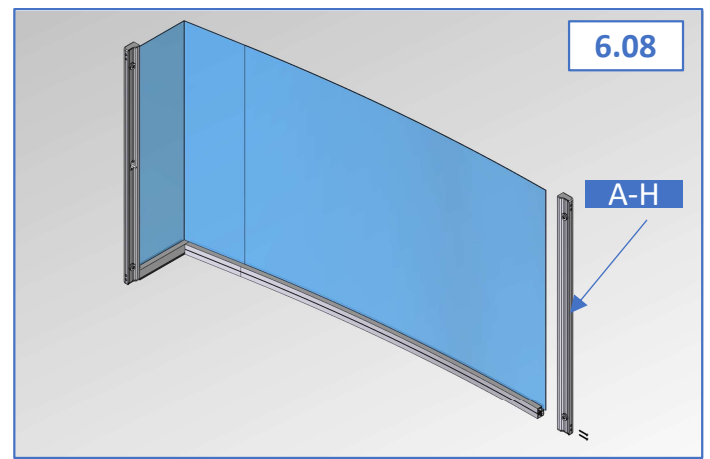
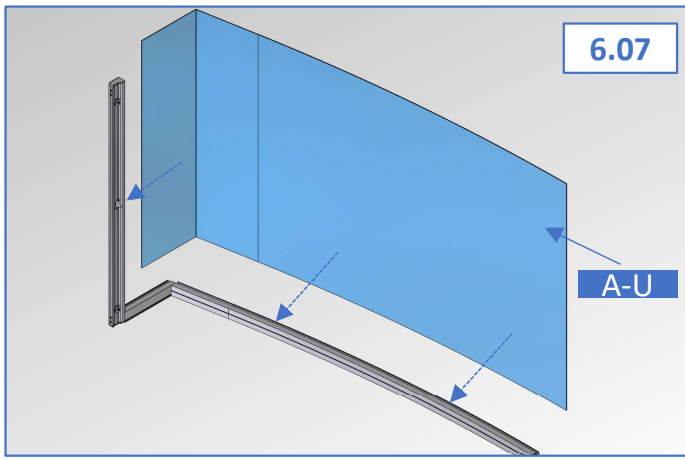



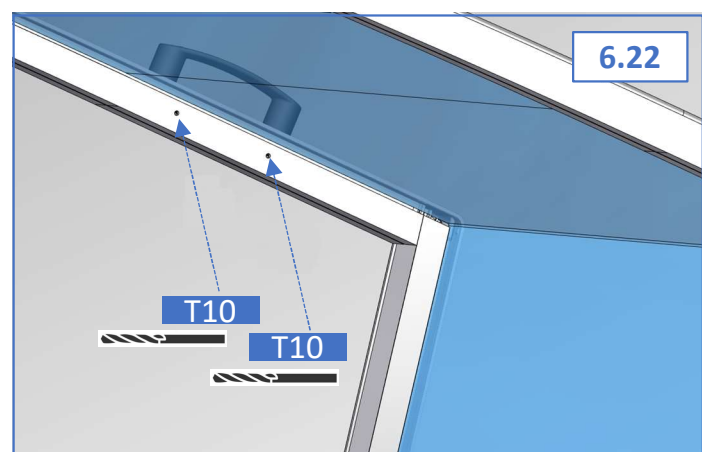
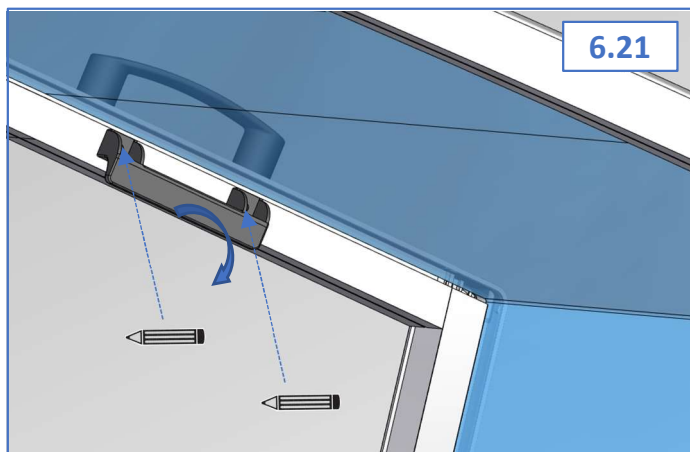
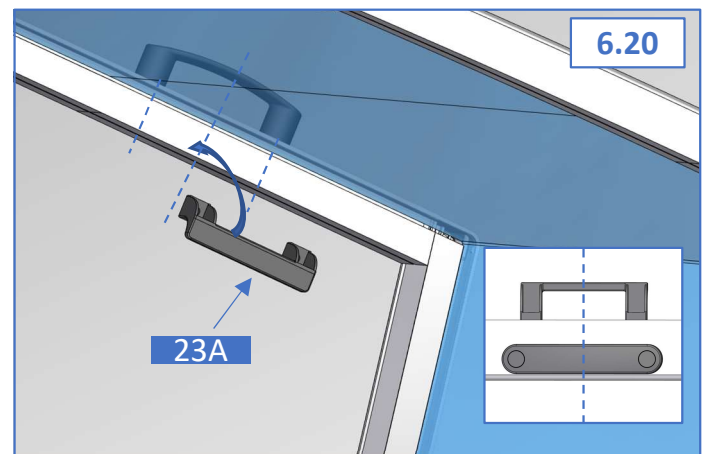
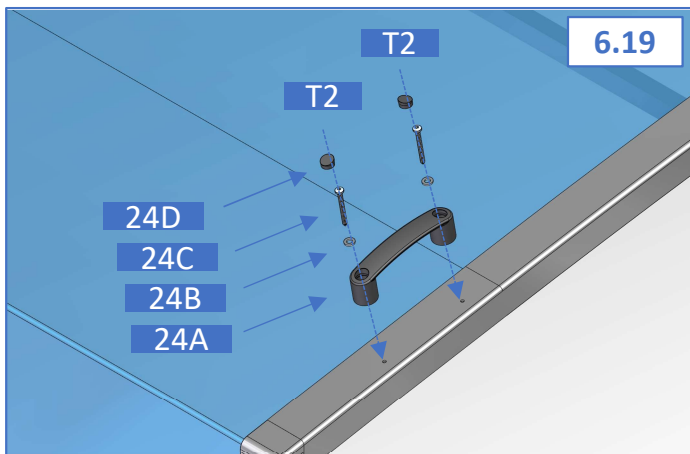
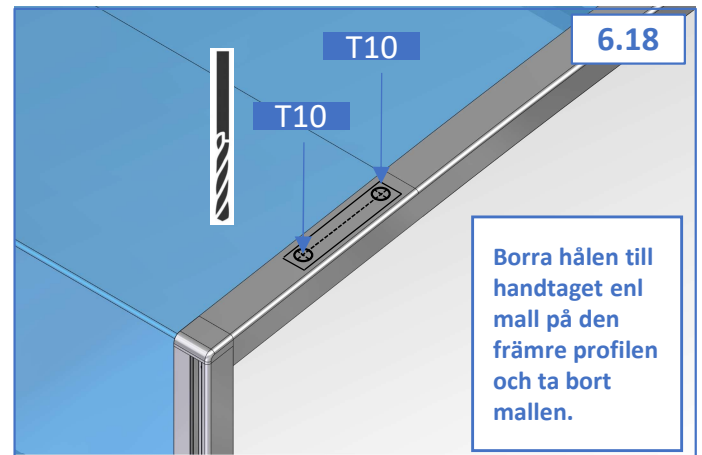
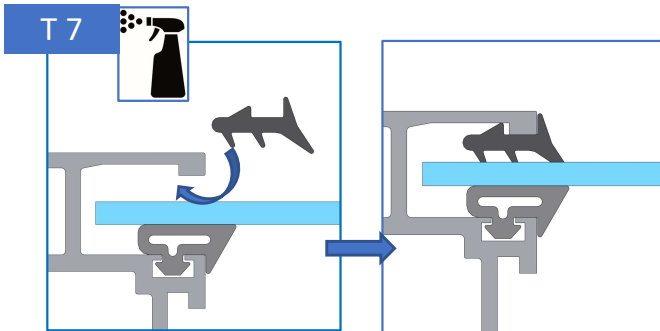
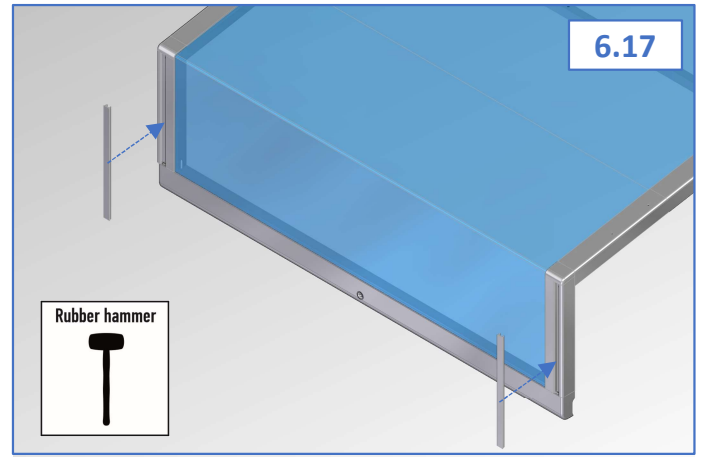
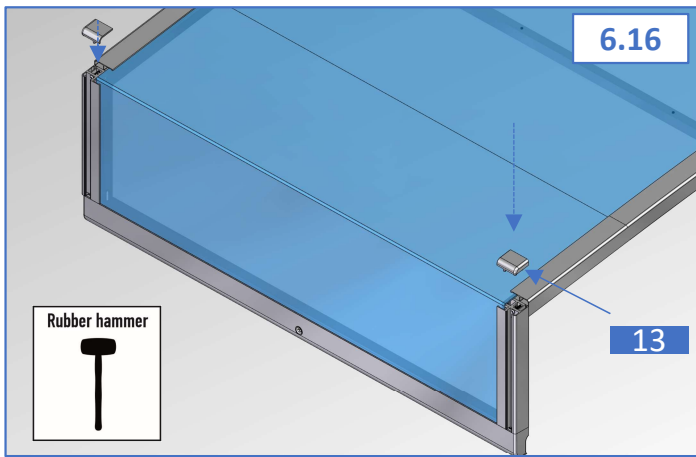

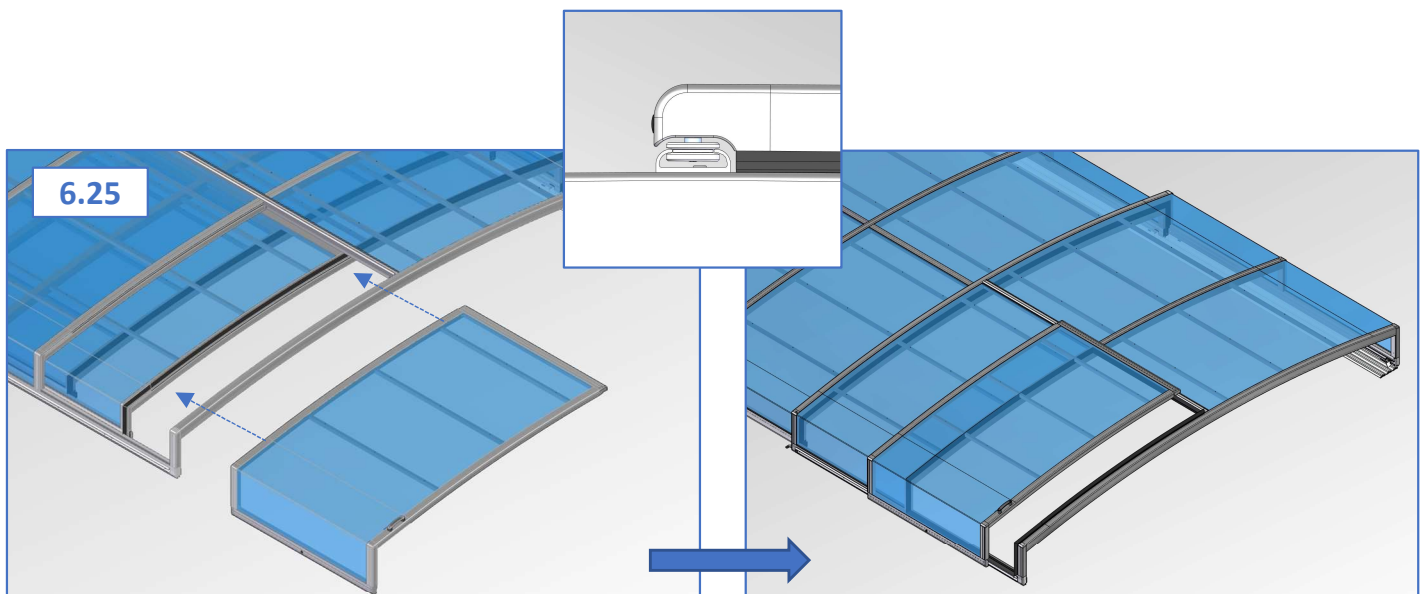
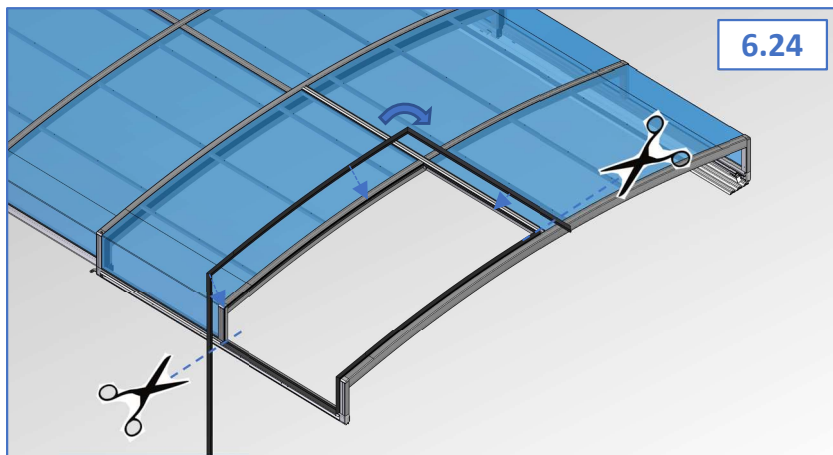
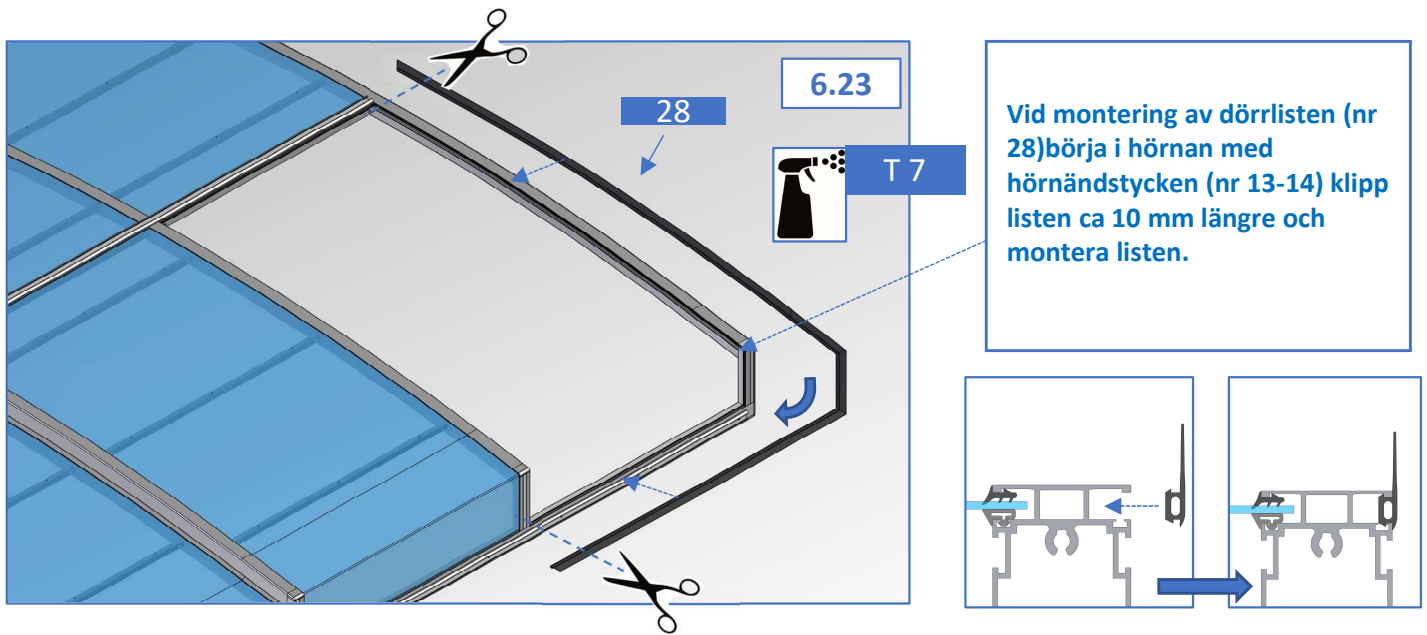

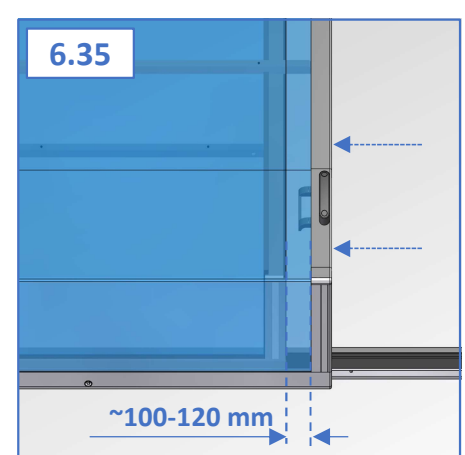
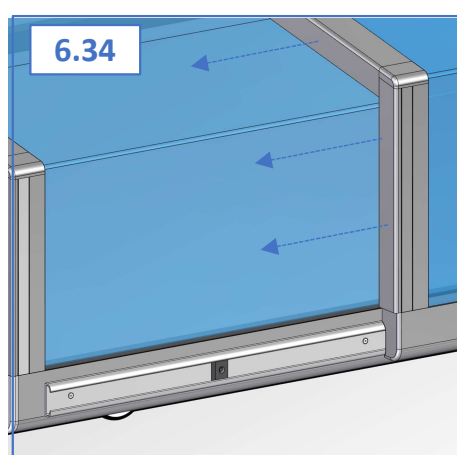
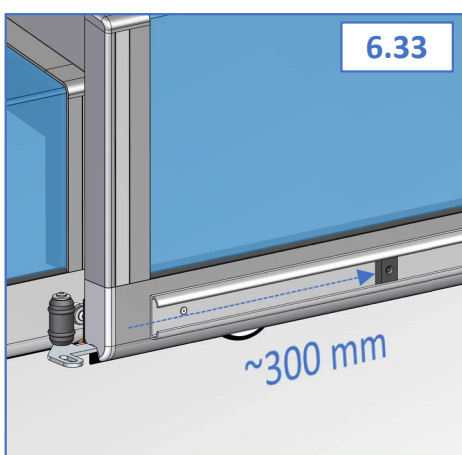
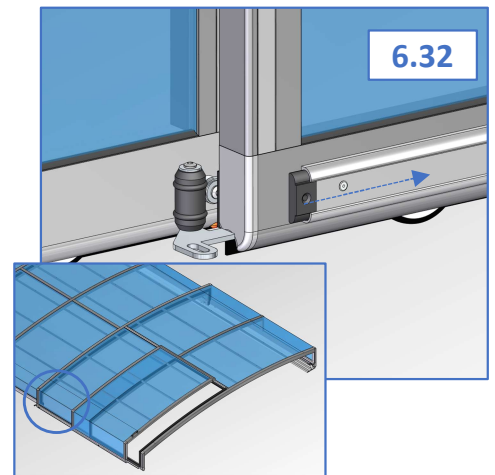
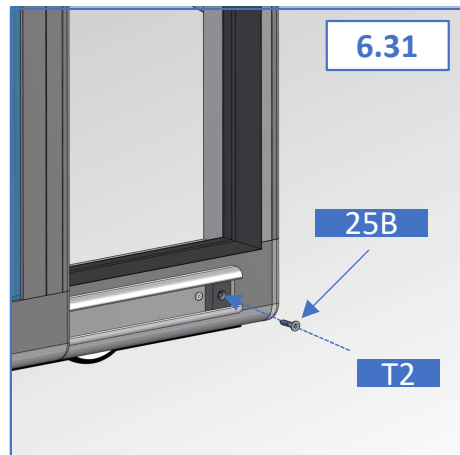
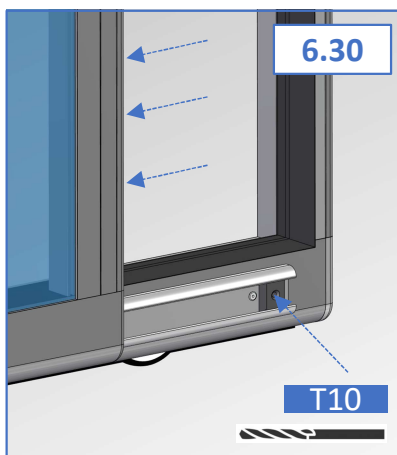
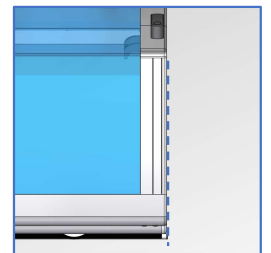
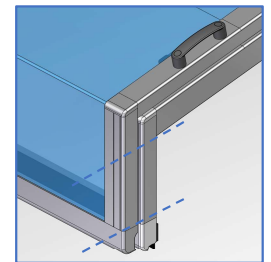
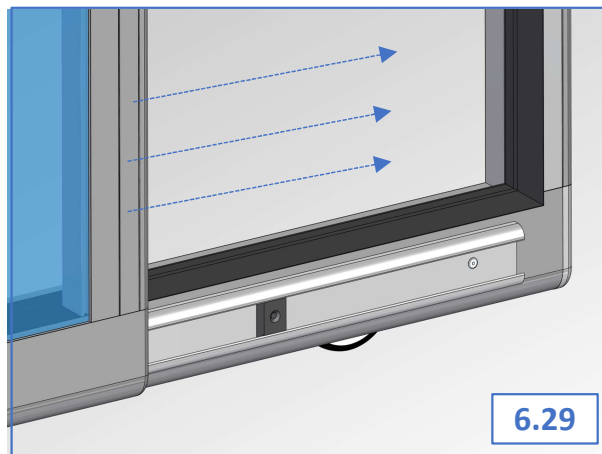
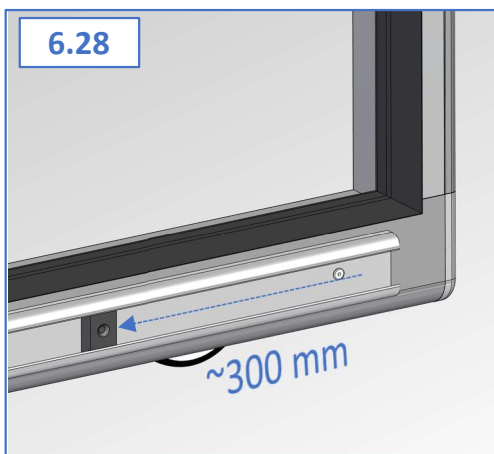
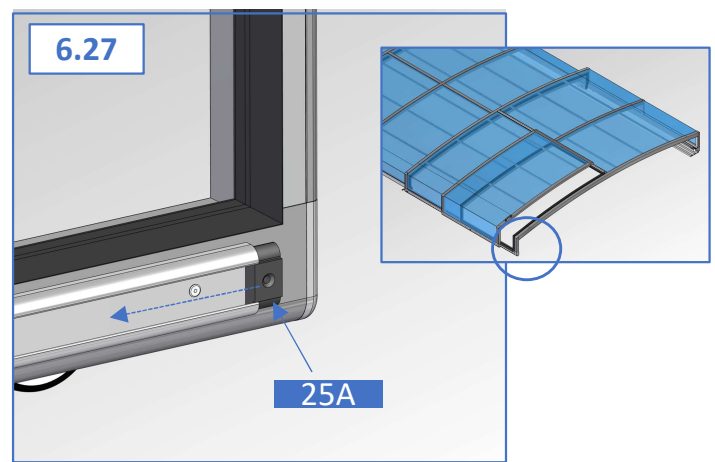
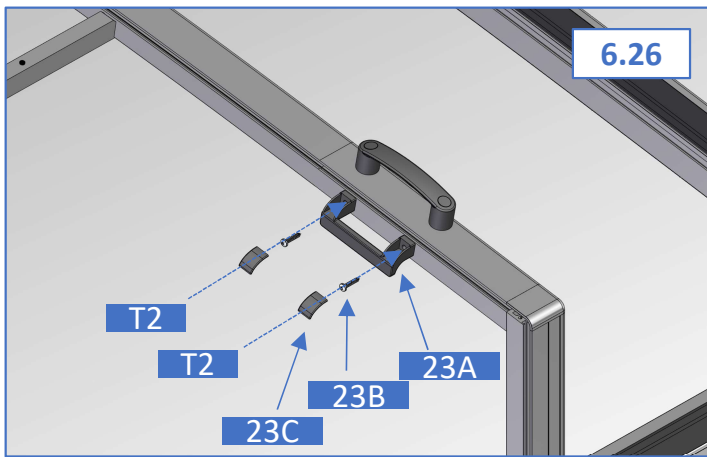



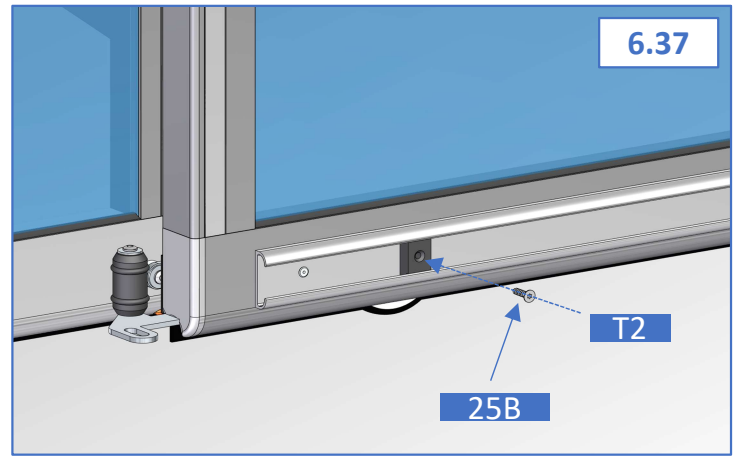
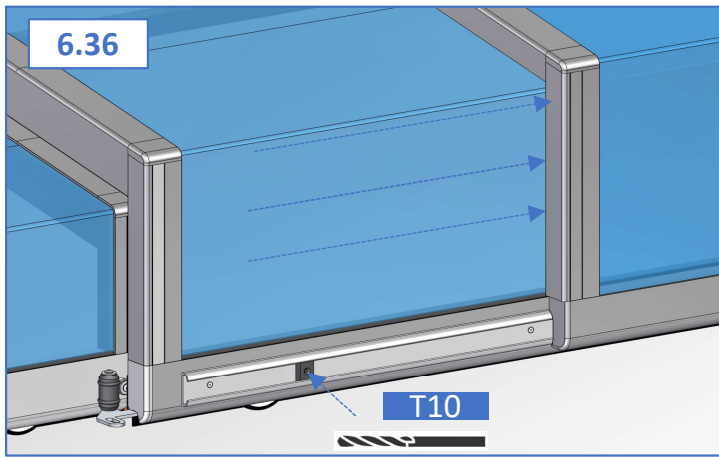

FRONTGAVEL:

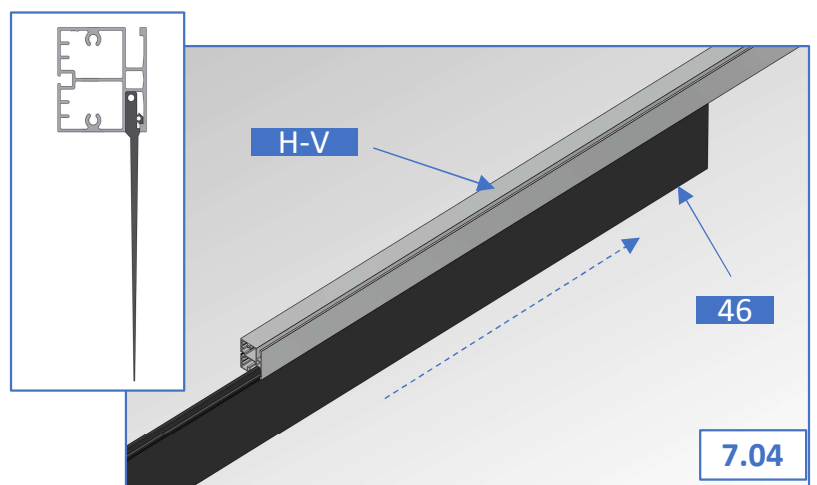
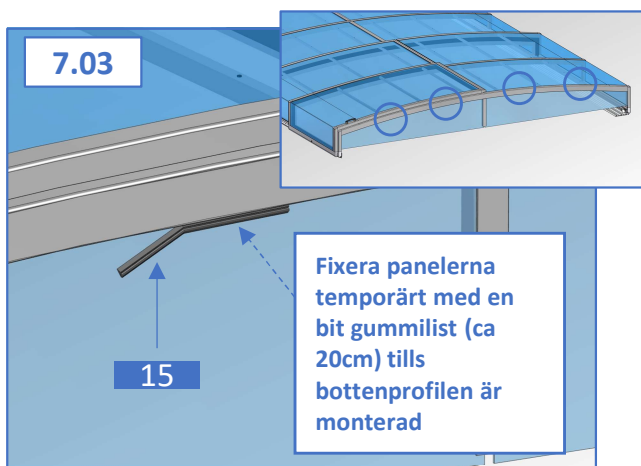
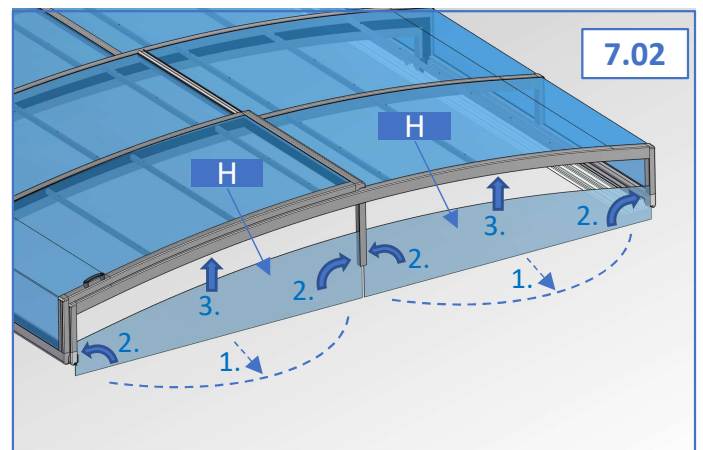
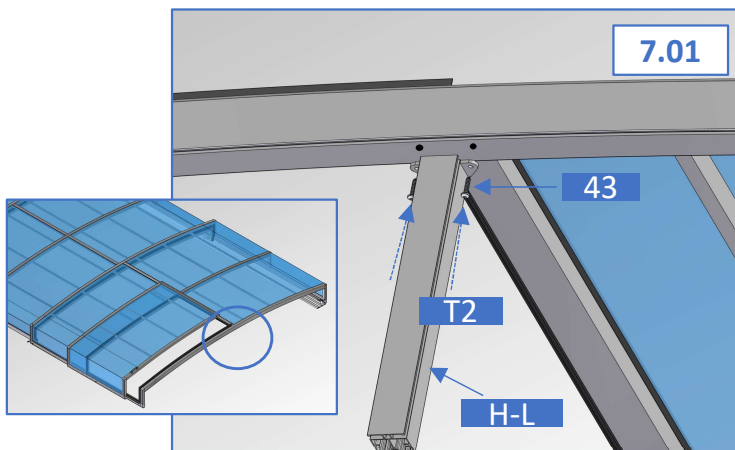

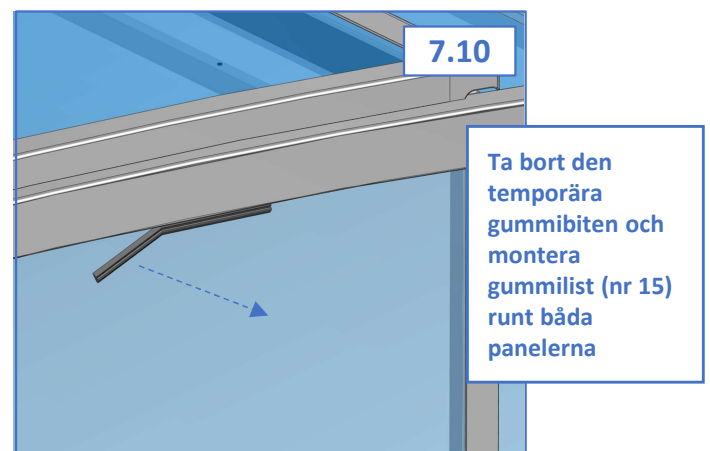
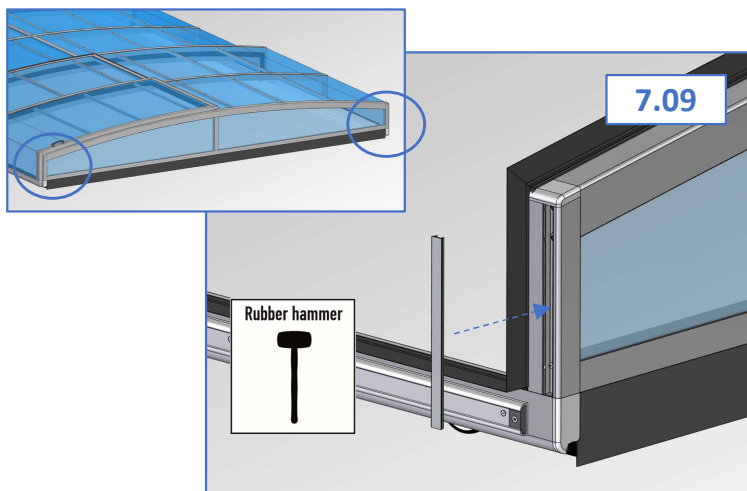
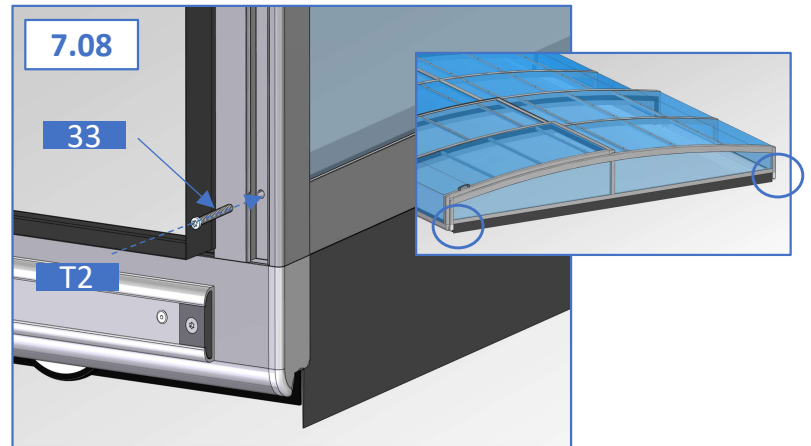
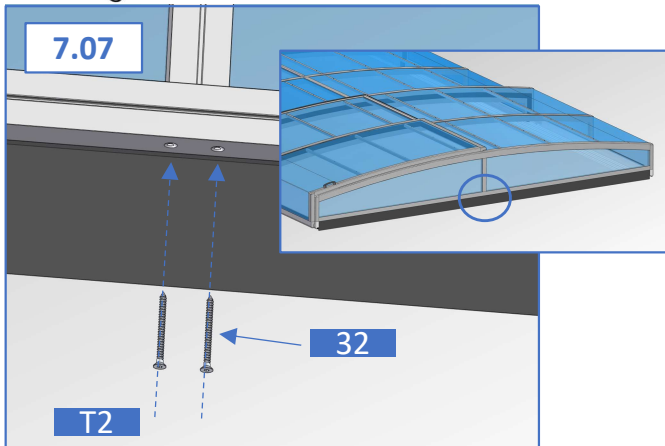
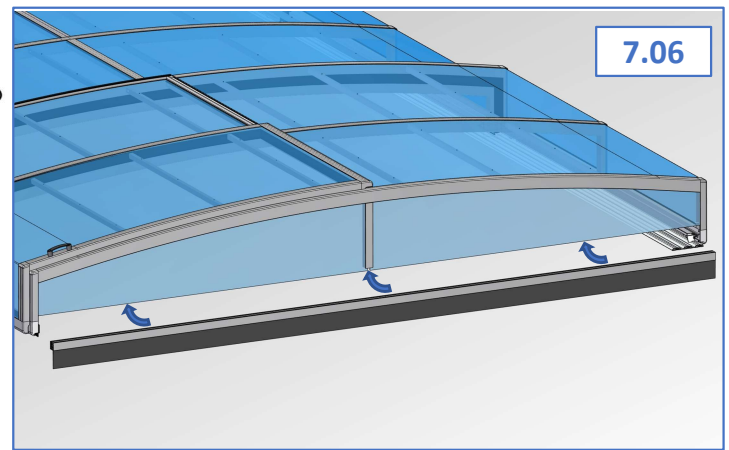
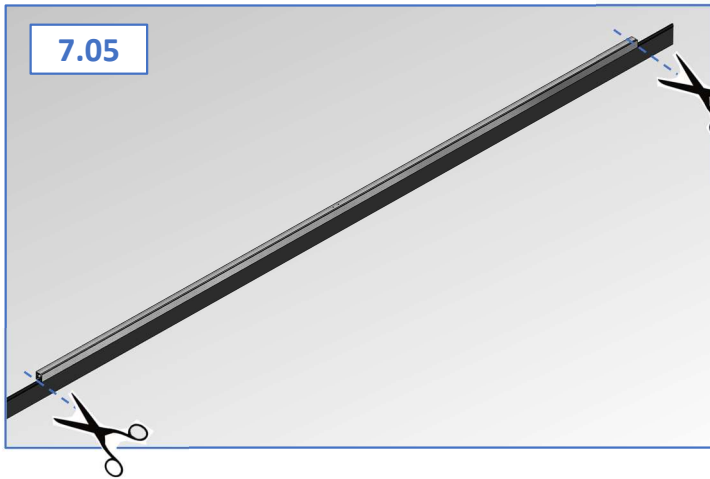

### BAKGAVEL:

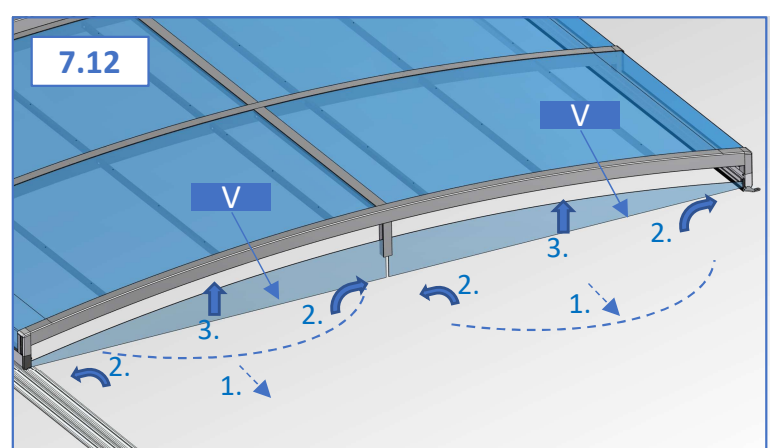
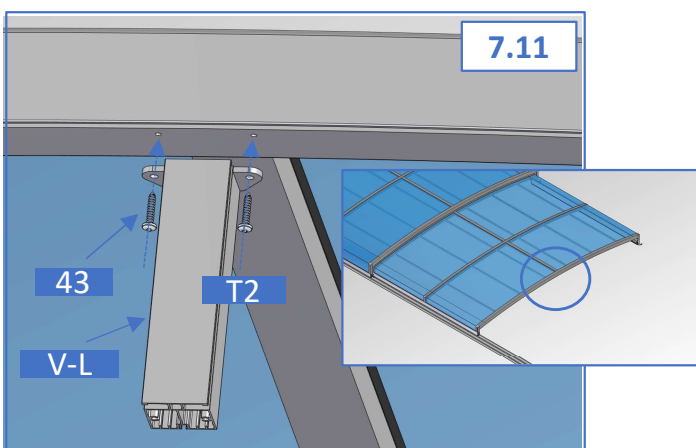

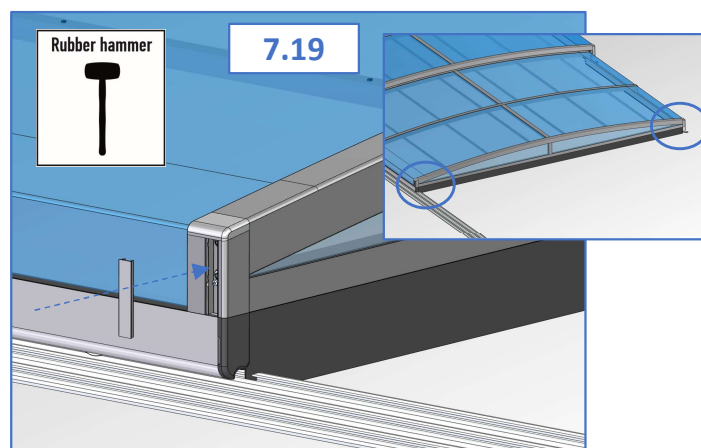
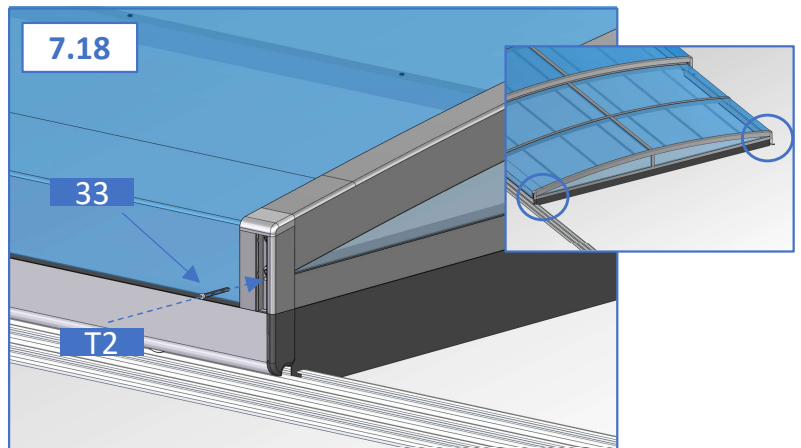
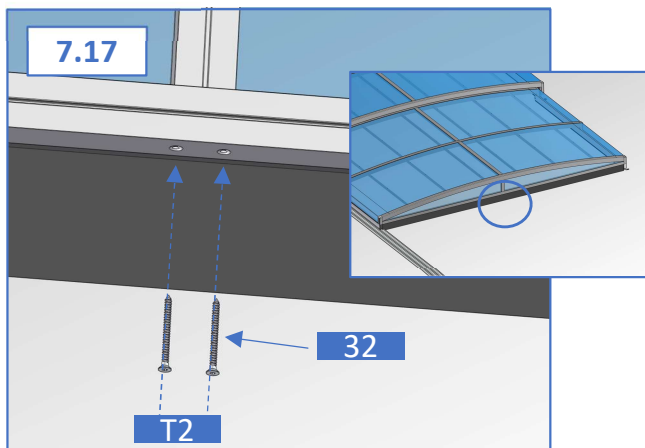
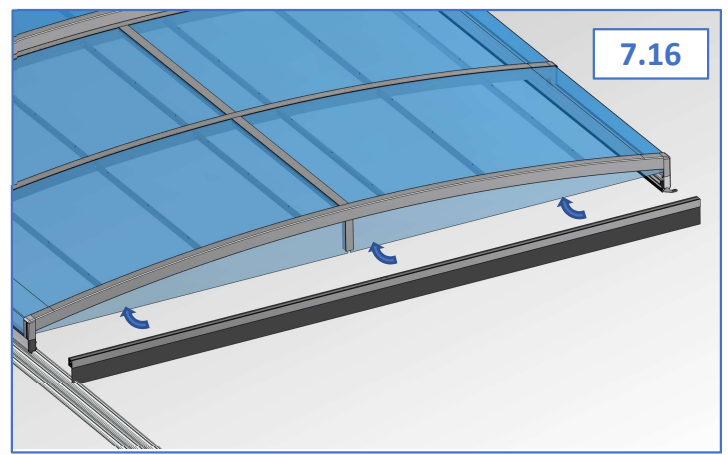
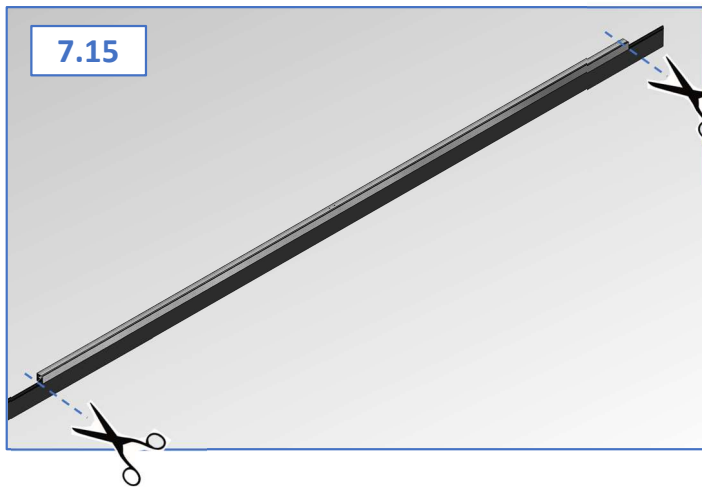
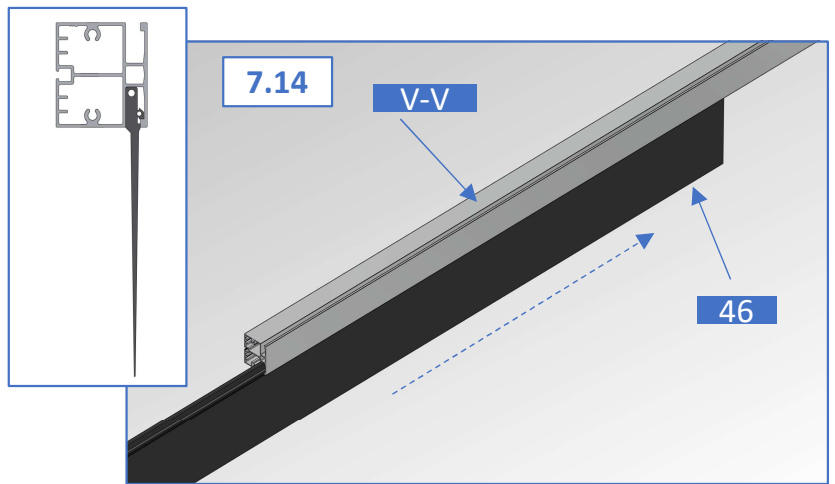
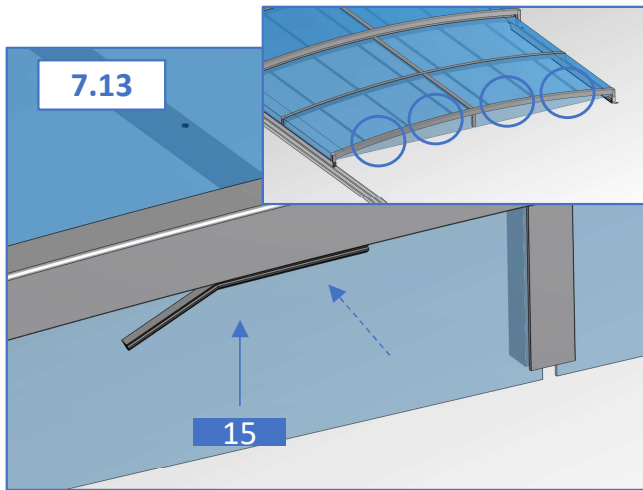



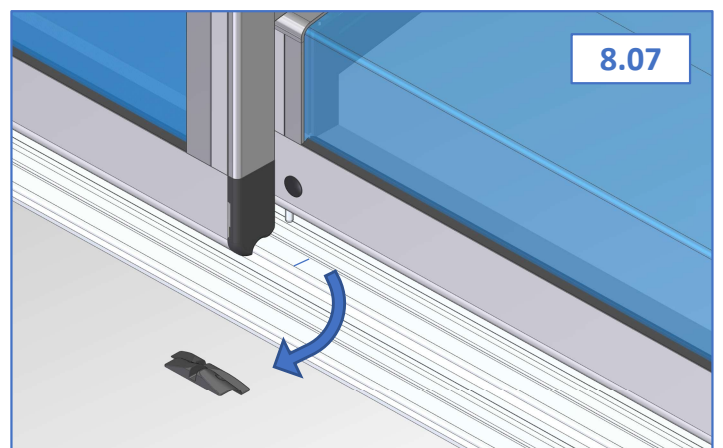
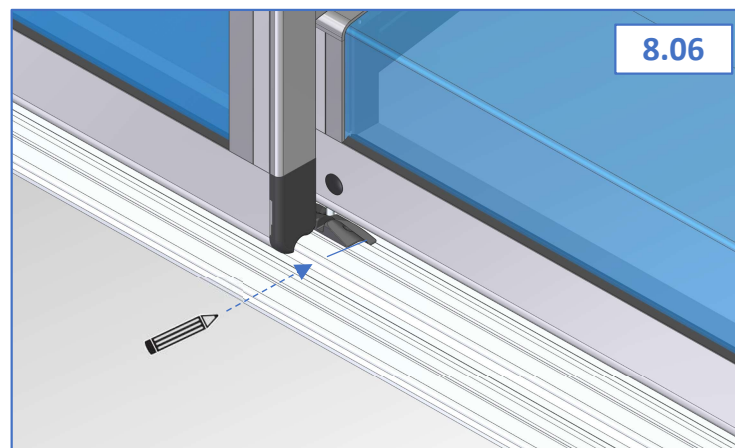
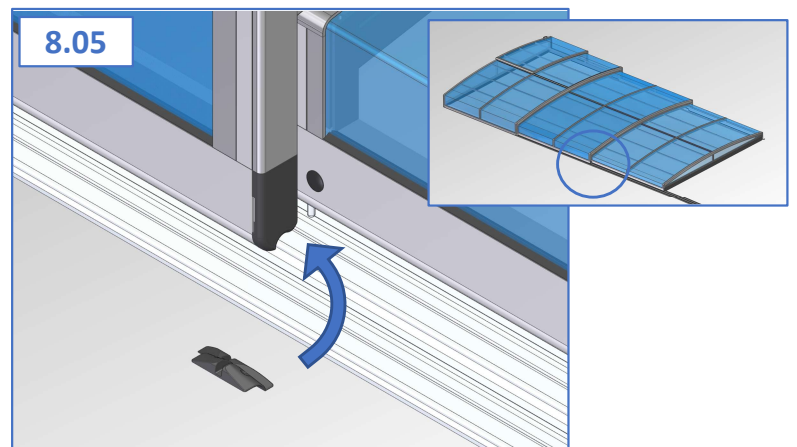
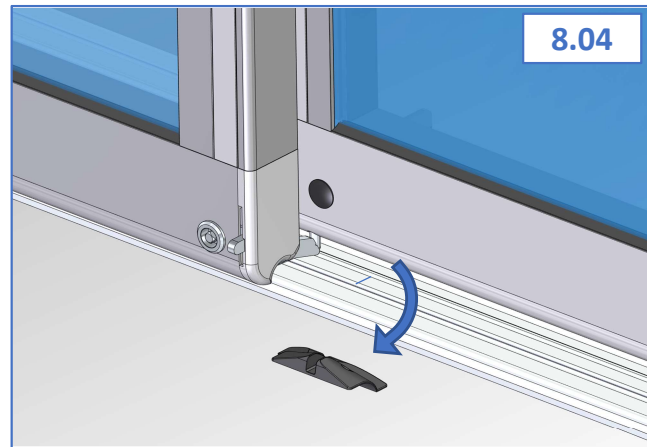
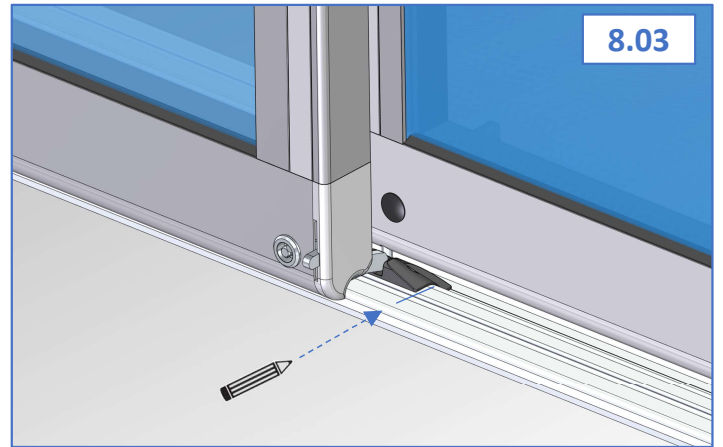
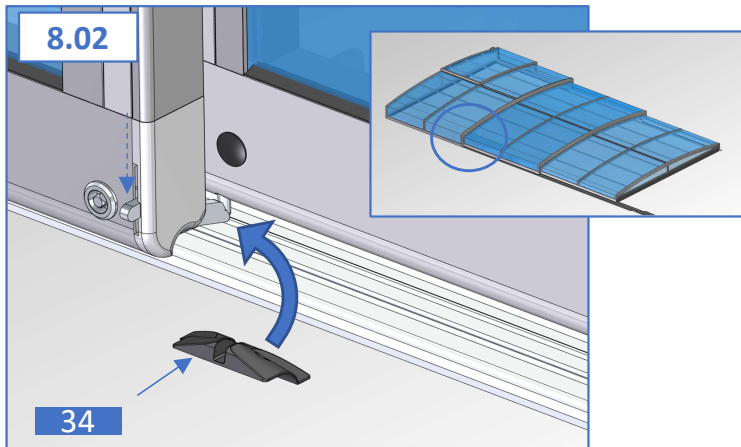
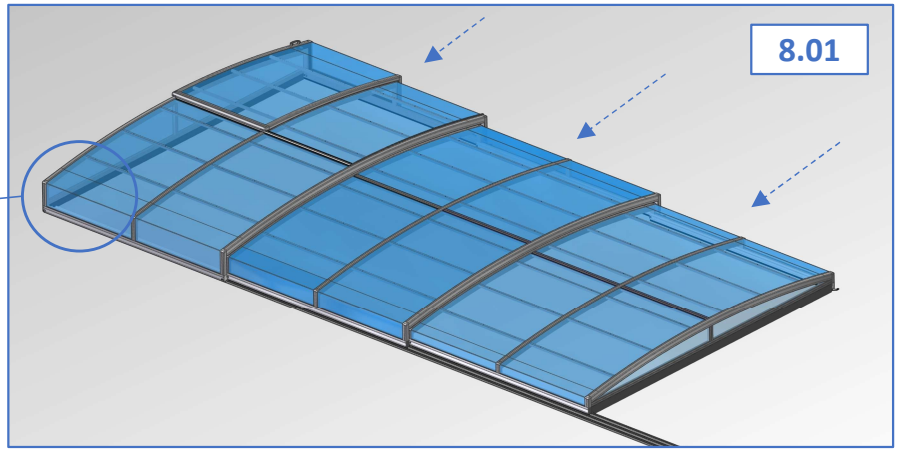
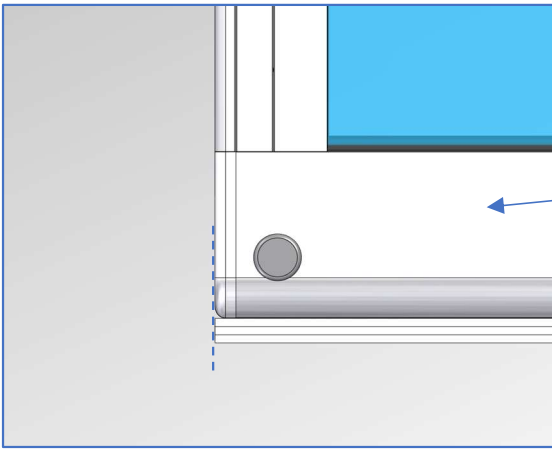



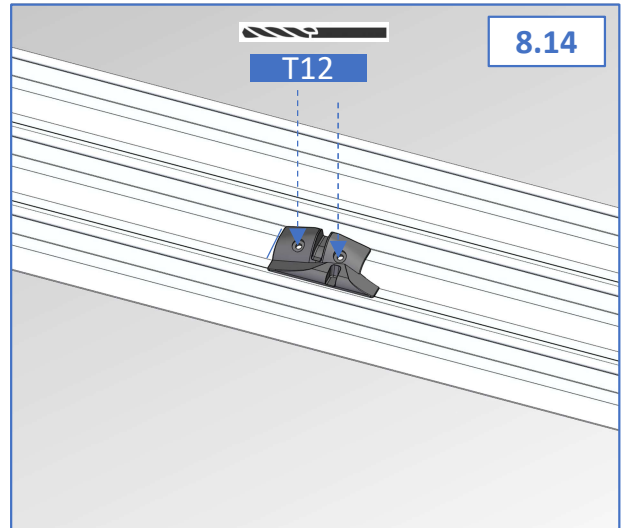
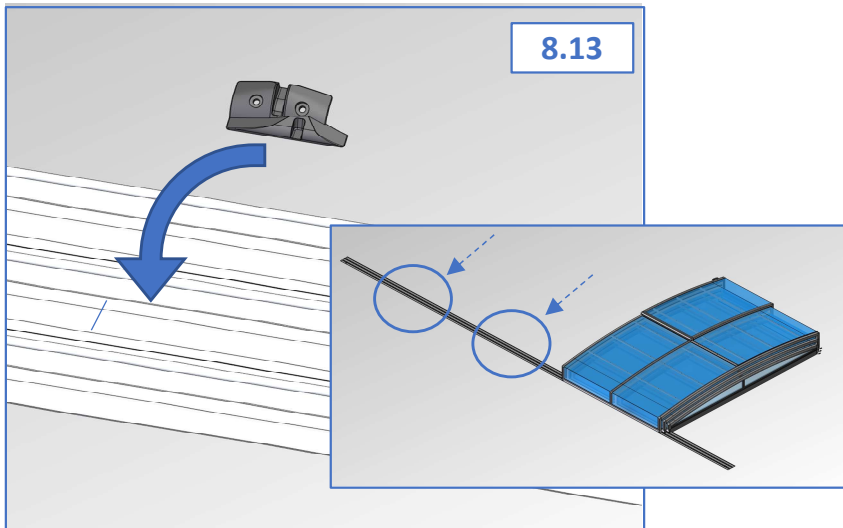
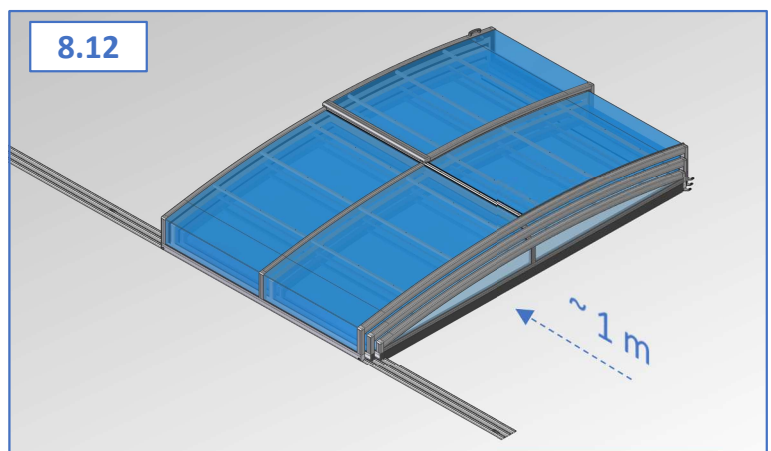
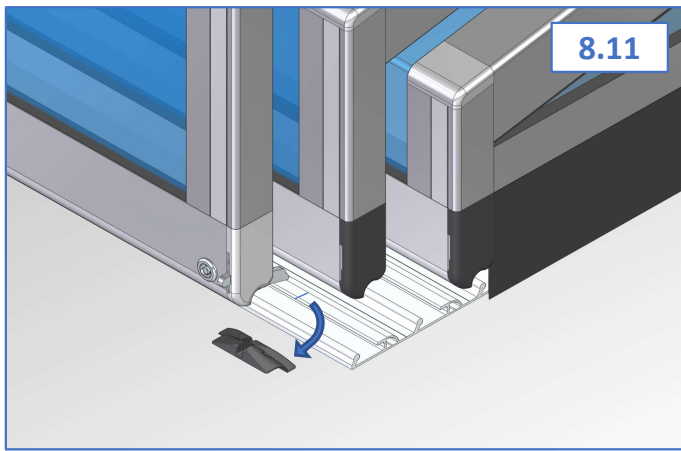
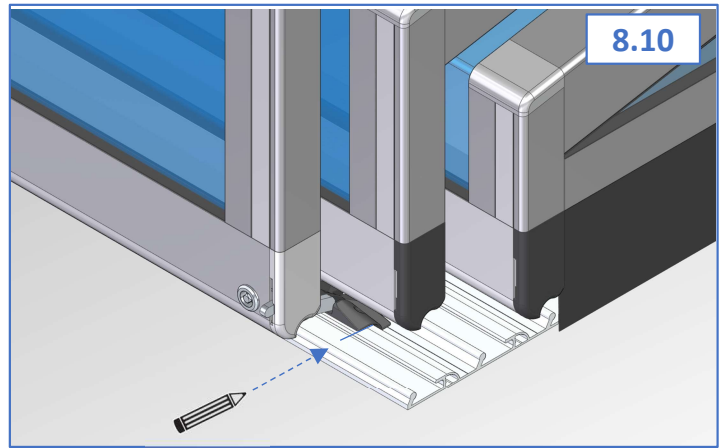
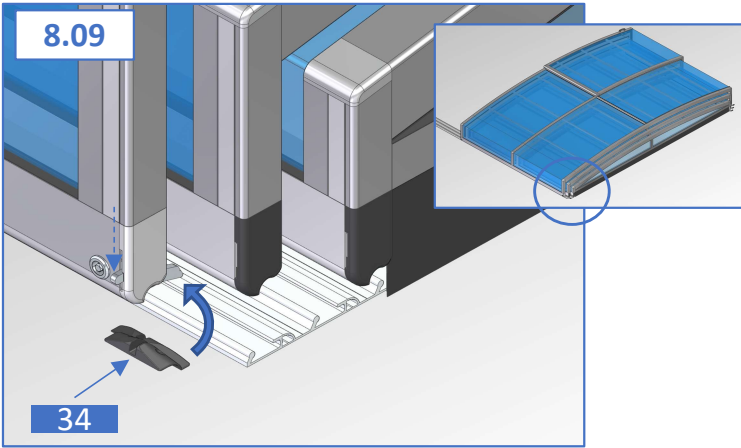
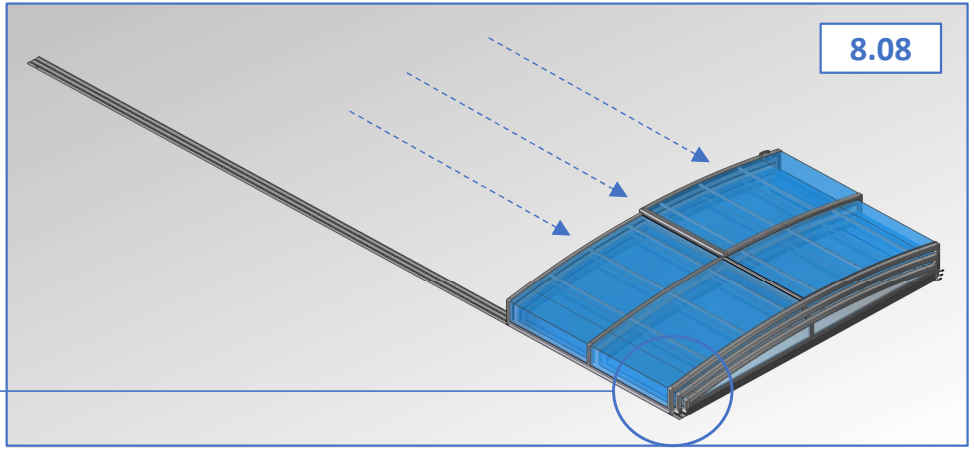
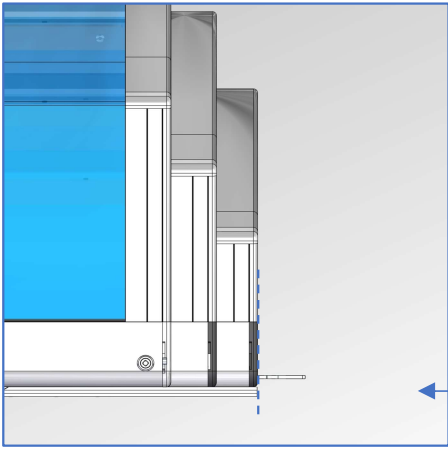

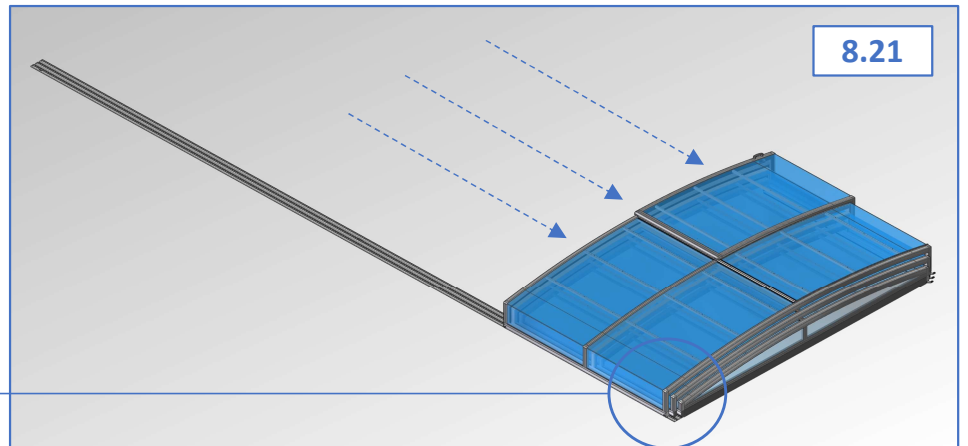
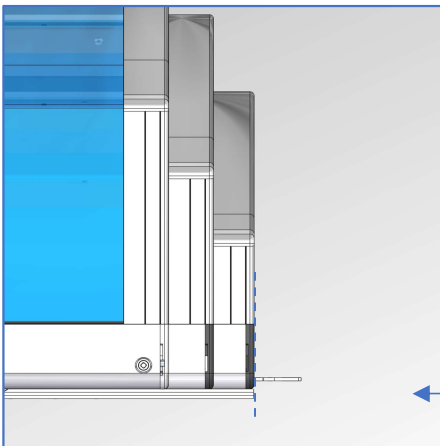
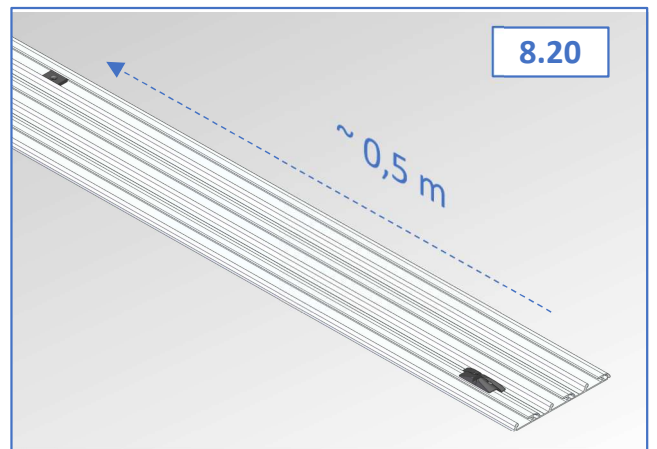
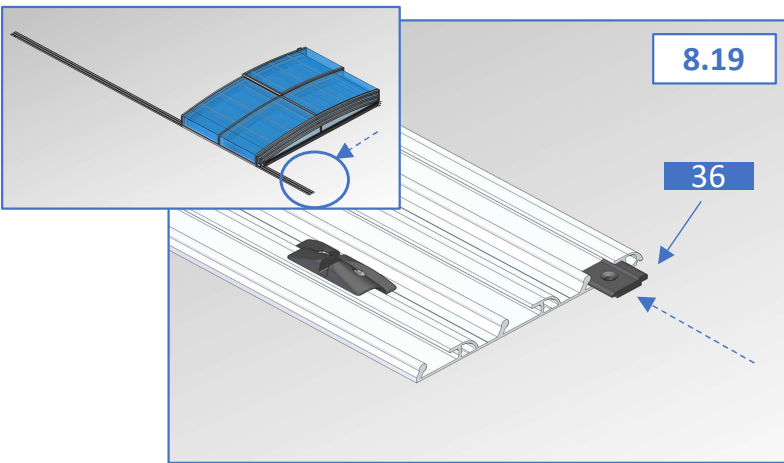
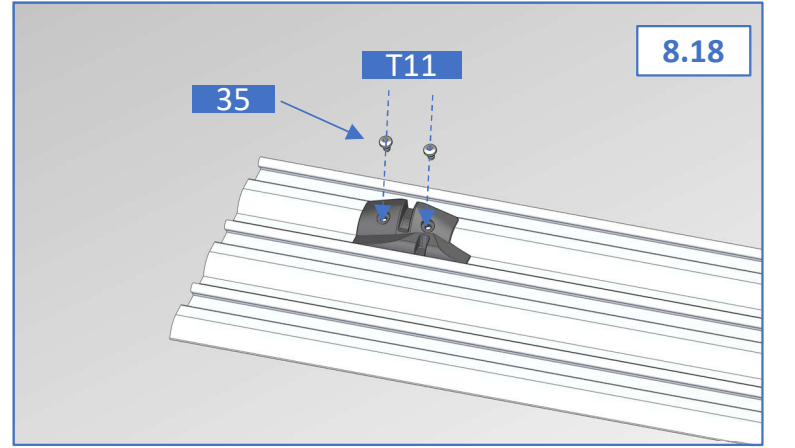
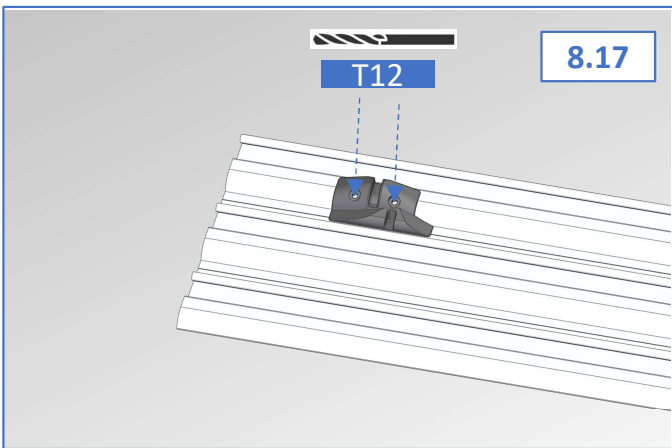
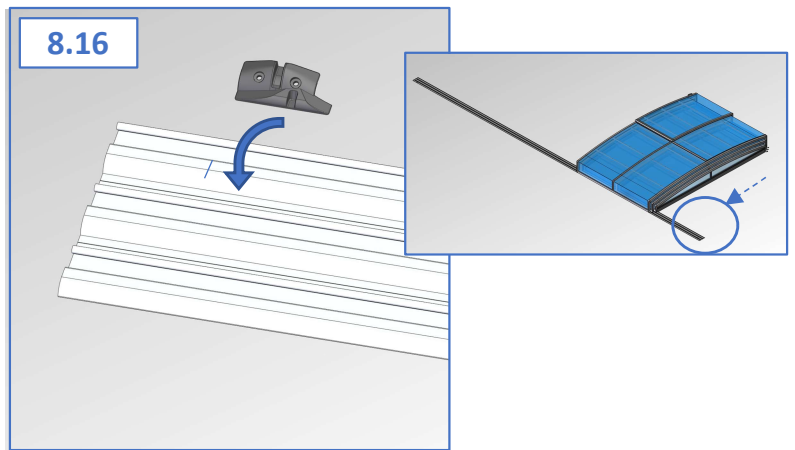
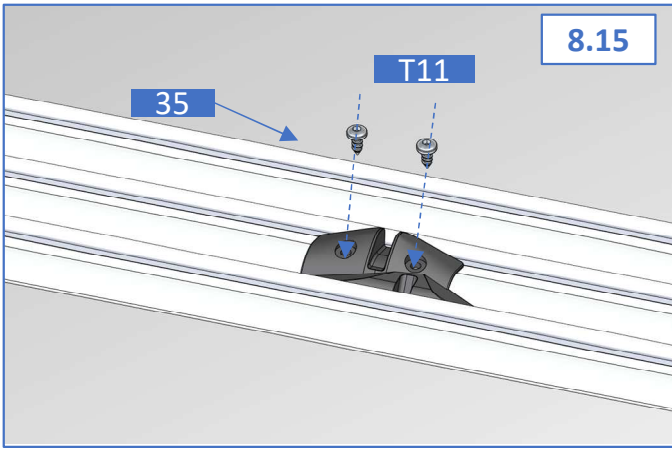

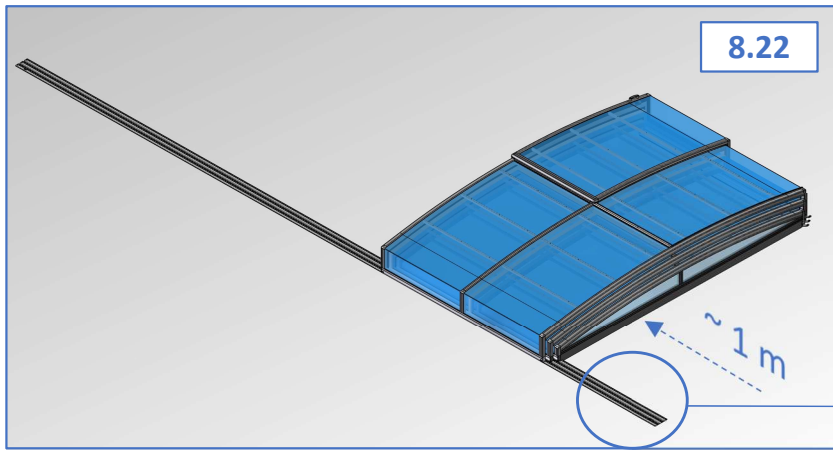

På hårt underlag (ej trä) ska hålen borraras med 6 mm borr och sen 10 mm borr under skenan och minst ett djup på 60 mm

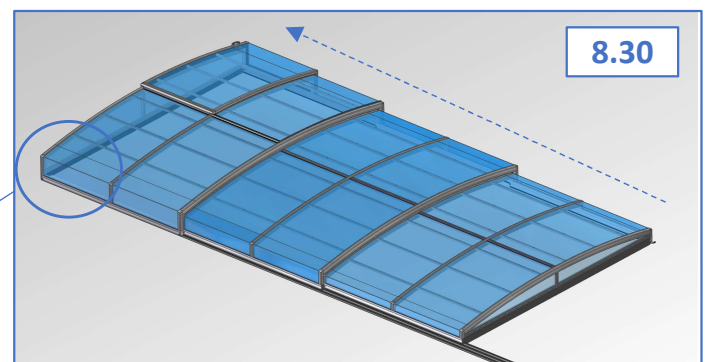
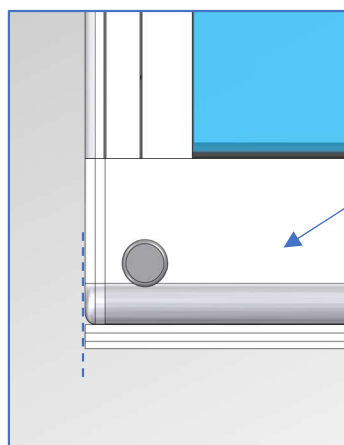
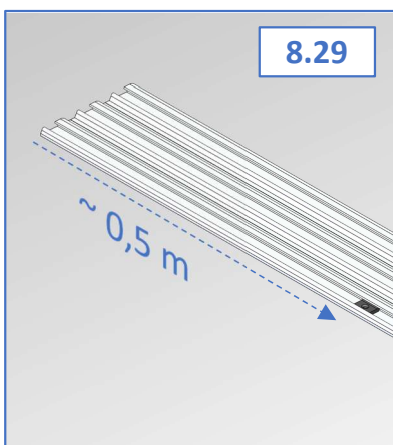
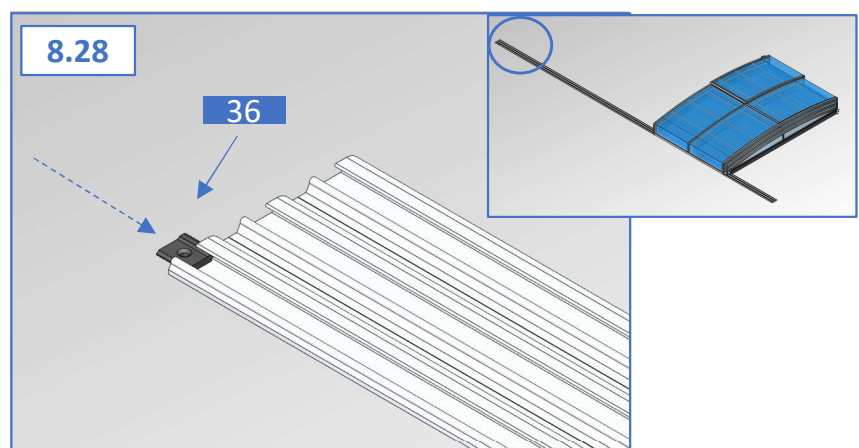
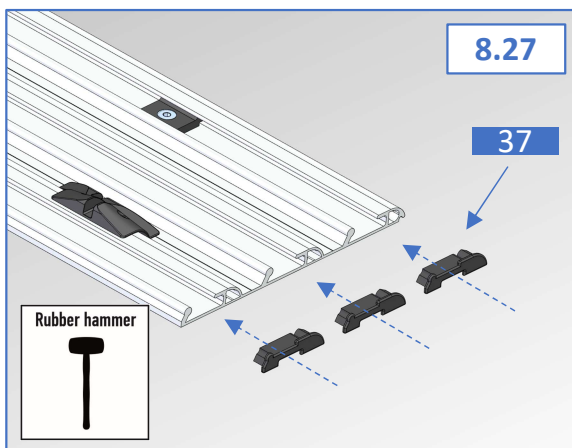
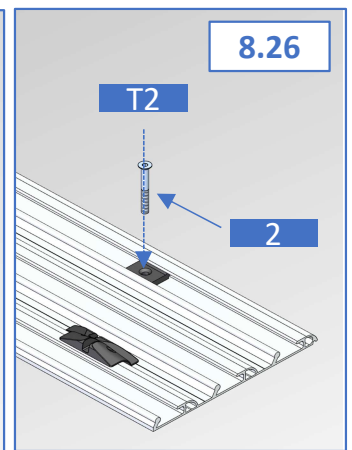
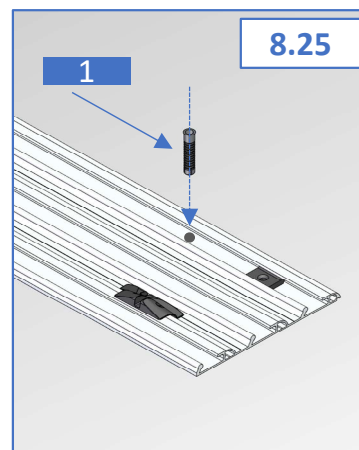
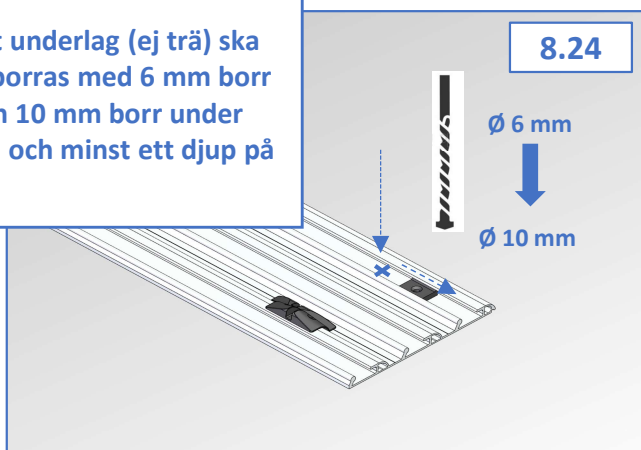



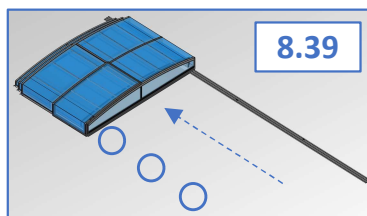
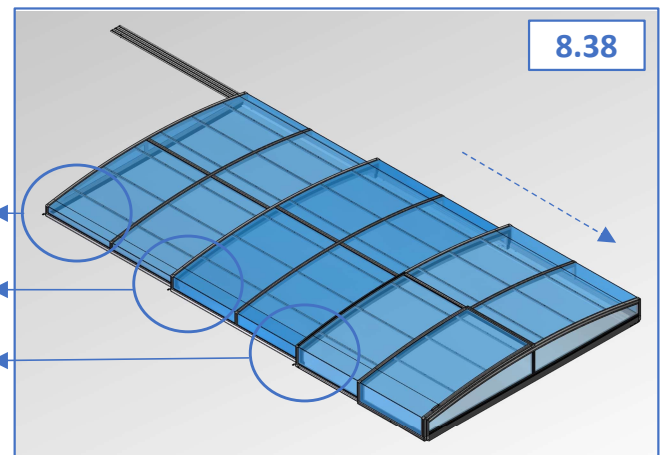
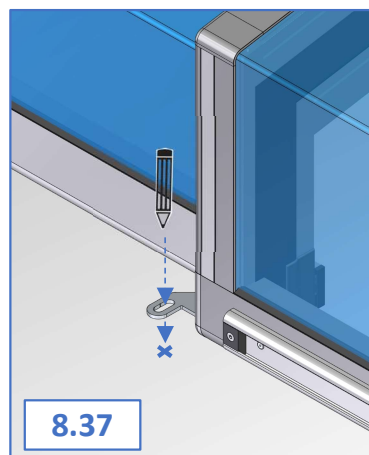
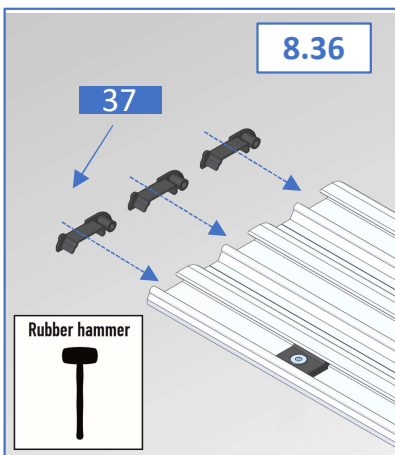
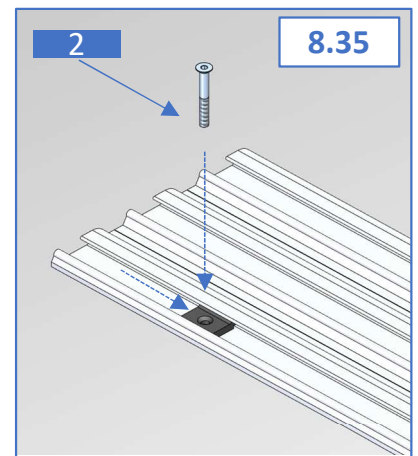
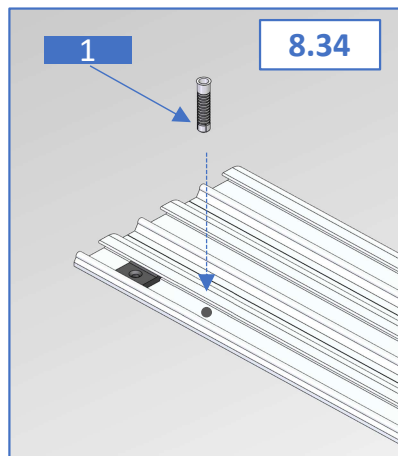
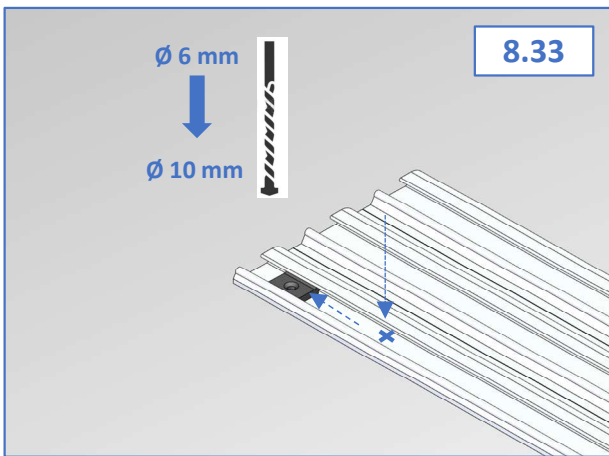
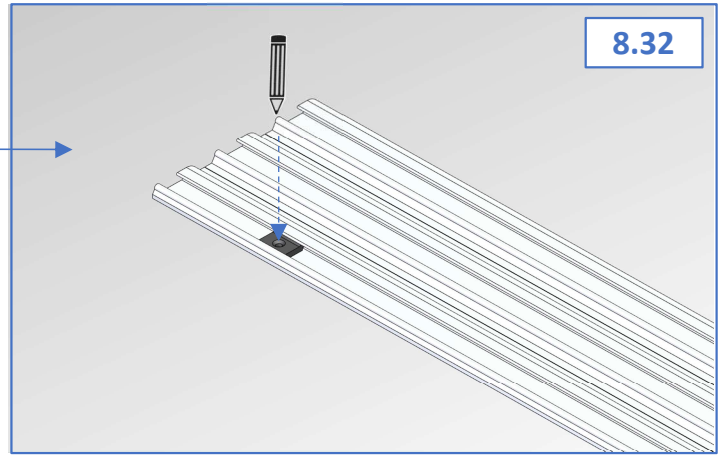
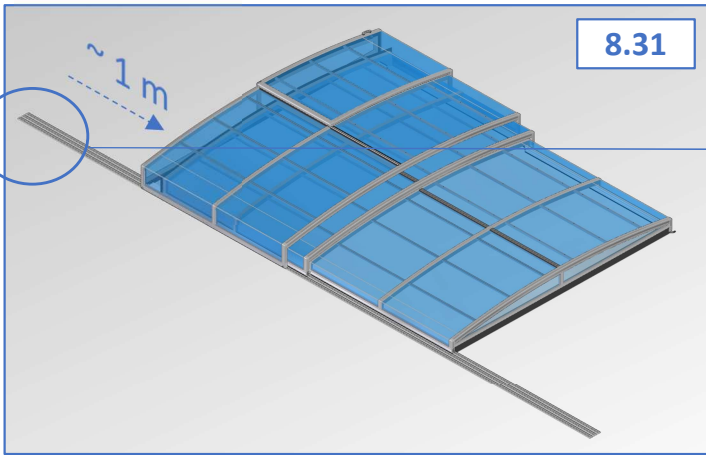

Montering på hårt underlag

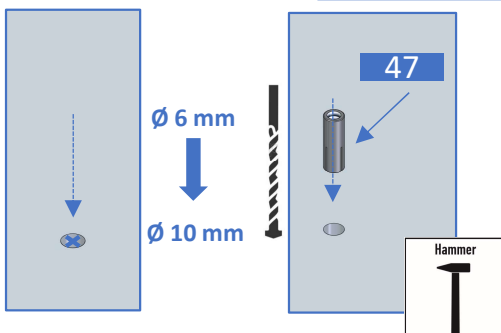

Montering på trä.

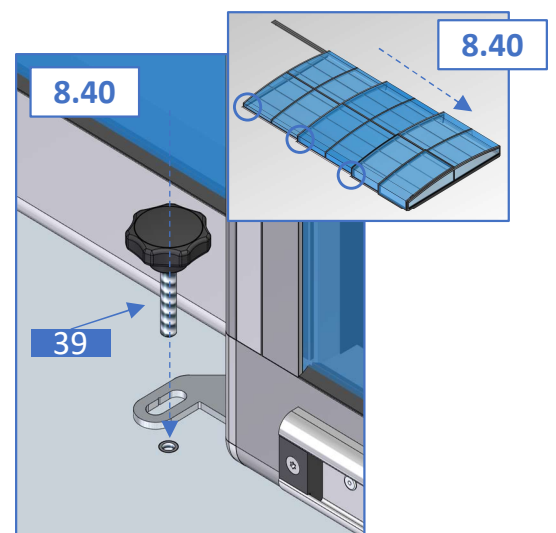
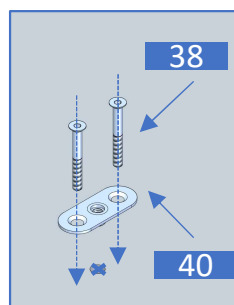



## Garanti och användarmanual för Leia boxtak

För användning av pooltak och säkerställa bästa funktion bör nedan information tas i beaktning.

1. Snöviktt – pooltak är en aluminiumkonstruktion vilket innebär att snövikten är begränsad. Vid kraftigt snöfall måste snön tas bort från pooltaken. Tänk på att blötsnö väger mycket.
2. Vindsäkra – sektionerna måste vara fixerade/låsta antingen helt stängt och ev. vikbar gavel, dörr, fönster och alla öppningsbara detaljer måste vara stängda/låsta.
3. Skenorna måste vara rena från skräp (sand, grus, löv och grenar) före användning.
4. Panelens gummilist kan eventuellt glida ur aluminiumprofilen pga. termisk expansion. Om detta händer så spraya med fönsterputs och tryck tillbaka gummilisten.
5. Panelerna ska endast rengöras med rent vatten. Använd ej högtryckstvätt eller borstar, svampar eller rengöringsmedel med slipmedel.
6. Rörliga delar (lås, fjäder bultar, etc.) bör behandlas med WD 40 minst 2 ggr/år (före och efter säsongen)
7. Pooltaket bör öppnas och stängas sakta och försiktigt, bromsa gärna in vid varje automatisk låsning eftersom delarna är gjorda för att positionera och fixera sektionerna inte bromsa och stoppa sektionerna. Skenlåsen är slitagedelar och kan behövas bytas efter några år. Skador som uppkommit pga. ovarsam hantering omfattas inte av garanti.
8. Kemikalier (felaktiga vattenvärden i poolen, aggressiva rengöringsmedel) kan missfärga fästelement av rostfritt stål (A2, 1.4301). det påverkar inte materialkvaliteten och kan lätt avlägsnas med en mjuk trasa och flytande rengöringsmedel (utan slipmedel).

Skador som uppkommer pga. ovanstående punkter inte efterföljs omfattas inte av garantin.

